

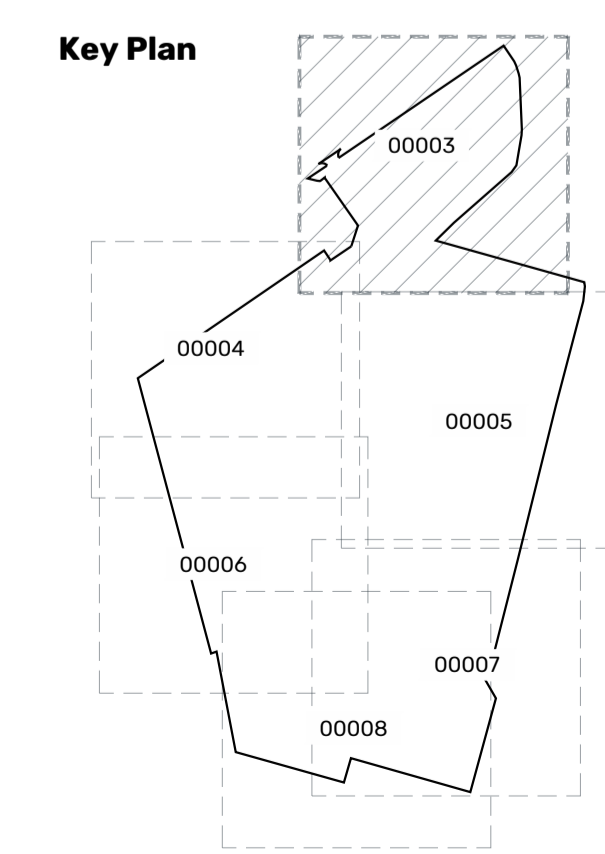

- SF07a Picnic Tables
- SF08 In Ground Trampoline
- SF09 Balance Disk
- SF10 Climbing Frame
- SF11 Nest Swing
- SF12 Spinning Wobble Dish
- SF13 Spinner with Handles
- SF14 Green House
- SF15 Potting Shed
- SF16 Sports Equipment Storage Cabinet
- SF17 Slide
- SF18 Chicken Coop
- SF19 Farm Storage
- SF20 Weatherproof Canopy
- SF21 Tensile Canopy
- SF22 Straight Timber Benches
- SF23 Curved Bench
- SF24 Caretakers Storage
- SF25 Balance Beam
- SF26 Log Tunnel
- SF27 Play Log
- SF28 Log Seats
- SF29 Embankment Climber
- SF30 Fire Pit
- SF31 Fire Cooking Bowl
- SF32 Mud Kitchen
- SF33 Composter
- SF34 Habitat Feature
- SF35 Play Boulders
- SF36 Water Feature
- SF37 External Play Storage
- SF38 Bird Box
- SF39 Bat Box
- SF40 Outdoor Water Point
- SF41 Entrance Sign
- Existing Trees & Vegetation Retained
- Existing Trees & Vegetation Removed
- Proposed Tree Planting
- Native Hedge Planting
- Ornamental Planting
- Woodland Buffer Planting
- Reinforced Grass Planting
- Meadow Planting
- Amenity Grass
- Existing Grass Retained

©One-Environments Ltd. This drawing is not to be scaled. All dimensions to be verified on site prior to commencement of works. Discrepancies, ambiguities and/or omissions between this drawing & information supplied by others must be reported immediately for clarification before proceeding

- NOTES
- LEGEND
- S01 Asphalt Concrete [Vehicular Grade]
 - S02 Asphalt Concrete [Pedestrian Grade]
 - S03 PCC Concrete Block Paving Type 1 [Car Parking]
 - S04 Resin Bound Paving
 - S05 PCC Concrete Block Paving Type 2
 - S06 PCC Concrete Block Paving Type 3
 - S07 PCC Concrete Sett Paving
 - S08 Reinforced Grasscrete System with Meadow Infill
 - S09 Coloured Asphalt Concrete [Pedestrian Grade]
 - S10 Wetpour Safety Surfacing
 - S11 Self Binding Gravel
 - S12 Recycled bonded rubber mulch
 - S13 Existing Surfacing Retained
 - S13a Existing Tarmac Resurfaced - MUGAs
 - S14 Hazard Warning Paving
 - S14a Tactile Blister Paving
 - S15 Concrete Hardstanding
 - F01 2.4m Secure Weldmesh Fencing with 4.6m ball stop netting (with matching lockable gates where indicated)
 - F02 2.4m Secure Weldmesh Fencing (with matching lockable gates where indicated)
 - F03 1.8m Weldmesh Fencing (with matching lockable gates where indicated)
 - F04 1.2m Weldmesh Fencing (with matching lockable gates where indicated)
 - F05 2.4m Closeboard Timber Fencing - Bin Store (with matching manually operated gates where indicated)
 - F06 3.0m Closeboard Timber Fencing - Sprinkler Tank (with matching manually operated gates where indicated)
 - F07 450mm Steel Kneerail
 - F08 Handrails
 - SF41 Covered Cycle Parking
 - SF42 Cycle stands
 - SF43 EV charging Bays [Active]
 - SF44 Accessible Parking Bay marker Post
 - SF45 External Door Protection
 - SF46 Timber Raised Planter Bed



REVISION P02	DATE 30.01.25	BY RC	CHECKED -
Updated following RDD comments			
REVISION P01	DATE 04.12.25	BY RC	CHECKED -
First Issue			
CLIENT	Kier Construction		
PROJECT	Woodley School and College		
TITLE	Proposed Landscape Plan Sheet 1 of 6		
DWG No.	NWSC-ONE-ZZ-ZZ-D-L-00003	REV	P02
STATUS	PRELIMINARY		
SCALE	1:200	@ A1	DATE 04.12.25 DRN BY RC

