

Sheffield Cycle Stand

BXMW/GS/SHEFFIELD-STAND

broxap[®]
street furniture



This best-selling tubular cycle stand allows a bike to be secured in a variety of ways.

Features:

- Sold Secure Certified & Secured By Design Accredited
- Wide range of standard RAL/BS colour options
- Optional PROTEX™ finish with nano-powder coating for superior corrosion protection and longer lifespan
- Contributes to ENE8 credits, supporting environmentally certified developments and planning goals
- Recommended by the National Cycling Association
- Available root fixed or base plated



☎ 01782 564411
✉ info@broxap.com
🌐 www.broxap.com

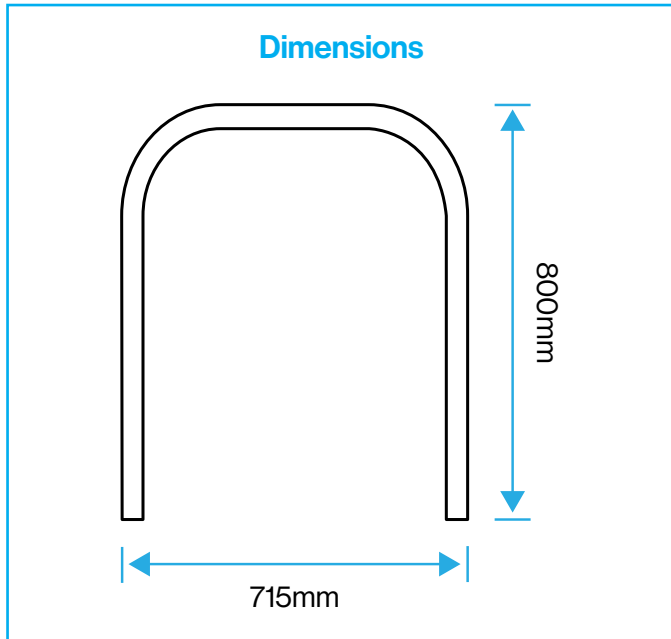

Product Details

Product Name	Sheffield Cycle Stand
Product Code	BXMW/GS/SHEFFIELD-STAND
Dimensions	715 x 800 mm
Capacity	2 cycles per stand
Material	Galvanised steel
Certifications	Sold Secure Bronze Certified Secured By Design Accredited
Options	Polyester powder coated in any standard RAL/BS colour Sold Secure Silver Certified 600mm junior height Grade 304/316 stainless steel Polyurethane (PU)
Fixing	Root fixed or base plated

