

01  
03004 B1a/b - Proposed Low Seating Walls  
Scale 1: 20 @A1

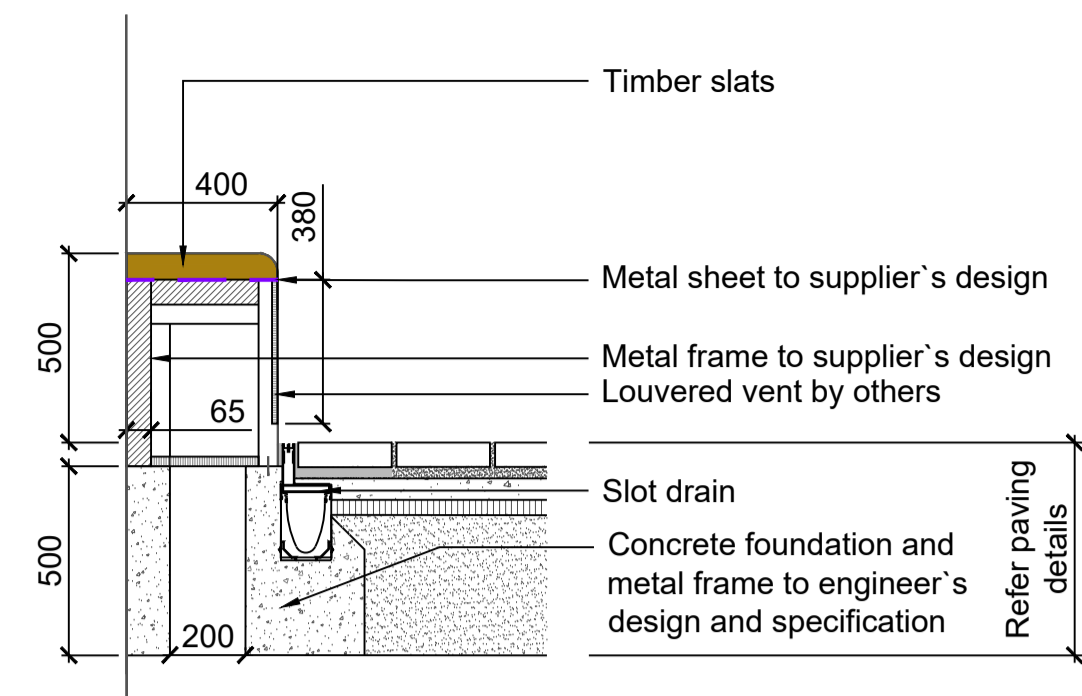

04  
03004 B3b - Proposed Low Seating Walls with Timber Slat & Louvered Panels  
Scale 1: 20 @A1

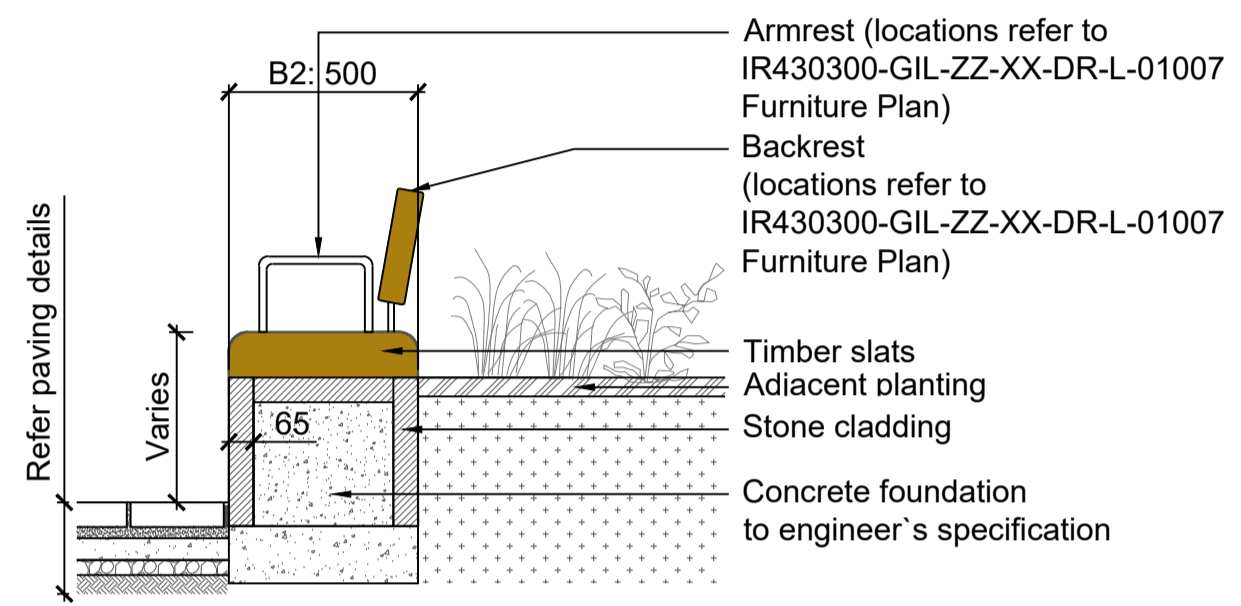

02  
03004 B2a/b - Proposed Low Seating Walls with Timber Slats Seating  
Scale 1: 20 @A1

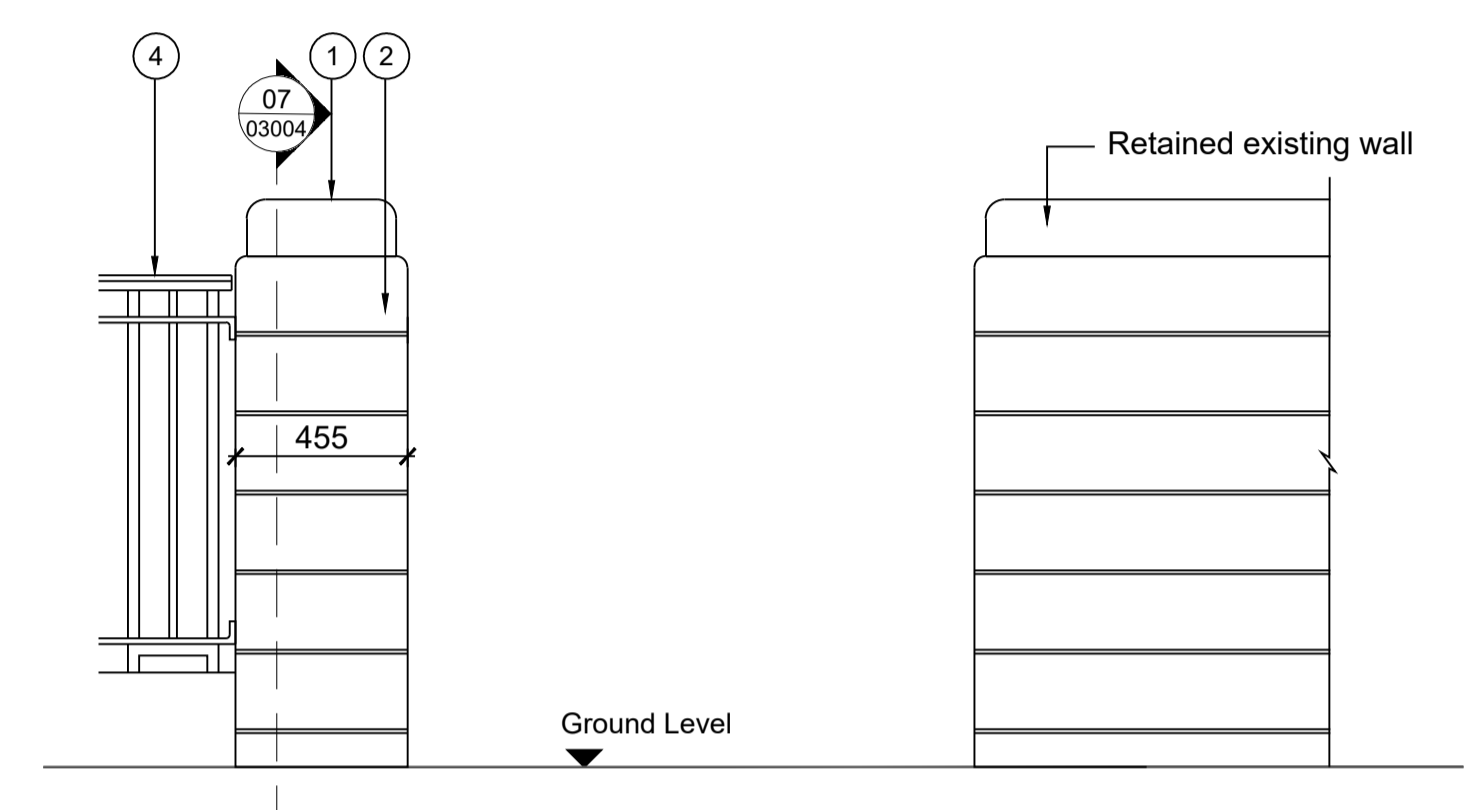

05  
03004 W1a - Replicated Square Pier Elevation  
Scale 1: 20 @A1

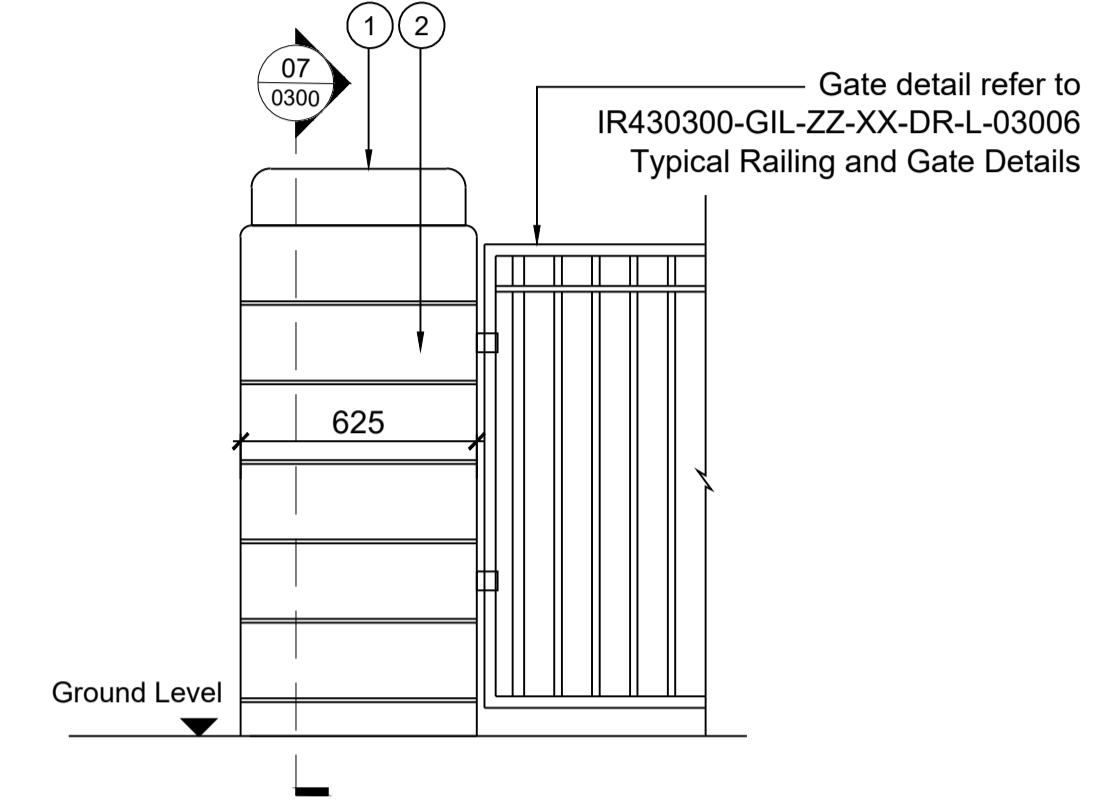

06  
03004 W1b - Replicated Rectangular Pier Elevation  
Scale 1: 20 @A1

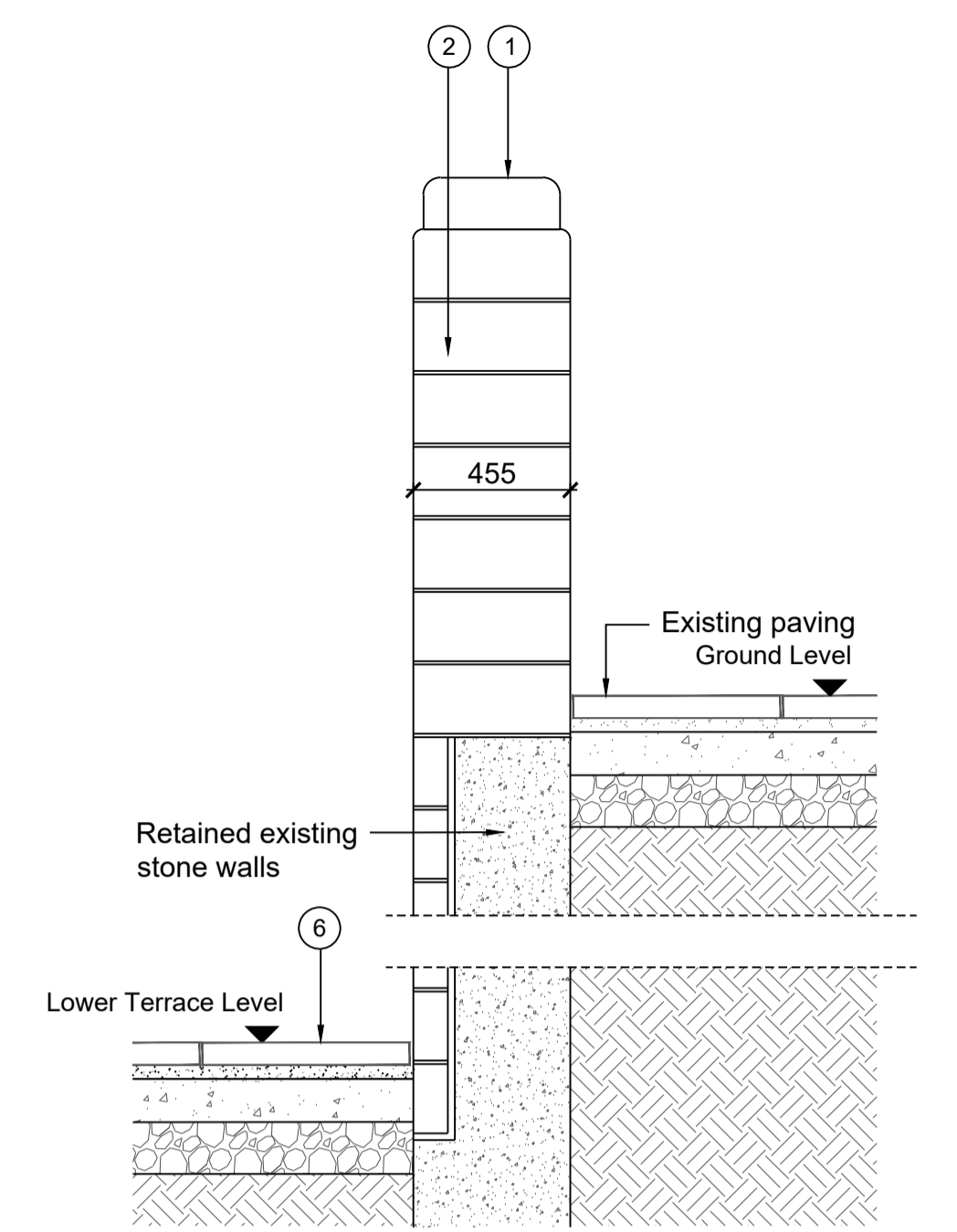

07  
03004 W1a/b - Replicated Square Pier Section  
Scale 1: 20 @A1

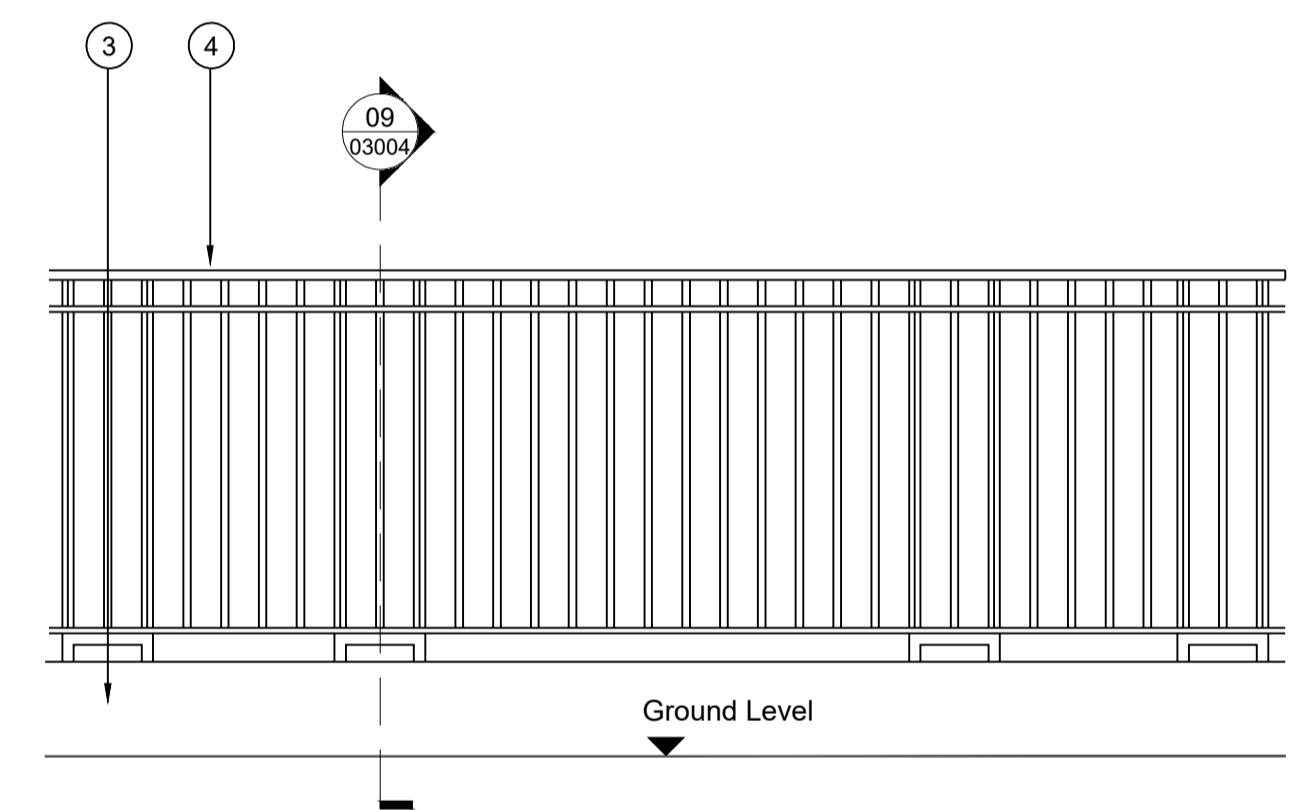

08  
03004 W2a - Proposed Retaining Walls with 1.1m High Balustrade and Metal Cladding Elevation  
Scale 1: 20 @A1

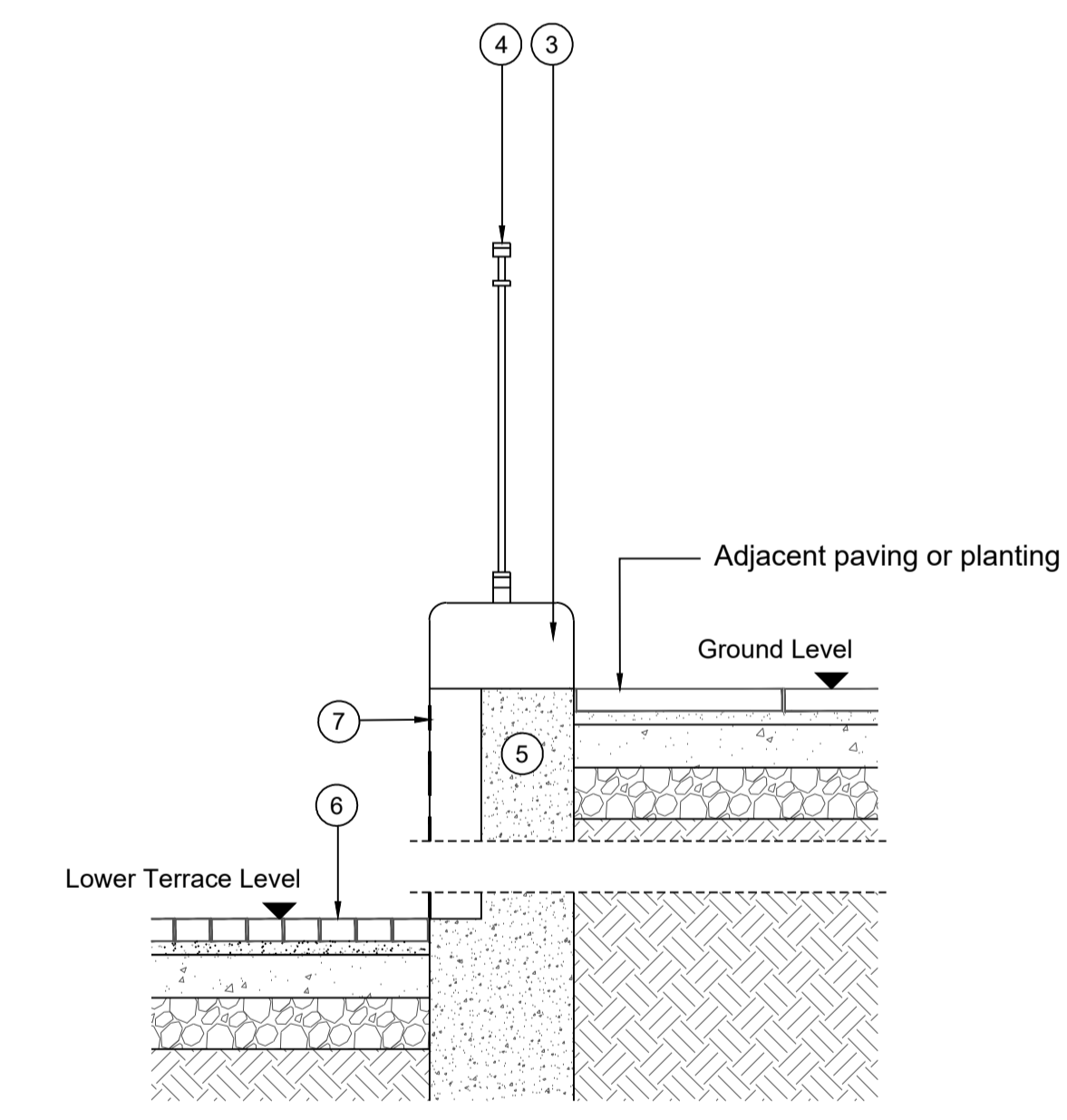

09  
03004 W2a - Balustrade Section  
Scale 1: 20 @A1

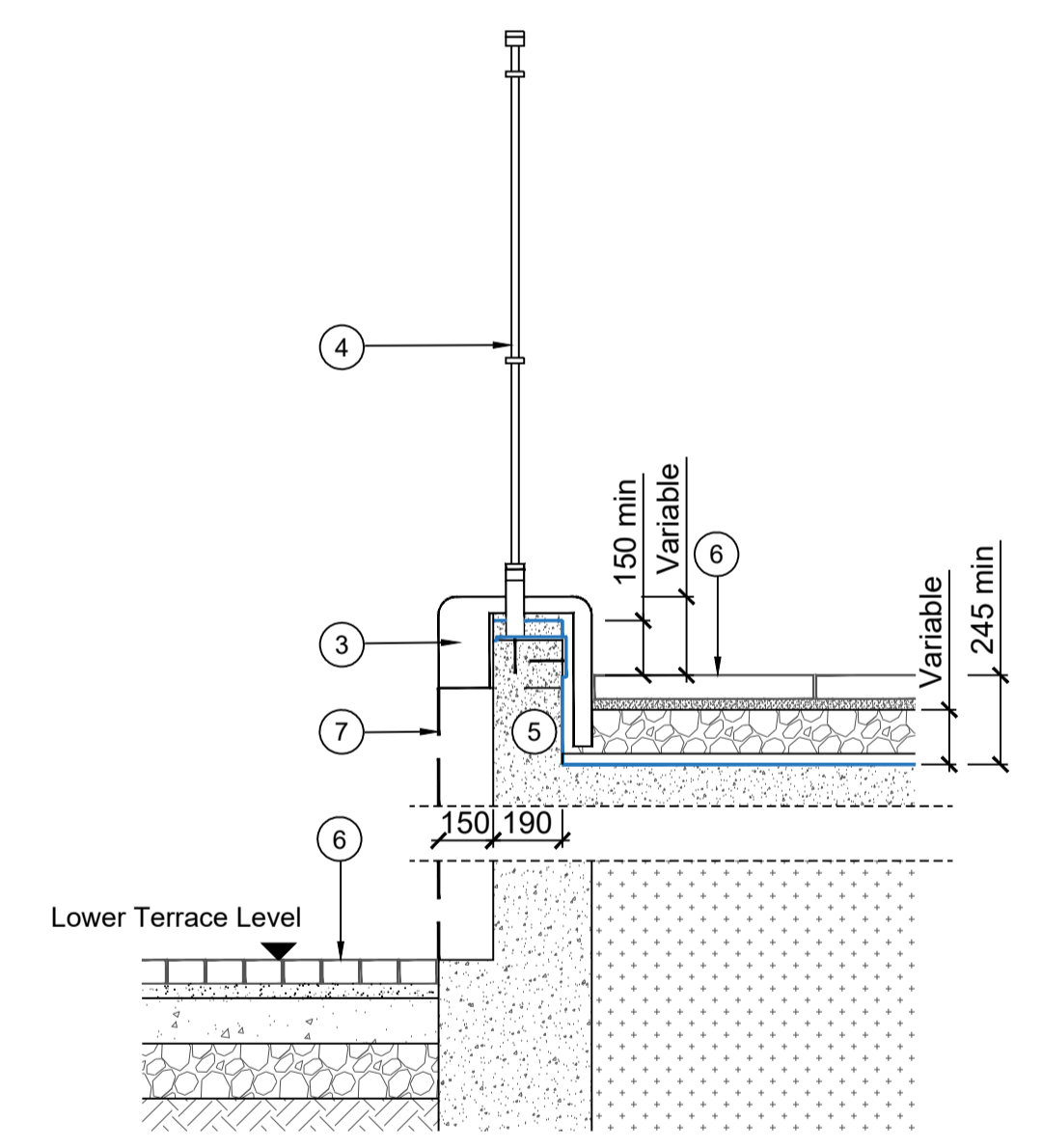

11  
03004 W2c - Balustrade Section  
Scale 1: 20 @A1

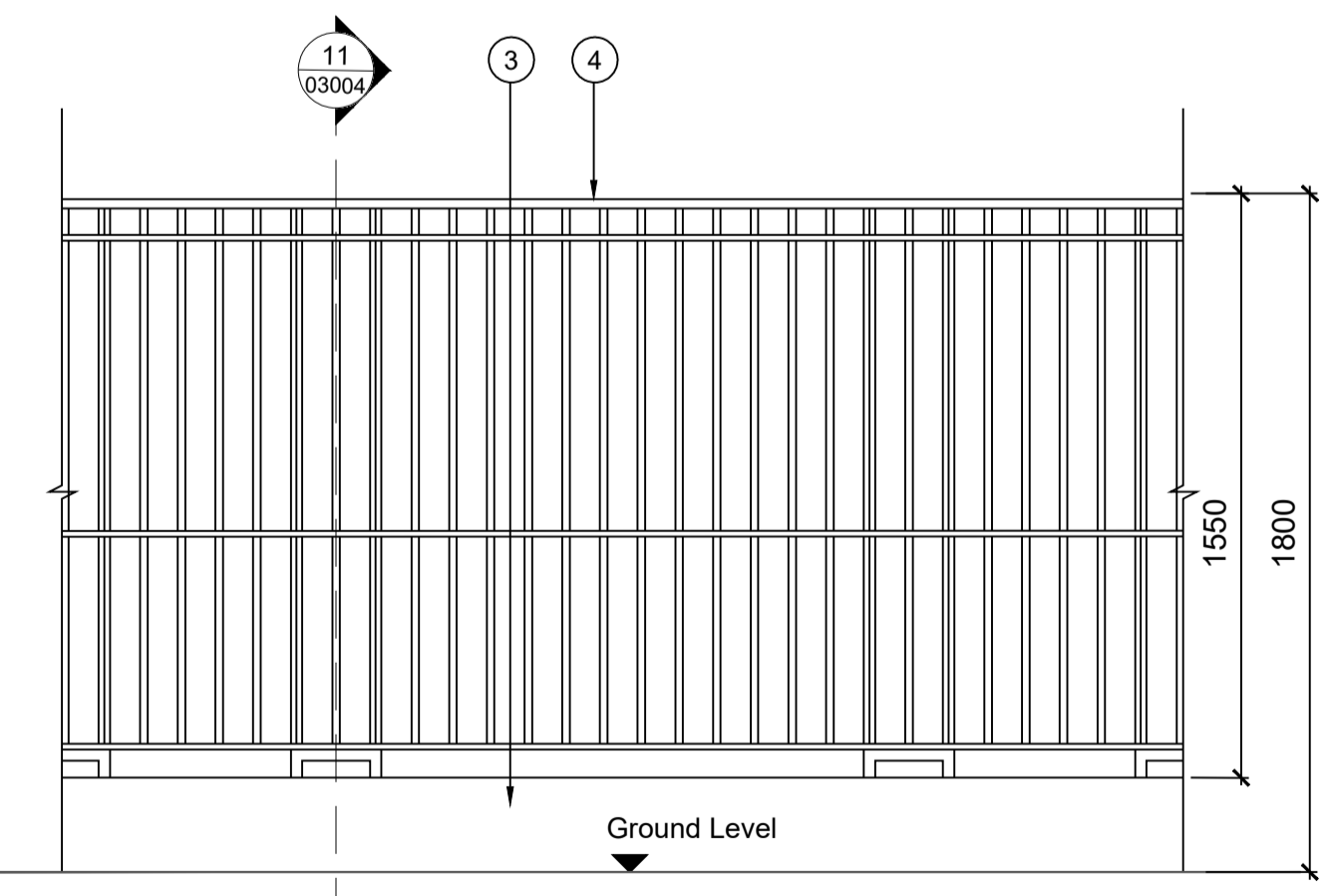

10  
03004 W2c - Proposed Retaining Walls with 1.8m High Balustrade and Metal Cladding Elevation  
Scale 1: 20 @A1

B1a/b - Refer to NBS Clause F21:110H  
B2 - Refer to NBS Clause F21:110I  
B3a/b - Refer to NBS Clause F21:110J  
W1a - Refer to NBS Clause F21:110A  
W1b - Refer to NBS Clause F21:110B  
W2a/c - Refer to NBS Clause F21:110C

- Proposed stone pier cap to match existing
- Proposed stone pier to match existing
- Proposed coping stone
- Proposed balustrade (NBS Clause Q40:410)
- Concrete retaining wall to Engineer's design
- Adjacent paving details to IR40300-GIL-ZZ-XX-DR-L-03000 Typical Paving Details
- Metal Cladding to to Architects design

**Notes**

- Do not scale from drawing, use figured dimensions only
- All dimensions to be checked onsite
- This drawing to be read in conjunction with all other Gillespies drawings and specifications

rev	details	by	date
P01	ISSUE FOR PLANNING	YH	22.08.2025
P02	Updated details and coding	YH	29.10.2025
P03	Updated B3 and W2a details	YH	14.11.2025
P04	STAGE 4 ISSUE	YH	03.12.2025
P05	Vent bench detail omitted	JF	18.02.26
P06	Issued for Planning	SH	26.03.2026

Project title  
**OUR CULTURAL HEART  
PHASE 2**

Drawing title  
**TYPICAL WALLS DETAILS  
- Sheet 1 of 2**

Drawing number		Revision	
IR40300-GIL-ZZ-XX-DR-L-03004		P06	
Date	Scale	Drawn	Checked
22.08.2025	1:20 @ A1	YH	JF

© copyright GILLESPIES LLP, all rights reserved

Client  
**Kirklees Council**  
Princess Alexandra Walk, Huddersfield  
HD1 2RS

**Gillespies**

5th Floor, Phoenix House, 3 South Parade, Leeds, LS1 5DX  
P: 0113 247 0550 F: 0113 247 0550 E: design.team@gillespies.co.uk