

**Carlow Concrete Method Statement**

## **ATTENUATION TANK INSTALLATION RIVA Homes, Croft St, Birkenshaw, Bradford, BD11 2HT**

- **IF ITS NOT SAFE , DON'T DO IT!**
- **ONLY WORK IN SAFE EXCAVATIONS.**
- **COMPLY WITH ALL PERMITS.**
- **IF IN DOUNT TALK TO YOUR SUPERVISIOR**
- **NEVER ENTER EXCLUSION ZONES.**
- **NEVER WALK UNDER SUSPENDED LOADS.**
- **USE SAFE SYSTEMS WHEN WORKING AT HEIGHTS.**

**NOTE-**

Inspection of the completed excavation will take place on the Wednesday prior to our start on the Monday. Due to programming of site crews and deliveries no excavation inspection will take place on Thursday or Friday we need to mitigate the risk if works are cancelled as all parties may incur costs with crews / pumps/ concrete/ transport etc.

Cancellation of the installation 72 hours before commencement will incur abortive works costs at our full daywork rate as per our quotation.

**Carlow Concrete Method Statement**

<b>CONSTRUCTION RECORD 1 Method Statement</b>	
<b>Site Address</b>	Croft St, Birkenshaw, Bradford, BD11 2HT
<b>Client</b>	Riva Homes
<b>Description of works</b>	Placement of precast external wall units, internal precast wall units , precast roof units, insitu floor, insitu roof screed and wall joints.
<b>Commencement Date</b>	To be confirmed
<b>RAMS Based on</b>	Construction Drawings
<b>Delivery Method</b>	40 foot trailers, delivery schedule as per programme.
<b>Placement Method</b>	Mobile Crane (Contract Lift) by Client
<b>Date</b>	18/07/2025
<p>Please review and either comment back with queries or concerns or confirm acceptance, please note no response will be deemed as acceptance.</p> <p>Prior to any work taking place all site operatives will have completed a Site Specific Induction and is briefed on the contents of this Method Statement.</p>	



**Carlow Concrete Method Statement**
**GENERAL PROCEDURE FOR INSTALLATION OF TANKS**

One week before work commences on site, check availability/decide on allocation of stability feet and lifters required. Advise Carlow Concrete of any requirements

**On arriving on site, adhere to the following procedures.**

1	Complete Site Induction Procedure, familiarize RAMS and sign on to RAMS	To comply with Statutory Legislation and Carlow Concrete requirements
2	Ensure Permit to Enter Excavations is completed by client. If the excavation looks unsafe, <b>DO NOT ENTER</b> Call the Carlow Concrete management team	To ensure safety of the installation crew and to comply with Carlow Concrete requirements
3	Complete Prestart Inspection, Part A Site Requirements	To ensure proper planning of the works
4	Ensure concrete pump and crane company personal familiarize and sign on to Carlow Concrete RAMS	To ensure that proper H&S procedures are adhered to
5	Before blinding commences, inspect in detail the setting out and the formation levels which is the responsibility of the client. <b>If any discrepancies are present and extra concrete is required;</b> 1. Notify Carlow Concrete, Denis Lawlor 2. Notify Client and get written sign off to proceed	To ensure Carlow Concrete can recover any additional costs incurred
6	Proceed with agreed procedures for the installation, adhering to RAMS at all times.	To comply with Carlow Concrete safety and QA requirements
7	Once the base slab is completed, remove stability feet from cast in box section and remove from excavation	To avoid trip hazards and ensure re-use of the stability feet
8	Ensure detailed photographs are taken at the stages as detailed in the <b>Weekly Site Records</b> documents and are communicated to Carlow Concrete	To ensure proper records are maintained. This is especially important in the event of any dispute arising.
9	Ensure all documentation is completed and returned as agreed with CC personal on completion of the installation	To comply with Carlow Concrete requirements
10	Ensure all extra over works, delays or any other events that may affect the works are recorded and signed off by the clients representative. Advise Carlow Concrete personal immediately by phone call or email should such events occur.	To enable Carlow Concrete to recover additional costs

**DO NOT**

**Carlow Concrete Method Statement**

- Commence works without site induction.
- Completion of the **Permit to Enter Excavations** by the client's representative, evaluation of safety of the excavation including access and egress.
- Commence concrete blinding without detailed checks on levels, fall etc.
- Deviate from agreed lifting procedures.
- Climb, jump or otherwise enter tank other than through suitable sized openings at **ground level only** or by certified scaffold and ladder access.
- Leave stability feet in place after base pour is complete.
- Allow a build up of debris inside/ outside of tank walls.

**DO**

- Proactively engage with the agreed procedures for installations (Method Statement / Risk Assessments).
- Complete site installation records daily.
- Promote good housekeeping and site cleanliness.
- Always present a professional appearance.
- Comply with any instructions from Carlow Concrete Management
- Record all works with detailed photographs and submit to Carlow Concrete

**Always work safely , do not walk past and ignore unsafe works.**

**If you think its not safe , STOP WORK immediately and report to the Site Manager and also call your manager to discuss the situation.**

**LIST OF SITE DOCUMENTATION FOR COMPETITION**

- Carlow Concrete Part A Prestart Checklist
- Permit to Enter Excavations
- Precast Tank Installation records
- Weekly Site Records (Time Sheets)
- Delays, extra over documentation (if required)
- H&S E Audit (if required)
- Any other documents as reasonably requested by Carlow Concrete Management

**Carlow Concrete Method Statement****Table of contents:**

1. Sequence of works
2. Risks and Controls
3. Technical Information
4. Emergency and Welfare arrangements
5. Training
6. Supervision
7. PPE
8. Adverse Weather
9. Environmental
10. Traffic Control
11. Rescue Arrangements

## **Carlow Concrete Method Statement Safe Work In Excavations**

### **Please Note-**

Site Foreman / Groundworks Foreman / Engineer, 2 of which must be present to complete the Carlow Permit to work in the excavation, the excavation will be deemed to be always a safe place of work. The permit will be completed by a competent person only.

Daily inspection of the excavation will be carried out by the site foreman as required and especially after inclement weather eg rainfall, movement of spoil next to the excavation, mobile equipment working adjacent to the excavation. All inspections to be recorded in Site Safety Folder which will be available from installation supervisor.

### ***Safe Excavation photos***



**Carlow Concrete Method Statement****1. Sequence of works****Summary of Sequence on site**

- Site Induction, Permits etc.
- Inspect excavation before work starts and that the excavation is deemed a safe place of work.  
**If it looks unsafe it is unsafe do not enter and call Carlow Installation Manager.**
- Client will have a well compacted stone base laid to falls as per the excavation/drawing detail and de-watering plan in place (if required).
- Carlow to lay 75mm concrete blinding concrete with concrete pump.
- All 4 corners to be marked out and agreed levels.
- Place the external wall units with the mobile crane.
- Reinforcement to base slab
- Pour the in-situ floor with the concrete pump. (See Carlow Concrete Drawing for details).
- Wall joint formwork and pour wall joints / Mobile crane and skip or concrete pump
- Pour the concrete wall infills
- Strike all formwork
- Place internal walls
- Place all the precast roof slabs into position / Mobile crane.
- Place mesh on the roof./ Mobile crane
- Pour the concrete roof topping./ Concrete pump
- Remove formwork and clear site.

**NOTE**

Concrete volume will be calculated prior to each pour by the Client to check independently on ordering.

Concrete will be called off by Client. This will be called off at a rate of 24 m<sup>3</sup> per hour which will require 3/4 trucks on turn around as a minimum.

Once the concrete wagons arrive on site **slump testing will take place by Client to confirm the required design mix slump requested @120 mm Pump Mix.**

If the required slump is not delivered to site, the Client Works Foreman will discuss the issue with the batching plant in order to resolve the situation.

**Water must never be added to the mix to achieve the required slump.**

The concrete is provided by Client and Client will be responsible for resolving the issue.

## **Carlow Concrete Method Statement**

### **Levelling strips and Blinding**

Safe access into the excavation and into the tank is required at all times.

It is critical the base of the excavation is clean, dry and in a safe condition before starting work.

The excavation must be free from groundwater while work takes place, Client will control this.

Subject to groundwater conditions this may necessitate a sump and pump at an appropriate location in the excavation.

- Site Engineer to set out blinding corners and give Carlow Concrete all corners of the tank (inside of the external Walls), grid lines to be agreed and mark out the required falls.
- Check all levels given on the drawing.
- Client to carry out survey on levels and confirm as required.
- Please note - Carlow is not responsible for site levels or setting out the works.
- Blinding will be placed with a correctly sized concrete pump with enough reach to cover the entire excavation.
- Carlow will not take responsibility on concrete overruns to the excavation blinding as this preparation work is outside our control.

***Safe access into the tank once all precast units are in place.***



### **Unload and Place external wall units and reinforcement.**

- The placing of the external wall units can now be placed onto the concrete blinded base.
- The concrete wall units are delivered to site on an articulated flatbed trailer.

### **Carlow Concrete Method Statement**

- These will be placed into position using the factory installed lifting eyes and swivel lifters.
- The mobile crane will unload and place the units. Carlow will supply 6m 5t web slings.
- Two Slings will be inserted under the precast units and dropped either side of the trailer.
- The chains will be connected to the slings.
- Once the slings are checked the unit will be lifted from the flatbed trailer and placed onto timber bearers on the base or adjacent to the works.
- Carlow supplied swivel lifters will be screwed carefully into the top of the unit.
- Lifting chains will be connected to the swivel lifters in the head/top of the unit.
- The crane will raise the units into the upright position slowly.
- Once upright the units will be slewed and placed into position.
- The toe of the precast unit has a protruding box section internally into the tank approx. 350 mm, at the back of the wall (external face) 2 no 80 mm x 80 mm box sections will be inserted into the cast in 90 mm x 90 mm box and these will protrude out from the back of the unit approx. 350 mm to support the unit (see below).
- The unit will sit on the levelling strip and the shims are used as a stability aid under the box section.
- When the precast wall units are in position the foreman will inspect the hydrophilic strip and carry out any remedial work if necessary.

#### **Steel Fix slab and wall joints .**

- The crane will lower the reinforcement rebar into the chamber.
- Concrete 40/50mm concrete bars will be laid out on the base to carry the rebar
- Mesh will be carried and placed by the operatives to complete the area.
- Tie wall joint reinforcement.
- Links will be fixed in place protruding into the floor and loose single bars tied into the wall joint U bars.
- L bars will complete the reinforcement from the wall joint into the roof screed.
- Once complete and inspected the floor can be poured.

**Once all the precast units are in place, temporary access scaffold will be required to gain access into the tank.**



## **Carlow Concrete Method Statement**

### **Floor Pour**

- Prior to commencing pour, a pre-pour inspection will be carried out jointly by the Client, Carlow representative and the Installation Foreman to confirm that the works are complete and in accordance with Carlow's design.
- Concrete volume will be calculated prior to each pour by the Client to check independently on ordering.
- Concrete will be called off by Client. This will be called off at a rate of 24 m<sup>3</sup> per hour which will require 3/4 trucks on turn around as a minimum.
- Once the concrete wagons arrive on site **slump testing will take place by Client to confirm the required design mix slump requested @120 mm Pump Mix.**
- If the required slump is not delivered to site, the Client Works Foreman will discuss the issue with the batching plant in order to resolve the situation.

#### **Water must never be added to the mix to achieve the required slump.**

The concrete is provided by Client and Client will be responsible for resolving the issue.

- The ready mix lorry will reverse into position and the concrete pump will be used to place the concrete. As the concrete is placed, poker vibrators will be used for compaction.
- The concrete will be discharged at an even rate to the required level.
- The indicated levels will be marginally over filled to allow for compaction / displacement of the concrete during compaction works. Laser level will be used to control levels.
- Vibratory pokers will be used to compact the concrete. Pokers will be sized to ensure that the full length of the poker can be inserted into the concrete. The pokers will be inserted into the concrete on a grid of approx. 400 /600 mm squares and held in place for 5 to 10 seconds or until such times as all air has been removed from the concrete. Care to be taken to ensure that over compaction resulting in segregated concrete does not occur.
- Concrete will be levelled and finished using an easy float / steel trowel.
- Curing Agent will be applied to the finished concrete only if required in warm / hot weather , when applied to fresh concrete it forms a micro crystalline seal in the pores reducing evaporation.

### **Wall Joints**

- Timber formwork is fixed in place to form the vertical joints between the precast walls.
- The formwork is fixed in place on the internal and external face of the precast wall with the use of Dywidag- fixing systems .
- 50mmx50mm box walers will be used with the formwork.
- Once the formwork is complete the joints will be poured with the use of crane -concrete skip / concrete pump.
- When completed the formwork will be removed the following day and the chamber cleaned out.

### **Placing the precast Internal Wall Units .**

- After the initial concrete set, a hardening time of 12 hours is required before the internal precast wall units can be placed on the floor slab.
- The precast units will be placed on a bed of mortar.
- The mobile crane will be used to unload and place the internal walls.

**Carlow Concrete Method Statement**

- The concrete wall units are delivered to site on an articulated flatbed trailer and/or curtain side trailers.
- Depending on size and weights ,3 units may be unloaded in each lift.
- Two Slings will be inserted under the precast units and dropped either side of the trailer.
- Once the slings are checked the units will be lifted from the flatbed trailer and placed onto timber bearers on the base or adjacent to the works.
- The wall unit will then be placed into position using the factory installed lifting eyes by the crane.
- Carlow supplied swivel lifters will be screwed carefully into the top of the unit.
  
- Stability feet will be fixed in place into the precast unit and shimmed for line and level .

***NOTE- Stability feet must be fixed in place both sides of the wall unit at all times to secure the stability of the unit.***



**Carlow Concrete Method Statement**
**Internal Unit**

	m	mm	L (m)	E	S355 SHS	
Height	Depth	Stabiliser Length	Stabiliser Extension	Stabiliser Section	No. of Stabilisers	
1.00	275	0.400	0.063	80 x 80 x 4	1	
1.25	275	0.400	0.063	80 x 80 x 4	1	
1.50	275	0.400	0.063	80 x 80 x 4	1	
1.75	275	0.450	0.088	80 x 80 x 4	1	
1.99	275	0.500	0.113	80 x 80 x 4	1	
2.19	275	0.550	0.137	80 x 80 x 4	1	
2.50	275	0.625	0.175	80 x 80 x 4	1	
2.75	275	0.675	0.200	80 x 80 x 4	2	
2.90	275	0.725	0.225	80 x 80 x 4	2	
2.99	275	0.775	0.250	80 x 80 x 4	2	
3.29	275	0.800	0.262	80 x 80 x 4	2	
3.49	275	0.850	0.287	80 x 80 x 4	2	
3.59	300	0.900	0.300	80 x 80 x 4	2	
3.69	300	0.900	0.300	80 x 80 x 4	2	
4.00	300	0.975	0.337	80 x 80 x 4	2	
4.20	300	1.025	0.362	80 x 80 x 4	2	
4.25	300	1.025	0.362	80 x 80 x 4	2	
4.50	300	1.100	0.400	80 x 80 x 4	2	
4.75	300	1.200	0.450	80 x 80 x 4	2	
5.00	300	1.250	0.475	80 x 80 x 4	2	
5.25	300	1.300	0.500	80 x 80 x 6.3	2	
5.50	300	1.350	0.525	80 x 80 x 6.3	2	
5.75	300	1.400	0.550	80 x 80 x 6.3	2	
6.00	300	1.450	0.575	80 x 80 x 6.3	2	

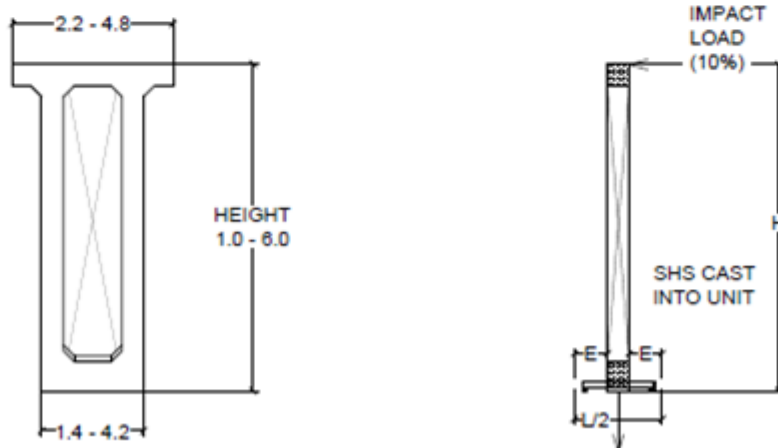

## Carlow Concrete Method Statement

- A mortar bed will be used on the internal and external wall units to ensure continuous uniform bearing of the precast roof units.
- The mortar bed under the units will be pointed and cleaned as the installation progresses.
- When the placement of the internal walls is completed the precast roof slabs are offloaded and placed in position.
- Once the roof slabs are being placed the stability feet will be removed and top and bottom of the walls are pointed up and floor swept clean.



### Placing the precast Roof Slabs

- A minimum 90 mm bearing is required for the roof slabs.
- Precast roof slabs are delivered on a flatbed truck each. ***Please see Carlow Concrete drawing for all precast weights.***
- Place the slings under the precast roof slabs and attach the chains, lift the units from the trailer and place next to the works area.
- Using the chains clip onto the cast in lift loop embedded into the precast unit, lift and place into position
- The site operatives will wear harnesses at all times as work takes place on the roof slab.
- A ladder will be used to get onto the roof slabs, secured, and in good condition at all times.
- The first slab will be lifted into position by the mobile crane, the operative will be on the alloy podium to place the mortar bed and can observe the slab is in the correct position.
- The placing of the first slab is an uncomplicated process.

**Carlow Concrete Method Statement**

- Once the first slab is in position the site operative will access the slab by ladder or scaffold walkway and clip onto the cast in lifting eye. The site operative will now stay on the slabs as further slabs are placed.
- At all times the site operative will be wearing 2 retractable lanyards and as he moves forward on the slabs he is clipped onto the slab in front as he is unclipping the lanyard behind. This process will be repeated until all the slabs are in position and the handrail is in place.
- Site will have a safe access point onto the tank roof for operatives to access the roof and start placing the units .

## Note-

- Working with short lanyards the operatives would be restrained from getting to the edge of the roof slab as it is being placed , site will have scissor lifts in the tank as we will be removing chains from the roof slabs and these will be used to rescue the operative in the event he gets to the edge and has an incident .
- Leading edge protection will be on place prior to the roof mesh being placed and also in place until the roof screed is poured.

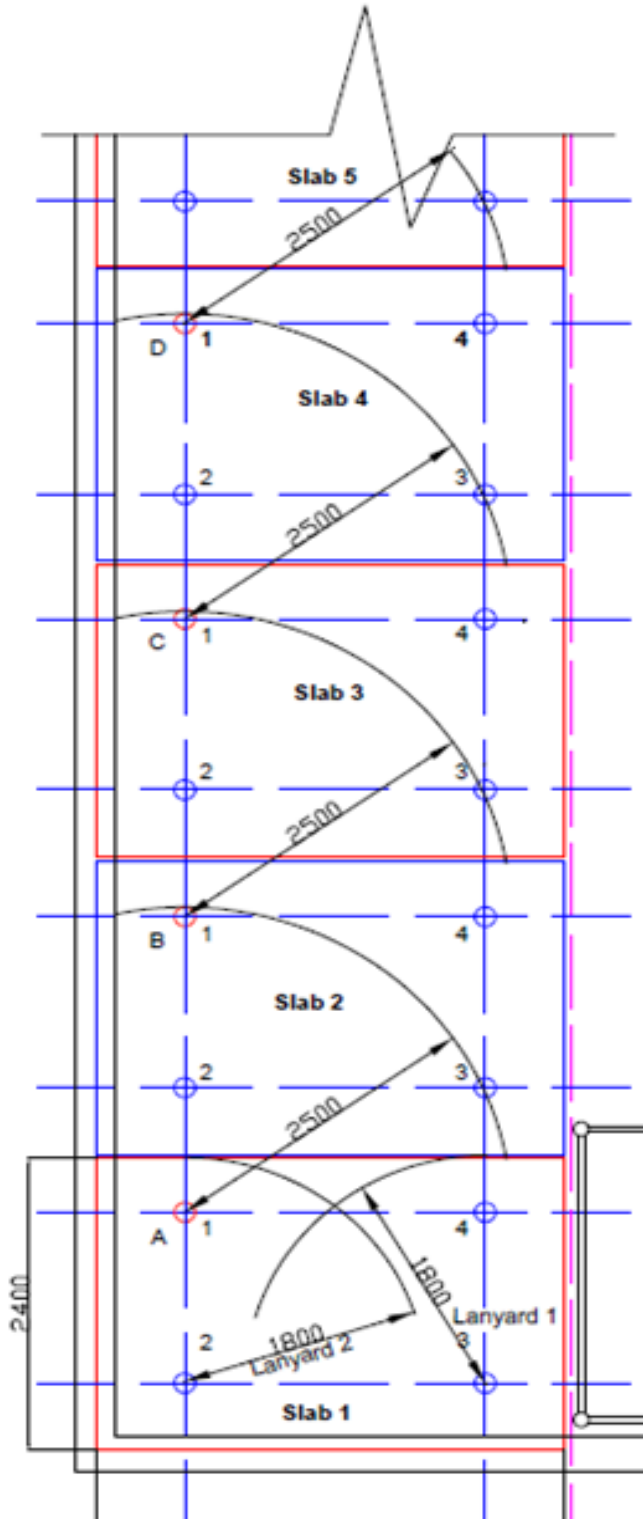
**Carlow Concrete Method Statement**

**Slab dimensions (mm)**

- A. Only tie onto the red marked (circles) lifting points. Do not tie on to any other points. If necessary, use capstan lifters anchored to the appropriate lifting eye.
- B. Roof operative to wear 2 no. fall prevention lanyards, max allowable free play 2.5m
- C. Perimeter handrail must be in place before any installation commences
- D. Bedding mortar placed from ground level by ground crew.

**Procedure**

1. Fix 2 no. fixed length 1800mm to roof slab 1 before lifting as shown. Place slab 1 from ground level only into final position
2. Remove chain 3 and 4. Remaining tied to lanyard 1, tie onto lanyard 2, then remove lanyard 1, then remove chains 1 & 2. Remain in position until roof slab 2 is approximately placed.
3. Slab 2. After approximate placing of slab 2, tie onto position A with fixed length retractable lanyard, max length 2500mm. Hook spare retractable lanyard onto harness. Return fixed length lanyards to ground crew. Complete the placement of the slab 2. Remove chains 1,2,3. Ground crew removes chain
4. Slab 3. Remain tethered to point A until roof slab 3 is in approximate position. While tethered to point A, use the second lanyard to tie onto point B, then untie from point A hooking spare lanyard onto body harness. Remove chains 1,2,3. Ground crew removes chain 4.
5. Slab 4. Remain tethered to point B until roof slab 4 is lifted into approx. position. While tethered to point B, use the second lanyard to tie onto point C, then untie from point B hooking spare lanyard onto harness. Complete placement of slab 4. Release chains 1,2,3. Ground crew release chain 4.
6. Continue until all slabs in the run has been completed. Roof operative then returns to ground by reversing the steps in stage 2. .Mobile access

**Carlow Concrete Method Statement****Roof (as required wall joint) pour.**

- Once all slabs are in position and the perimeter **handrail / scaffolding** erected, works can proceed without safety harnesses.
- All roof openings must be covered before further construction takes place. Plywood will be fixed into position by Carlow over the openings.
- Place one layer of reinforcement mesh strip (.600mm )over the roof slab joints.
- A concrete **125 mm screed on 125 mm** solid precast concrete slab is applied to the roof and wall joints simultaneously.
- Concrete volume will be calculated prior to each pour by the Client to check independently on ordering.
- Note , details above as per the base pour .
- The Concrete pump will be used for this operation.

**Please note**

- Prior to casting the roof screed, the surface of the precast slabs should be brushed clean of all debris if required.
- The precast slabs should if required be dampened down with water but should not have standing water when applying the concrete screed. Water bowser and sprayer can be used.
- Curing agent is applied to the finished roof slab in warm weather.

**Cleaning and making good prior to placing roof slabs.**

- On adequate curing of the wall joints operatives enter the tank to remove formwork. Cleaning and making good will also be carried out at this time.
- Primary access to the tank will be a tower up to the tank and a ladder into the tank.
- Scaffolding access will be amended to suit site conditions.
- Operatives must ensure that the generator is placed in a position that will not allow any fumes from the exhaust system to enter the tank.

**Confined space procedure.**

As a minimum once the tank is closed the following will apply.

Gas monitors will be used at all times, both before entering the tanks and while the work is being carried out. Testing of oxygen content will be carried out first, while the monitors being used will also test for common asphyxiating contaminants such as carbon monoxide, carbon dioxide, or hydrogen sulphide. The equipment will be currently calibrated in accordance with the manufacturer's recommendations.

As a further precaution, persons working inside the tank will carry an emergency breathing apparatus device allowing the user adequate time to exit the tank should a change in atmosphere occur.

The operative at the access point will have responsibility for the tripod and winch placed over the access opening.

Operatives accessing the tank will have completed confined space training.

All operatives will have training certs for confined space entry and certs for the monitoring equipment.

Note – Monitoring equipment will be hired in from a specialist supplier and will have all statutory checks and certs in place.

All works inside the tank once complete will be controlled by a confined space entry permit procedure.

**Carlow Concrete Method Statement****Backfilling**

Please find attached data sheet on backfilling the tank.

Do not allow a track machine onto the slab before the slab is covered with spoil as the tracks may damage the roof screed.

Backfilling should be completed in horizontal layers as per best practice.

(Note: Excessively heavy compaction can damage the tank).

Backfilling should only commence 10 days from completion of the concrete roof screed.

Do not allow a track machine onto the slab before the slab is covered with a minimum spoil depth of 800 mm, as the tracks may damage the roof screed.

Backfilling should be completed in horizontal layers as per best practice, after the initial 800 mm of overburden is placed.

Don't use any vibrating rollers until there is at least 500 mm of soil placed.

Avoid heavy plant congregating in one area of the tank as the design assumes all wheel loads are shared out over adjacent cover slabs.

Max Vehicle Weights permissible after placement of roof screed.

Up to Day 9 – No vehicle loading

Day 10 – Back filling to top of roof level

Day 15 – Backfill of roof to design levels using maximum, 14 Tonne gross vehicle/plant weight

Day 21 + – Maximum 26 T (HGV) gross weight.

Please contact Carlow Concrete regarding loadings (size of track machine) when backfilling the top or sides of the installation and we will confirm if the following applies.

Contact details – office 0207 1646706 Denis Lawlor 075174 29507

**2. Risks and Controls**

Please see Part C Risk Assessments for the installation works.

**3. Technical Information**

Carlow Concrete will issue -

Installation / construction drawings.

RAMS

COSHH assessments.

**4. Emergency and Welfare arrangements**

Emergency Procedures shall be in accordance with those detailed in the site induction.

First aiders and first aid box location information will be discussed at the site induction and also the assembly point and site alarms. Client will supply welfare facilities to Carlow .

**5. Training**

Site Safety induction will be carried out by the main Contractors Representative.

### Carlow Concrete Method Statement

Installation operatives will have in their possession current and in date CSCS cards.  
 Carlow Concrete dictates all operatives to wear PPE as required when working on site.

#### 6. Supervision/ Communication

Supervision will be carried out by Installation Foreman  
 Carlow Contracts Manager Steve Green 07492 513350  
 Daily briefings will be carried out to discuss the day’s work with site team / crane / concrete pump operators etc. Toolbox talks will be attendee by install crew carried out by Client / Carlow  
 Whiteboard talks AM daily with Site Manager/Carlow

#### 7. PPE

Appropriate PPE shall be used by all working on or accessing these works. The wearing of the following PPE is always mandatory: safety helmet, safety footwear, hi-visibility jacket/vest, eye protection and gloves.  
 Other PPE may be necessary depending on the activity and will be identified in the specific Risk Assessments.  
 List of task specific PPE required but not limited to:

Hard Hat	Anti – Vibration Gloves
Dust Mask	Safety Harness
Gloves	Ear Defenders
Safety Boots	Safety Glasses
Hi Vis Vest / Coat	Escape Set
CSCS / SSSTS	Training CSCS /Confined Space / Manual Handling

#### 8. Adverse Weather

Concrete pours will not go ahead in cold freezing weather. Concrete placement is dependent on weather conditions and temperatures being within specification limits or in accordance with best industry practice (British Standards, Eurocodes etc.)  
 Postponement of concrete placement due to inclement weather is not cause for breach of contract or ascertained losses.

#### 9. Environmental

The Installation Team will seek to keep waste to a minimum and maximise the efficient use of materials, energy and other resources whilst managing and disposing of all waste in a responsible manner to site skips.  
 All unused concrete will be returned to the batching plant and disposed in a safe manner.  
 Timber and plywood from formwork will be removed from site and recycled

#### Hazardous substances to be used on site.

- Hydrotite CJ
- Soudal
- Concrete

**Carlow Concrete Method Statement**
**10. Traffic Control**

On arrival of a delivery to site, Client will ensure that a banksman/flagman / competent person is available to assist in delivery.

- Client will be always responsible for control of all traffic on site.

**Also:**

- Ensure the delivery driver has completed the induction procedure.
- When reversing the delivery into position on site, they must ensure the safety of pedestrians and on-coming traffic.
- When the delivery is in position, they must ensure the free flow of traffic and pedestrians, while the delivery is being unloaded
- When the Carlow Concrete delivery is unloaded, the competent banksman/flagman will escort the vehicle to the exit and assist in getting the vehicle out on to the public road safely.
- At all times the banksman/flagman should ensure the safety of pedestrians and on-coming traffic.

**11. Rescue Arrangements**

<b>CONFINED SPACE ON-SITE RESCUE PLAN</b>	
Confined Space Name/Location: Project Number:	
Installation Company: <i>Carlow</i>	Employer:
Employer: <i>Carlow Concrete</i> On-Site Rescue Personnel: TBC on site prior to entry	
Methods of Communication: via Top Man	
Methods of Rescue: <input type="checkbox"/> External (Retrieval) <input type="checkbox"/> Internal: _____ <input type="checkbox"/> Congested: _____ <input type="checkbox"/> Hauling System Required: <i>Tripod &amp; Winch</i> <input type="checkbox"/> Patient lowering system required/lowering area: _____ <input type="checkbox"/> Anchor overhead: <u>Tripod</u> _____ Anchorage: <input type="checkbox"/> Beam <input type="checkbox"/> Stairwell <input type="checkbox"/> Support Strut <input type="checkbox"/> Support Column <input type="checkbox"/> Other: _____	
Rescue Equipment Requirements (check <input type="checkbox"/> where applicable below and indicate quantity needed): <input type="checkbox"/> Hauling Systems: __ <input type="checkbox"/> Winch with Tripod: <u>Yes</u> <input type="checkbox"/> Pulleys: _____ <input type="checkbox"/> Shock absorbers/lanyards: __ <input type="checkbox"/> Anchor Straps: _____ <input type="checkbox"/> Webbing: _____ <input type="checkbox"/> Ascenders: _____ <input type="checkbox"/> Body Harnesses: _____ <input type="checkbox"/> Rigging Plates: _____ <input type="checkbox"/> Safety Lines: _____ <input type="checkbox"/> Main Lines: _____ <input type="checkbox"/> Wrist/Ankle Harnesses: __	
Rescue Equipment Inspections Identified rescue equipment inspected by competent worker: _____ Employer: _____ Record of inspection(s) attached <input type="checkbox"/> Yes	

**Carlow Concrete Method Statement**

Medical Equipment Requirements (check  where applicable below and indicate quantity needed): O

First Aid Kit: \_\_\_\_\_ O Packaging Device: \_\_\_\_\_

Additional PPE Requirements (Indicate what is needed):

High Visibility Vests / Hearing Protection / Safety Boots / Hard Hats / Safety Glasses/Goggles / Gloves / Face Shield / Gas Detection / Breathing Apparatus

**Description of Space (include location of attendant):**

- The space is a below ground water storage tank (not in service).
- The tank is 2.5m deep internally, divided into lanes by internal wall units.
- Main access is scaffold tower and ladder drop into the tank.
- There are manway openings in the cover slab, one of which will be utilized for emergency evacuation and will have a tripod and winch installed thereover.
- Prior to entry, all Method Statements will be read, completed & signed.
- All PPE requirements will be adhered to in accordance with this plan.
- A Tripod and winch will be installed over a cover slab manway.
- Operatives entering the space will be wearing harnesses.
- Persons requiring rescue will be connected to the tripod & winch over head via their harness and winched out of the structure.
- Where necessary first aid will be administered immediately until the paramedics arrive.
- Under no circumstances should any person attempt to enter the space, even for the purposes of retrieving another person until the space has been reassessed for gases/collapse and cause of illness of persons within.
- Emergency services will be notified immediately.

Note: The acceptable oxygen concentration range is between 19.5% and 21%. Work must not be undertaken if the oxygen concentration is outside this range.

A gas detector will be stationed within the space adjacent to the operative's work area. In the event the gas detectors alarm is sounded, the operatives will immediately exit the tank leaving all equipment and personnel belongings behind them.

**PLEASE SEE CARLOWS DRAWING FOR ACCESS POINTS**

Date : \_\_\_\_\_

Completed by: \_\_\_\_\_

Entry Supervisor

Attendant

Other

**Appendix A**  
**Unloading Mesh Reinforcement**

---

**DO NOT LIFT BUNDLES USING THE BUNDLE TIES. THEY ARE NOT CLASSED AS LIFTING EQUIPMENT AND ARE THEREFORE UNSAFE FOR LIFTING PURPOSES.**

**Carlow Concrete Method Statement**

**ALL ACCIDENTS ARE PREVENTABLE IF BEST PRACTICE WORKING PROCEDURES ARE ADHERED TO, SUITABLE PPE IS ISSUED, AND PROPER TRAINING AND CORRECT SUPERVISION ARE PROVIDED. THESE COMBINED WITH A 'THINK SAFETY' ATTITUDE CAN SUBSTANTIALLY REDUCE THE LIKELIHOOD OF ACCIDENTS.**



The illustration shows a worker climbing a stack of rebar on the back of a truck. A large red 'X' is superimposed over the worker, indicating that climbing the rebar is unsafe. The truck has two axles and wheels visible.

**DO NOT** climb up the fabric on the vehicle. Use a ladder or another appropriate means of access, such as a gantry platform. If a ladder is used, ensure that it is secured.

**WHEN USING LADDERS, ALWAYS MAINTAIN THREE POINTS OF CONTACT**

**Carlow Concrete Method Statement**

BEST PRACTICE GUIDANCE  
THE SAFE OFF-LOADING OF REINFORCEMENT FABRIC

## DUNNAGE

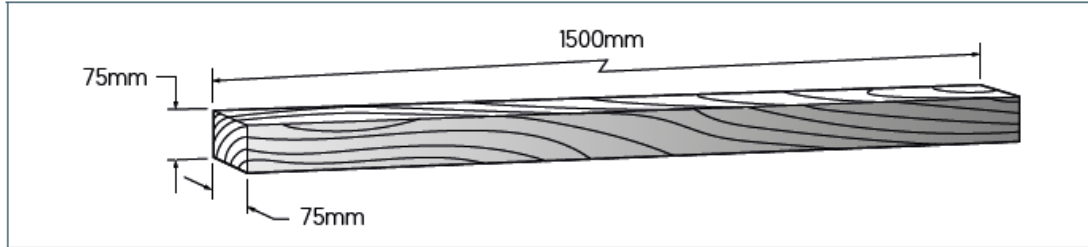

Bundle ties should only be used for raising the load to facilitate insertion of dunnage. The bundle ties must not be used to lift bundles but may be used to raise one corner of a bundle at a time for the placement of dunnage to provide clearance for chains/slings to be looped through the reinforcement fabric.

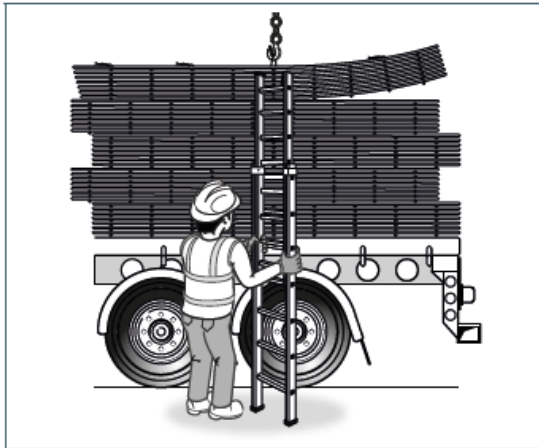

Move the ladder away from the vehicle before lifting the bundle to place the dunnage

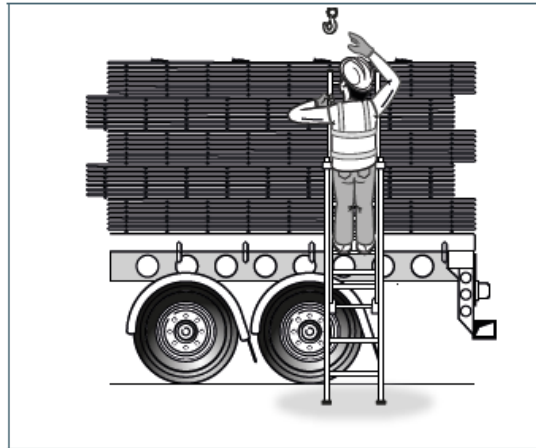

Reposition ladder to place dunnage under corner of bundle

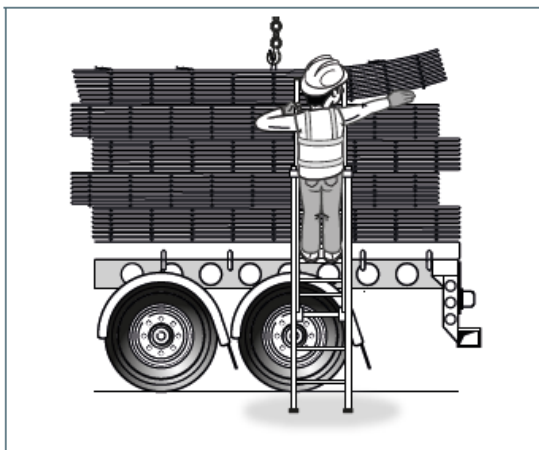

Lift one corner at a time at sufficient height to allow dunnage to be placed under bundle. Never put hands under the raised bundle.

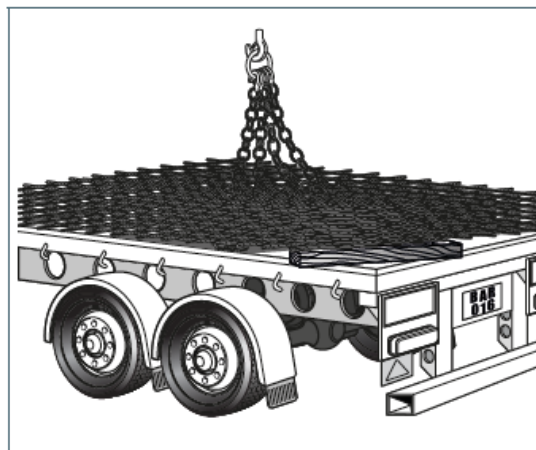

Pass the chain through the bundle and put the hook back into the master link [or pass a strop through and attached the eyes to the crane hook]

## Carlow Concrete Modular Precast Concrete Tank

### Technical Guidance on Backfilling Operations

With regards backfilling and reinstatement of ground to design levels we comment as follows:

Backfilling may commence 10 days after completion of the concrete roof screed.

Do not allow machinery with tracks onto the roof/cover slab before a minimum spoil depth of 0.6m is achieved, this is to prevent damage the roof screed.

Backfilling should be completed in horizontal layers as per best practice, after the initial 0.6m of overburden is placed.

Do not use any vibrating rollers until there is at least 600mm of soil placed.

Avoid heavy plant congregating over any one area of the tank as the design assumes all wheel loads are shared out over adjacent cover slabs.

#### *Max Vehicle/Machinery Weights permissible after placement of roof screed:*

- Up to Day 9: No vehicle loading
- Day 10: Back filling to roof level only, i.e. to top of walls but no material placed on roof slab
- Day 15: Backfill of roof to design levels using maximum, 13 Tonne gross vehicle/plant weight
- Day 21+: Maximum 26T (HGV) gross weight

**\*\*IF IN DOUBT PLEASE CONTACT CARLOW CONCRETE FOR GUIDANCE\*\***

## On Site Storage of Prestressed Roof Slabs

- Suitable timber bearers need to be inserted between individual units as indicated in the diagram , these must be kept in vertical alignment
- The height of each stack should be limited to prevent the need for slingers to climb onto the stack of slabs.
- For wideslab units the timber bearer position X on slabs up to 5m should be taken as a min 300mm
- Adequate lay down area to be in place if not unloading and directly placing units.
- The laydown area must be firm and level ie. compacted hardcore .

**NOTE-**At all times double handling of the slabs increases the risk of damage .

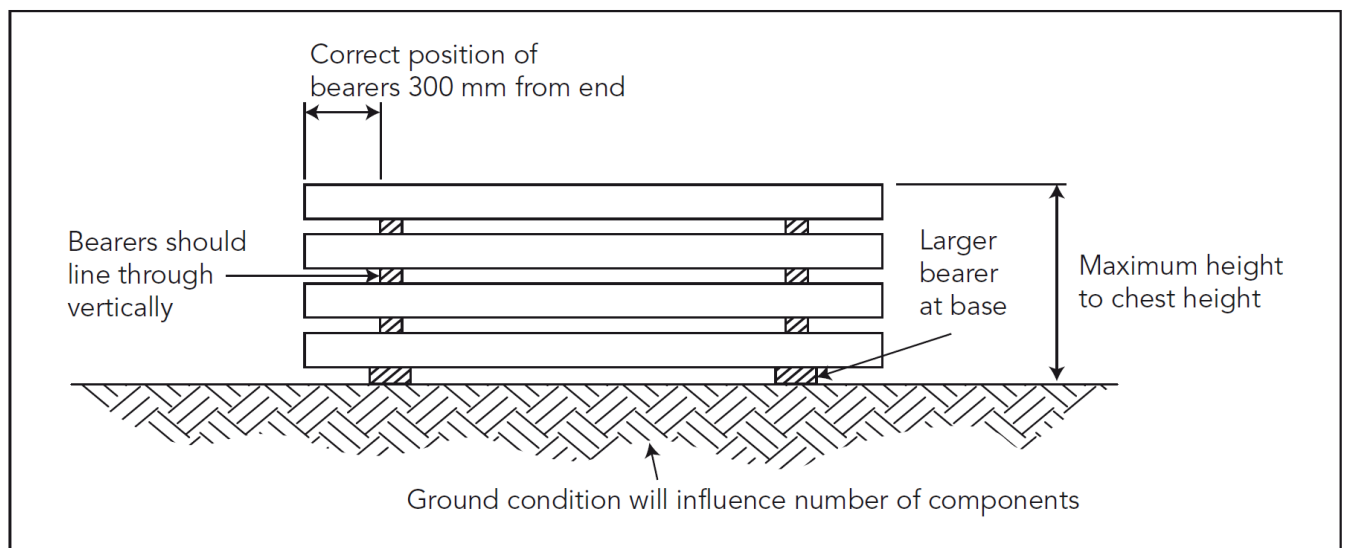

- *Correct Stacking method.*