



strata

**DRAINAGE MAINTENANCE AND
MANAGEMENT REPORT For:**

Westgate, Cleckheaton

Date: February 2026

Prepared by: Nathan Eastwood

Date: 27/11/2023

Checked by: Andy Carr

Date: 27/11/2023

Document History

Revision & Amendment Record			
Rev	Date	Revision Details	Revised by
A	04/09/24	Note added to Section 1.2 for discharge rate. Note added to Section 2.3 to confirm process if YW do not adopt. Headwall section removed and Appendix A and C updated to suit latest design.	NE
B	11/09/2024	Comment added to Section 2.3 for design life of cellular attenuation tank	NE
C	13/11/2025	Section 104 plan within Appendix A updated to latest with updated outfall location	NE
D	26/11/2025	Reference to 'CASCADE' removed from document	NE
E	03/02/26	Amended to suit LLFA consultee comments dated 30 th Dec '25	NE

TABLE OF CONTENTS

<u>Section</u>	<u>Title</u>
1.	INTRODUCTION
2.	MAINTENANCE AND MANAGEMENT REGIME
3.	CONTACT DETAILS AND RECORD OF MAINTENANCE

Appendices

APPENDIX A – Maintenance and Management Plans

APPENDIX B – Cellular Attenuation Tank

APPENDIX C – Flow Control

APPENDIX D – ACO StormBrixx Maintenance and Inspection Manual

INTRODUCTION

1.1 General

This report has been provided to support a planning application for the development comprising of 180 No. new residential dwellings at Westgate, Cleckheaton, BD19 5DR. A discharge of conditions planning application has been submitted (ref: 2023/93077) from which a consultation response from the Lead Local Flood Authority at Kirklees Council has been provided. The consultation response for Condition 15 states "a maintenance and management plan including any certification, (eg. British Standard or BSE Certificate) should be included in this pack. A management company is expected to pick this up until such a time that it is adopted by a statutory undertaker."

Sustainable Urban Drainage Systems (SuDS) are a sequence of water management practices and facilities designed to drain surface water in a manner that will provide a more sustainable approach than what has been the conventional practice. SuDS are designed to mimic natural drainage flows and typically manage rainfall close to where it falls. Benefits include the effective management of runoff from hard standing surfaces, such as pavements and driveways, by reducing the volume, frequency and flow rate of surface water runoff during extreme storm events. They provide protection and/or enhancement of water quality (reducing pollution from runoff), are sympathetic to the environment and the needs of the local community.

The purpose of this management plan is to demonstrate how SuDS, which have been implemented at this particular residential development will be maintained in compliance with various requirements and best practice guidance, including but not limited to, the National Planning Policy Framework (NPPF) and SuDS Manual (CIRIA, 2015).

The management plan aims to:

- Summarise the various SuDS features used within the site;
- Establish who is responsible for the maintenance of the SuDS components;
- Set out how to maintain the incorporated SuDS components following construction;
- Ensure that all those involved in the maintenance and operation of the SuDS understand their functionality and maintenance requirements in terms of supporting long-term performance.

Maintenance inspections should be recorded in Section 3.2 of this report to ensure that the document stays up to date.

1.2 Site Description

The proposed development consists of 180 No. new dwellings accessed by a proposed adoptable road from A643 Westgate, within the town of Cleckheaton.

The site is brownfield with three existing buildings that are due to be demolished to make way for the development. There is an existing private road (Stone Street) that is used to access the site, which will be stopped up to construct the adoptable access road.

There are a series of public foul sewers crossing the site, which will be diverted under a Section 185 agreement with Yorkshire Water. Where crossing within open spaces, an easement in accordance with Yorkshire Water's guidance is to be provided. Blacup Beck borders the site to the south, and it is culverted via a 900mm dia. pipe when crossing the site. The culvert is to remain as part of the development.

The surface water drainage system for the development comprises of a cellular attenuation tank to store the 1 in 100 year storm event plus a 30% allowance for climate change. A flow control chamber is to be installed to restrict the development to greenfield rates. A greenfield runoff rate of 26.5 l/s was originally agreed with Kirklees Council, however following further discussion, the Lead Local Flood Authority commented that "We estimate to avoid double counting of preserved landscaped areas, that a greenfield discharge restriction of 25l/s is appropriate for this site" within a consultation response dated 28th November 2021. Runoff generated from the adoptable highways, new dwellings and associated parking will utilise the tank for attenuation at 25.0 l/s.

The main sewers within the network are to be maintained by Yorkshire Water under a Section 104

agreement.

A plan showing the proposed drainage to be maintained is shown in Appendix A.

1.3 Background to Surface Water Strategy

The surface water drainage scheme for the development has been based on the Flood Risk Assessment and Drainage Strategy produced by Queensberry Design Limited dated February 2023, ref: QD1776 FRA.

The hierarchy of surface water disposal methods has been assessed within the above report by Queensberry Design Limited, with infiltration being discounted due to clay soils and contamination underlying the site.

Blacup Beck is located to the south of the development and is to be utilised as the outfall for the surface water runoff from the development. As explained within Section 1.2, a runoff rate of 25.0 l/s has been agreed with Kirklees Council.

The foul water created by the development will connect into the diverted combined public sewers crossing the site.

MAINTENANCE AND MANAGEMENT REGIME

2.1 General

Homeowners will be responsible for maintaining the private drainage serving their dwelling. They must fully understand their responsibilities outlined in this plan and be aware of any legally binding maintenance agreement.

Only trained personnel will be permitted to undertake maintenance of SuDS features where responsibility lies with Private Management Companies, Yorkshire Water or Kirklees Council. This work must be carried out in accordance with the Confined Space Regulations. To facilitate this maintenance, the features outlined within this report have been located where reasonably accessible, where practical to do so.

Tables outlining the maintenance activities that should be undertaken for each SuDS feature, outlined in the following sections, in accordance with the SuDS Manual, CIRIA, 2015. These tables must be reviewed by the Homeowner, Yorkshire Water and Kirklees Council.

Under the Town and Country Planning Act 1990, a Management Company involving all property owners shall be set up for all drainage features noted within this report, should adoption not occur by Yorkshire Water or a NAV.

2.2 Inspections and Reporting

An initial pre-handover inspection will be required to ensure that the drainage elements have been constructed in accordance with the design.

All inspections and maintenance activities shall be carried out by staff with an appropriate level of experience in drainage maintenance. All inspections shall be recorded, and records kept for future reference.

During the first year of operation, inspections shall be carried out at least monthly and after significant storms, to ensure correct functioning of all components.

2.3 Cellular Attenuation Tank

Cellular attenuation tank is to be installed within the public open spaces within the southern section of the site. They are to store surface water runoff for storm events up to and including the 1 in 100 year plus a 30% allowance for climate change. The cellular attenuation tank will be under the responsibility of Yorkshire Water, subject to a Section 104 agreement.

Access turrets are to be provided at all inlet and outlet locations for maintenance. A catchpit chamber (Manhole S25) is to be constructed upstream of the attenuation tank to prevent siltation of the tank, with a low flow channel running beneath the tank to the flow control chamber downstream.

The cellular attenuation tank proposed is the StormBrixx HD900 model by ACO. Refer to Appendix B for the StormBrixx HD900 and access unit data sheets, and manhole S25 detail.

Details of the maintenance regime for cellular storage systems prior to the adoption handover are provided in the table below:

Maintenance Regime	Required Action	Typical Frequency
Regular Maintenance	Inspect and identify any areas which are not operating properly, take remedial action if required.	Quarterly for first year, then annually
	Remove debris from the catchment surface where it might cause risk to performance.	6 Monthly
	Remove sediment from pre-treatment structures.	Annually or as required.

Remedial Actions	Repair/rehabilitate inlets, outlets, overflows, vents etc.	As required.
Monitoring	Inspect inlets, outlets, overflows, vents etc. to ensure correct operation in accordance with design and in good condition.	Annually
	Survey inside for sediment build-up and remove if necessary.	Every 5 years or as required.

Yorkshire Water will be responsible for the maintenance of the attenuation tank subject to the completion of a Section 104 agreement, therefore the attenuation tank will be constructed in accordance with Code for Adoption 2020.

Should Yorkshire Water not wish to progress with the Section 104 agreement to adoption stage, Strata Homes will pursue other routes to obtain Section 104 adoption, via a NAV. This will be for all drainage being offered for adoption noted on the Section 104 Agreement Plan within Appendix A.

As noted within Appendix B ACO StormBrixx HD900 has a design life of 60 years. Should a Section 104 agreement not be completed with Yorkshire Water or a NAV, the tank is to be replaced before the end of the design life.

For maintenance and inspection of the ACO StormBrixx HD900 units, refer to Appendix D.

2.4 Flow Control

Flow control chambers are specified to restrict the flow of the surface water into Blacup Beck at the agreed discharge rate. The flow control chamber features 1no. Hydro-Brake.

The unit reference for the Hydro-Brake flow control is as follows:

- SHE-0196-2500-2560-2500

Refer to Appendix C for details of the Hydro-Brake.

Prior to the adoption handover, the maintenance requirements for the Hydro-Brake are as follows:

- Normally little maintenance of the Hydro-Brake is required as there are no moving parts. Hydro-Brake flow controls are fitted with a pivoting bypass door which allows the chamber to be drained down should blockages occur.
- Following the installation of the Hydro-Brake, it is vitally important that any extraneous material, i.e. building materials, are removed from the unit and drainage system.

Maintenance Regime	Required Action	Typical Frequency
Regular Maintenance	Inspection and removal of litter / debris	Quarterly during construction, annually after
	Remove debris from the catchment surface where it might cause risk to performance.	6 Monthly
	Remove sediment from pre-treatment structures.	Annually or as required.
Occasional Maintenance	For blockages resulting in flooded manhole chambers, drain down manhole chamber via penstock and unlock	As required.
Remedial Maintenance	Inspect unit and hose down as required	After a large storm event during construction, annually after
	Inspect unit and replace as required. Neoprene seal shall be replaced at same time.	Annually

Monitoring	Inspect the penstock for workability. If sticking, will need greasing.	Annually
	Inspect for sediment build-up within the sump and remove if necessary. A Jet-Vac to be used to remove sediment build-up	Every 5 years or as required.

Yorkshire Water will be responsible for the maintenance of the flow control chamber and Hydro-Brake subject to the completion of a Section 104 agreement, therefore the flow control chamber will be constructed in accordance with Code for Adoption 2020.

For machinery required to enable overall maintenance, inspection and replacement of any elements of the flow control, the tanker access road shall be used from the adoptable highway.

CONTACT DETAILS AND RECORD OF MAINTENANCE

3.1 Contact Details of Individual Responsible for this Plan

In the event of concern over any matter related to SuDS, please contact:

Name	
Address	
Phone	
Email	

3.2 Record of Maintenance and Photographic Evidence

Please provide a record of all inspections (including all photographic evidence) below.

APPENDIX A – MAINTENANCE AND MANAGEMENT PLAN

Section 104 Agreement Plan (Drawing Ref: QD1776-17-01)

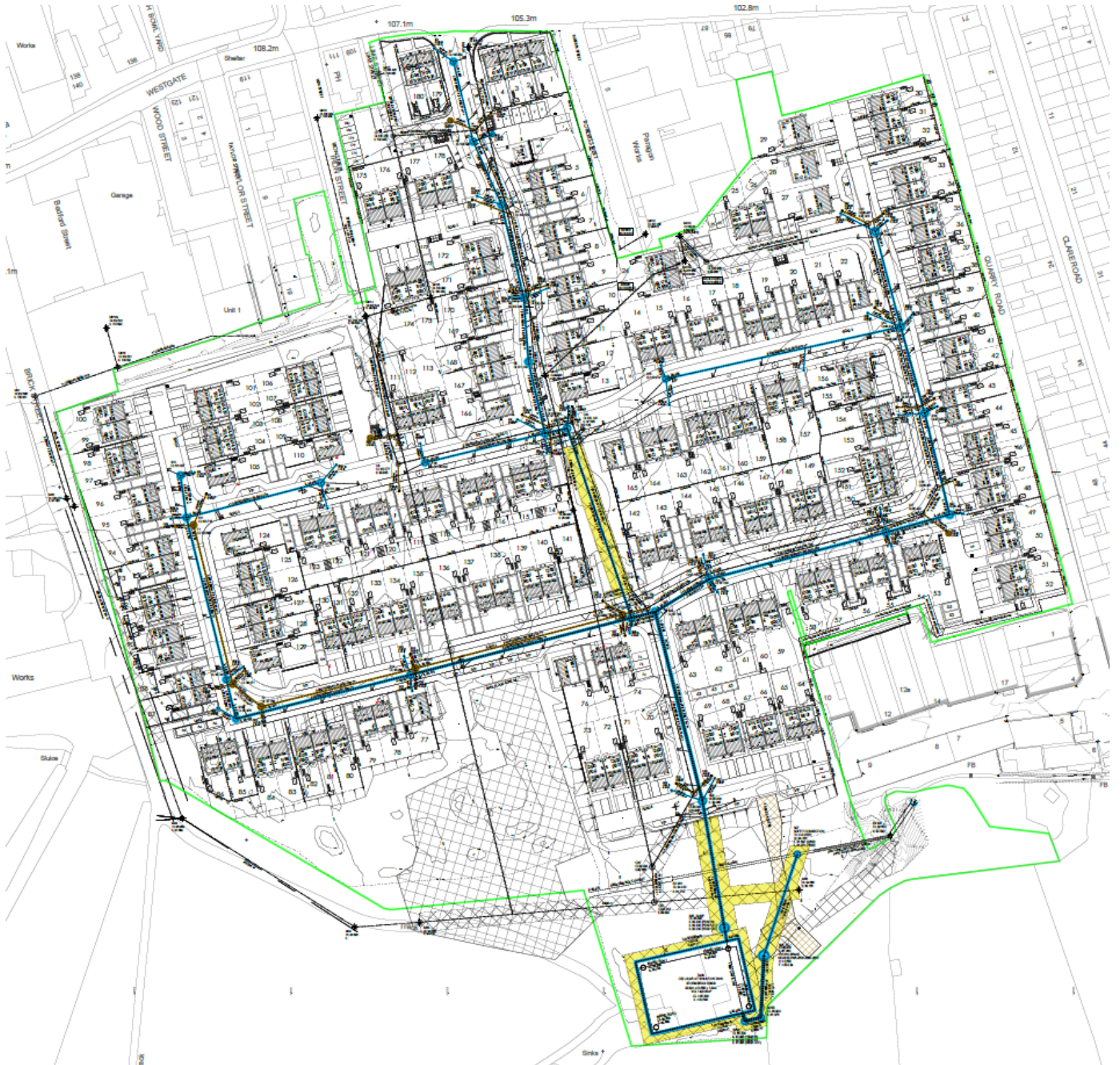

Section 185 Agreement Plan (Drawing Ref: QD1776-18-01)



APPENDIX B – CELLULAR ATTENUATION TANK STORMBRIXX HD900

ACO. we care for water



ACO StormBrixx SD, HD900 and HD

DATA SHEET

The ACO StormBrixx is a unique and patented plastic geocellular stormwater management system.

Its versatile design allows the system to be used in applications across all construction environments as a standalone solution or as part of an integrated Sustainable Drainage System (SuDS).

The range consists of StormBrixx SD (standard duty) and StormBrixx HD (heavy duty) stormwater management systems. StormBrixx SD is manufactured from recyclable polypropylene and has a design life of 50 years, whilst StormBrixx HD is manufactured from recycled polypropylene and has a design life of 60 years.

Benefits

- Fully certified performance - DIBt, MFPA, compliance with BS EN 17152-1
- Brick bonding and cross bonding for optimum stability
- Remote and man access for ease of maintenance
- High void ratio which minimises excavation volume (97% for SD and HD900, 95% for HD)
- Reduced CO₂ emissions



ACO StormBrixx SD, HD900 and HD

Simplified handling and logistics

- Compact delivery method with stackable nested design allowing up to four times fewer deliveries
- Unique stackable design that simplifies on site storage and handling during installation
- Time savings: movement on site and installation



The ACO StormBrixx Range



Complies with BS EN 17152-1

NEW – ACO StormBrixx HD900

Void ratio:	97%
Short term vertical compressive strength:	605kN/m ²
Short term lateral compressive strength:	120kN/m ²
Accessibility:	Remote access
One layer height:	920mm

Product Code	Description	Length [mm]	Width [mm]	Height [mm]	Weight [kg/m ²]
--------------	-------------	-------------	------------	-------------	-----------------------------

Components overview - dimensions and weights

314154	Half Body	1208	604	460/496	12.3
314091	Side Panel	907	592	104	3.13
314092	Top Cover	550	550	45	0.76
314094	Half Layer Cover Plate	1200	600	94	3.66
314098	Half Layer Side Panel	450	592	104	1.5



ACO StormBrixx HD

Void ratio:	95%
Short term vertical compressive strength:	455kN/m ²
Short term lateral compressive strength:	95kN/m ²
Accessibility:	Man access & remote access
One layer height:	612mm

Product Code	Description	Length [mm]	Width [mm]	Height [mm]	Weight [kg/m ²]
--------------	-------------	-------------	------------	-------------	-----------------------------

Components overview - dimensions and weights

314061	Half Body GF	1205	602	306/343	10
314021	Side Panel	580	580	35	1.6
314022	Top Cover	550	550	43	0.8

Access - HD



ACO StormBrixx man access specification and design process

Manufactured from reinforced concrete, each man access unit is 1200mm x 1200mm and is available in two heights; 610mm and 1210mm. Connections for 300mm through to 900mm pipes can be added along with inspection windows on 1, 2 or 3 sides of the chamber. Please specify when ordering the product.



Entrance via the Remote Access Unit

This unit is only suitable for the ACO StormBrixx HD. Access can be gained to the ACO StormBrixx HD unit using the Remote Access Unit as well as the Access Plate. These units can be installed both within the structure and on the outer edges. They replace the ACO StormBrixx layers and when all four walls are removed, full access to the system can be achieved.

For multi-layer systems, the units simply stack on top of each other and as shown clip in with the ACO StormBrixx units.

Each access chamber can be cut out as required by local conditions to accommodate various sizes of pipe (Ø110, 160, 200, 315, 400). (Use a drill to get the saw blade inserted when creating the openings in the lower shaft section.)

The access chamber are extended to the surface using the ACO Combi-point shafts or by using a 450dia twinwall pipe cut to suit.



Only usable with ACO StormBrixx HD

S25 - SUMP MANHOLE

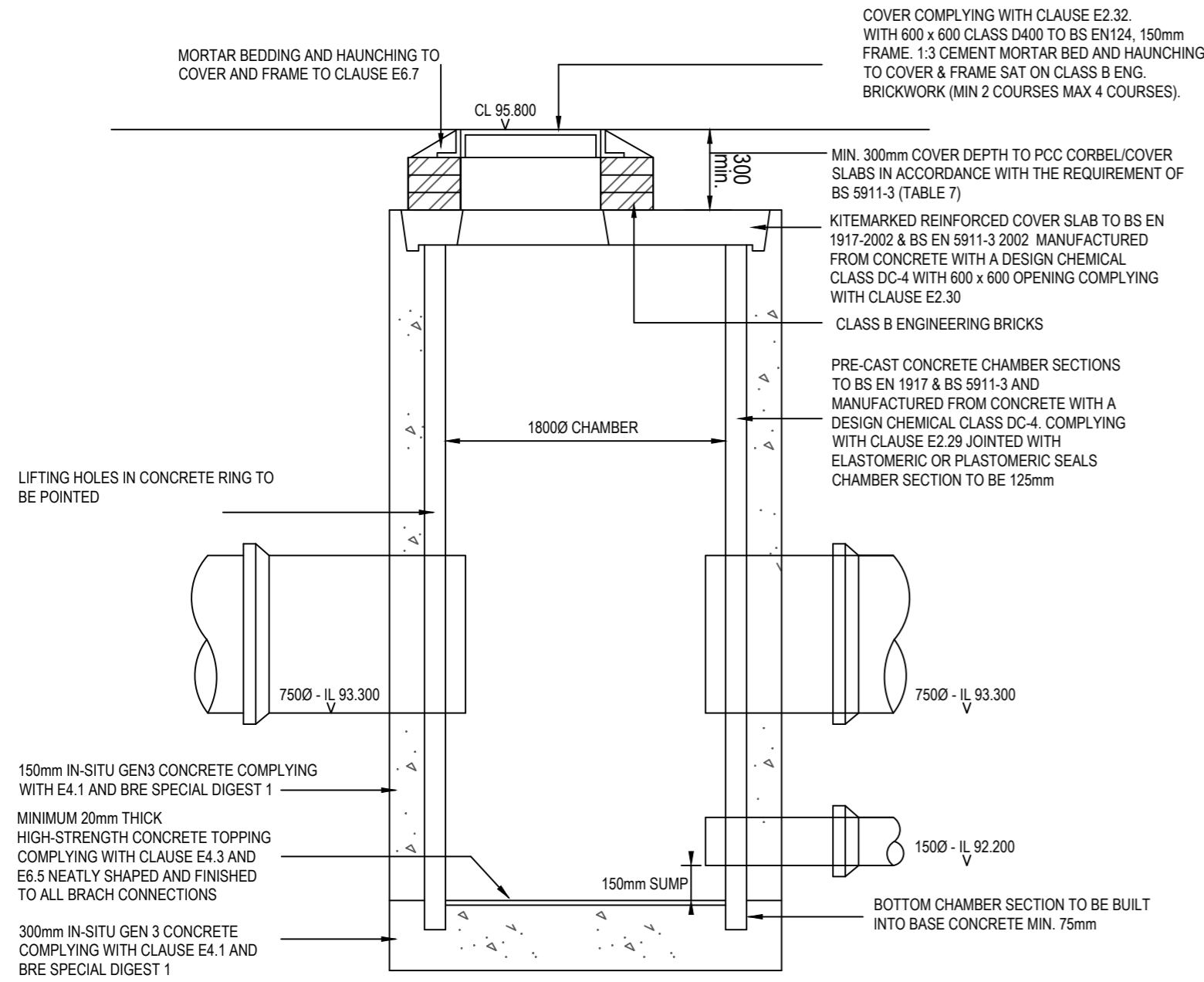

JOINT TO BE AS CLOSE AS POSSIBLE
TO FACE OF MANHOLE TO PERMIT
SATISFACTORY JOINT AND
SUBSEQUENT MOVEMENT

PIPE DIA. mm	ROCKER PIPE LENGTH mm
150-450	0.50-0.75
451-750	0.75-1.00
>750	SEEK GUIDANCE

SEE FIGURES B.13 AND CLAUSE E6.62
FOR ROCKER PIPE DETAILS

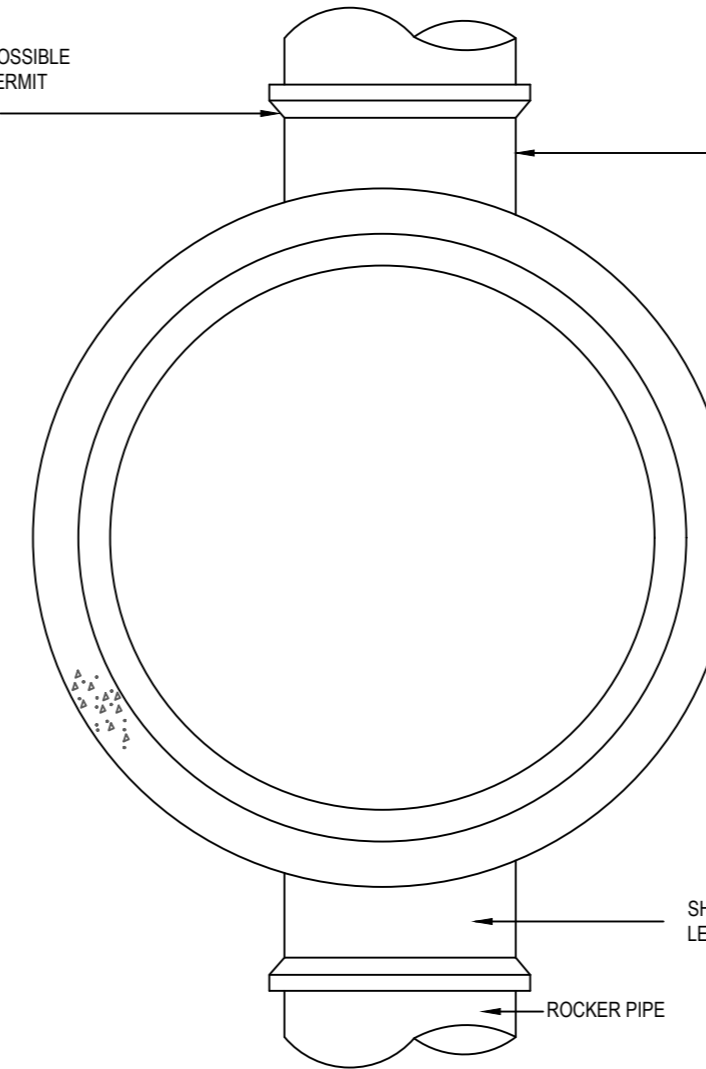

Only PDF/ DWG issues of this drawing are controlled. All other formats (eg. DWG AutoCAD FILES) are UN-controlled and are used at your own risk.

GENERAL NOTES:

- DO NOT USE THIS DRAWING IN ISOLATION. THIS DRAWING HAS BEEN PREPARED AS PART OF A SET, AND MUST THEREFORE BE READ IN CONJUNCTION WITH ALL OTHER DRAWINGS. ANY DISCREPANCIES MUST BE REPORTED TO THE ENGINEER PRIOR TO COMMENCING WORKS.
- THIRD PARTY INFORMATION IS USED TO PREPARE THE ENGINEERING DESIGN (INCLUDING ARCHITECTURAL LAYOUT, GROUND INVESTIGATION, EXISTING UTILITIES RECORDS, AND SPECIALIST DESIGN ITEMS). THE ENGINEERING DESIGN MUST THEREFORE BE READ IN CONJUNCTION WITH ALL THIRD PARTY INFORMATION PRIOR TO COMMENCING WORK. QUEENSBERRY DESIGN LTD ARE NOT RESPONSIBLE FOR ANY THIRD PARTY INFORMATION OR DETAILS.
- DRAWING STATUS WILL REMAIN PRELIMINARY UNTIL FULL TECHNICAL APPROVAL IS RECEIVED FROM LOCAL AUTHORITY AND SEWERAGE UNDERTAKER. WORKS COMMENCED PRIOR TO TECHNICAL APPROVAL ARE DONE SO AT RISK AND MAY BE SUBJECT TO CHANGE.
- THE CONTRACTOR IS EXPECTED TO PREPARE APPROPRIATE CONSTRUCTION METHOD STATEMENTS FOR ALL ASPECTS OF APPOINTED WORK. THIS SHOULD INCLUDE ANY TEMPORARY PROTECTION / WORKS.
- LAND DRAINAGE IS NOT PERMITTED TO DISCHARGE INTO THE PUBLIC SEWER NETWORK. ANY NEED FOR LAND DRAINAGE SHOULD BE ASSESSED BY THE GROUND WORKER AND LANDSCAPER DURING CONSTRUCTION AND PLACEMENT OF GARDENS ON AN INDIVIDUAL PLOT BASIS. IF LAND DRAINAGE DESIGNS ARE REQUIRED, THEY SHOULD BE APPOINTED PRIOR TO PLOT COMPLETION.
- THE CONTRACTOR IS EXPECTED TO CROSS CHECK ALL DRAINAGE INVERTS PRIOR TO COMMENCING WORK. THIS MAY INVOLVE COMPLETION OF TRIAL HOLES IF INVERT LEVELS HAVE BEEN INTERPOLATED. THE POSITION, LINE AND DIAMETER OF ALL EXISTING DRAINAGE APPARATUS SHOULD BE CONFIRMED ON SITE PRIOR TO THE COMMENCEMENT OF THE WORKS. ANY DISCREPANCIES MUST BE REPORTED TO THE ENGINEER IMMEDIATELY.
- THE CONTRACTOR MUST MONITOR THE 'AS BUILT' PROGRESS OF EACH CONSTRUCTION STAGE (ROADS/SEWERS/PLOT WORKS ETC), TO ENABLE THE NEXT STAGES OF CONSTRUCTION TO BE CHECKED BEFORE INSTALLATION.

HIGHWAYS

- ALL HIGHWAY WORKS TO BE CARRIED OUT IN ACCORDANCE WITH THE CURRENT LOCAL AUTHORITY DESIGN GUIDE AND SPECIFICATION.
- ALL EXCAVATIONS BELOW PROPOSED AND EXISTING HIGHWAYS TO BE BACK FILLED WITH GRANULAR TYPE 1 SUB-BASE AND WELL COMPACTED IN LAYERS NOT EXCEEDING 150MM, UNLESS OTHERWISE AGREED.
- HIGHWAY AUTHORITY TO BE NOTIFIED BY THE CONTRACTOR PRIOR TO THE COMMENCEMENT OF WORKS.

ADOPTABLE DRAINAGE

- ALL ADOPTABLE SEWER WORKS AND MATERIAL TO BE IN ACCORDANCE WITH CODE FOR ADOPTION, THE RELEVANT BRITISH EUROPEAN AND YORKSHIRE WATERS STANDARDS/REQUIREMENTS/ADDENDUM TO THE MECHANICAL AND ELECTRICAL SPECIFICATION AND KITEMARKED.
- MANHOLE COVERS SHALL HAVE A CLEAR OPENING OF 600MM AND SHALL BE CLASS D400 TO BS EN 124 WITH 150MM DEEP FRAMES IN HIGHWAYS.
- FILLED GROUND MUST BE FILLED AND CONSOLIDATED UNDER THE SUPERVISION AND TO THE SATISFACTION OF YORKSHIRE WATER BEFORE ANY SEWER WORKS ARE CARRIED OUT.
- YORKSHIRE WATER IS NOT OBLIGED TO ACCEPT FILTER DRAIN AND DRAINAGE RUN-OFF INTO THE PUBLIC SEWER NETWORK OR ADOPTABLE DRAINAGE SYSTEM (DIRECTLY OR INDIRECTLY). AN ALTERNATIVE METHOD OF DISPOSAL OF THE LAND DRAINAGE RUN-OFF WILL THEREFORE BE REQUIRED AND YOU WILL HAVE TO AGREE WITH THE LOCAL AUTHORITY LAND DRAINAGE SECTION REGARDING THE DISPOSAL OF THE FILTER DRAIN AND DRAINAGE RUN-OFF.
- THE ADOPTABLE SEWERS SHOULD BE A MINIMUM OF 1M AND MANHOLES 0.5M FROM KERB FACES AND SERVICE MARGINS.
- SEWERS MUST HAVE 5 METRES CLEARANCE FROM TREES AND HEDGES OR THE WIDTH OF THE CANOPY AT MATURE HEIGHT.
- SEWERS TO BE LAID IN CLASS 'S' BEDDING (150MM GRANULAR BED AND SURROUND), WHERE DEPTH OF COVER TO TOP OF THE SEWER IS LESS THAN 1.2M IN HIGHWAYS AND VERGES (OR LESS THAN 900MM IN NON-VEHICULAR ACCESS AREAS) THEN A CONCRETE SLAB SHOULD BE PROVIDED ABOVE GRANULAR BED AND SURROUND.
- BEDDING AND BACKFILL MATERIAL TO CONFORM TO THE REQUIREMENT OF WATER INDUSTRY SPECIFICATION 4-08-02 (TABLE A2).
- YORKSHIRE WATER POLICY IS THAT TYPE 'C' BRICK MANHOLES AND 1000MM DIAMETER MANHOLE RINGS ARE NOT PREFERRED. INSTEAD, IT IS PREFERRED THAT YOU USE A TYPE 'B' MANHOLE WITH 1200MM DIAMETER OR 1500MM DIAMETER RINGS, WITH THE OPENING SITED OVER THE CHANNEL WHERE DEPTH OF COVER TO PIPE SOFFIT IS 1 - 1.5M.
- ADOPTABLE PLASTIC SEWER PIPES TO BE KITEMARKED CERTIFIED TO WIS 4-35-01 AND BS EN 13476. ADOPTABLE PLASTIC SEWER PIPES TO BE LAID IN MAXIMUM 3 METRE LENGTHS UNLESS THERE IS A SPECIFIC OPERATIONAL NEED TO LAY LONGER LENGTHS. PLASTIC CHANNEL SECTIONS IN MANHOLES ARE NOT ACCEPTABLE AND YORKSHIRE WATER WOULD REQUIRE CLAY WARE CHANNEL IN MANHOLES.
- THE MINIMUM CRUSHING STRENGTH FOR CLAY PIPES SHOULD BE AS FOLLOWS: 100MM DIA. 40KNM, 150MM DIA. 40KNM, 225MM DIA. 40KNM AND 300MM DIA. 20KNM. THE MINIMUM CRUSHING STRENGTH FOR CONCRETE PIPES SHOULD BE: (CLASS 120 TO EN 1916/BS5911-1 2002). PLASTIC PIPES SHOULD CONFORM TO WIS 4-35-01 AND BS EN 13476.
- WHERE A 1/25 COVER AND FRAME HAS BEEN APPROVED, THIS MUST NOT BE COATED IN PLASTIC AND MUST HAVE LIFTING EYES SUITABLY SIZED TO ACCOMMODATE STANDARD LIFTING KEYS. SCREW DOWN COVERS ARE NOT ACCEPTABLE.
- THERE MUST BE ENOUGH CLEARANCE AT CROSSOVERS TO ACCOMMODATE BEDDING TO BOTH PIPES, APPROX. 300MM. IF CROSSOVER IS NEAR THE ROCKER THEN THE CLEARANCE NEEDED MAY NEED TO BE INCREASED.

DRAINAGE WITHIN HIGHWAY REQUIREMENTS

- ALL ADOPTABLE SEWER WORKS AND MATERIALS TO BE IN ACCORDANCE WITH CODE FOR ADOPTION AND NATIONAL SPECIFICATION DESIGN MANUAL FOR ROADS AND BRIDGES.
- ALL PCC UNITS IN OVERSIZE MANHOLES MUST HAVE A DESIGN WORKING LIFE OF 100 YEARS (MIN) IN ACCORDANCE WITH BS 8500-1:2015-A2:2019-TABLE A5.
- PRECAST CONCRETE MANHOLE UNITS INCLUDING THEIR PCC COVER SLABS SHALL COMPLY WITH THE RELEVANT PROVISIONS OF BS EN 1917 AND BS 5911-3 AND SHALL BE MANUFACTURED FROM CONCRETE WITH A DESIGN CHEMICAL CLASS DC-4 UNLESS SATISFACTORY EVIDENCE THROUGH SOIL ANALYSIS CAN BE PROVIDED THAT A LOWER CLASS WILL RESIST ATTACK FROM SOILS AND GROUND WATER.
- PRECAST CONCRETE CORBEL SLABS SHALL COMPLY WITH BS 5911-3 TABLE 3 AND FIGURE 8.
- COVER SLABS SHALL BE INSTALLED WITH A MINIMUM OF 300mm COVER TO FINISHED GROUND LEVEL.
- SUBMISSION OF A CONSTRUCTION COMPLIANCE CERTIFICATE SHALL BE PROVIDED UPON COMPLETION OF DRAINAGE WORKS.

EXISTING SERVICES

PRIOR TO THE COMMENCEMENT OF ANY WORKS UNDER GROUND MAPPING SURVEYS AND CONSTRAINTS PLAN IS TO BE REFERRED TO ANY DISCREPANCIES ARE TO BE REPORTED TO ENGINEER.

ANY EXISTING SERVICES WHICH MAY BE AFFECTED BY THE PROPOSED WORKS SHOULD BE LOCATED BY MEANS OF A HAND DIG IN CLOSE LAISON WITH THE STATUTORY SERVICE AUTHORITIES. THE CONTRACTOR SHALL INFORM THE DEVELOPER OF ANY SERVICES THAT MAY AFFECT THE PROPOSED DESIGN. CONTRACTOR TO NOTIFY STATUTORY SERVICE AUTHORITIES PRIOR TO COMMENCEMENT OF WORK. AS CONSTRUCTED INFORMATION IT IS THE CONTRACTORS RESPONSIBILITY TO PROVIDE THE FOLLOWING AS CONSTRUCTED DRAWINGS TO THE DEVELOPER UPON THE COMPLETION OF THE WORKS COVERED BY THE CONTRACT -

- POSITION AND COORDINATES OF ALL ADOPTABLE MANHOLES.
- INVERT AND COVER LEVELS OF ALL ADOPTABLE MANHOLES.
- NEW GULLY POSITIONS AND CONNECTIONS.
- POSITION AND DEPTH OF SERVICE DUCTS FOR WATER, GAS, ELECTRIC, BT, CABLE AND STREET LIGHTING, STATING SIZE AND NUMBER OF DUCTS.

Rev.	Date	Revision Details	Drawn	Checked
C	19.11.25	STEP RUNGS REMOVED FROM PLAN	CW	ND
B	20.06.25	CONSTRUCTION ISSUE	CW	ND
A	05.08.24	STEP IRONS REMOVED - COVER OPENING CHANGED TO 600 x 600	ND	ND

© This drawing is the property of Queensberry Design Limited and the information can only be reproduced with their prior permission.

QUEENSBERRY DESIGN
CIVIL, STRUCTURAL, ARCHITECTURAL
& GEOTECHNICAL CONSULTANTS

NORTH EAST OFFICE
5 STAITHES, THE WATERMARK, GATESHEAD,
TYNE AND WEAR NE11 5SN
T: 0191 460 9090
NORTH WEST & YORKSHIRE OFFICE
Suite 12a, Brookfield Court, Selby Road, Leeds,
LS25 1NB
A: 0113 517 7099
www.queensberrydesign.co.uk

Client	STRATA		
Project	WESTGATE CLECKHEATON		
Title	MANHOLE S25		
Drawn	FA	Checked	ND
Date	22.07.2024		
Drawing Number	QD1776-08-05		
Drawing Status	CONSTRUCTION	Scale	1:25 - A2
Rev.	C		

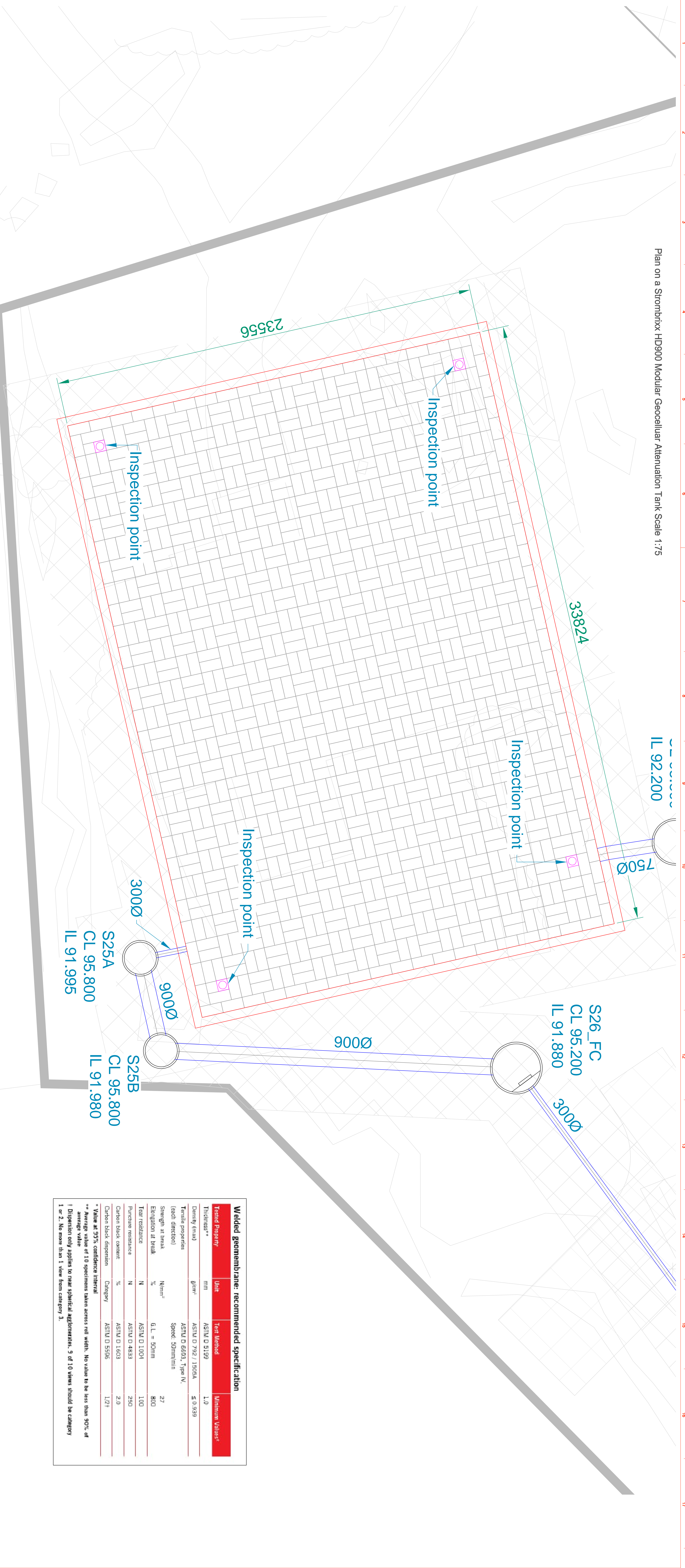

Inlet Access, Maintenance and Low Flow Channel Details
Scale 1:50

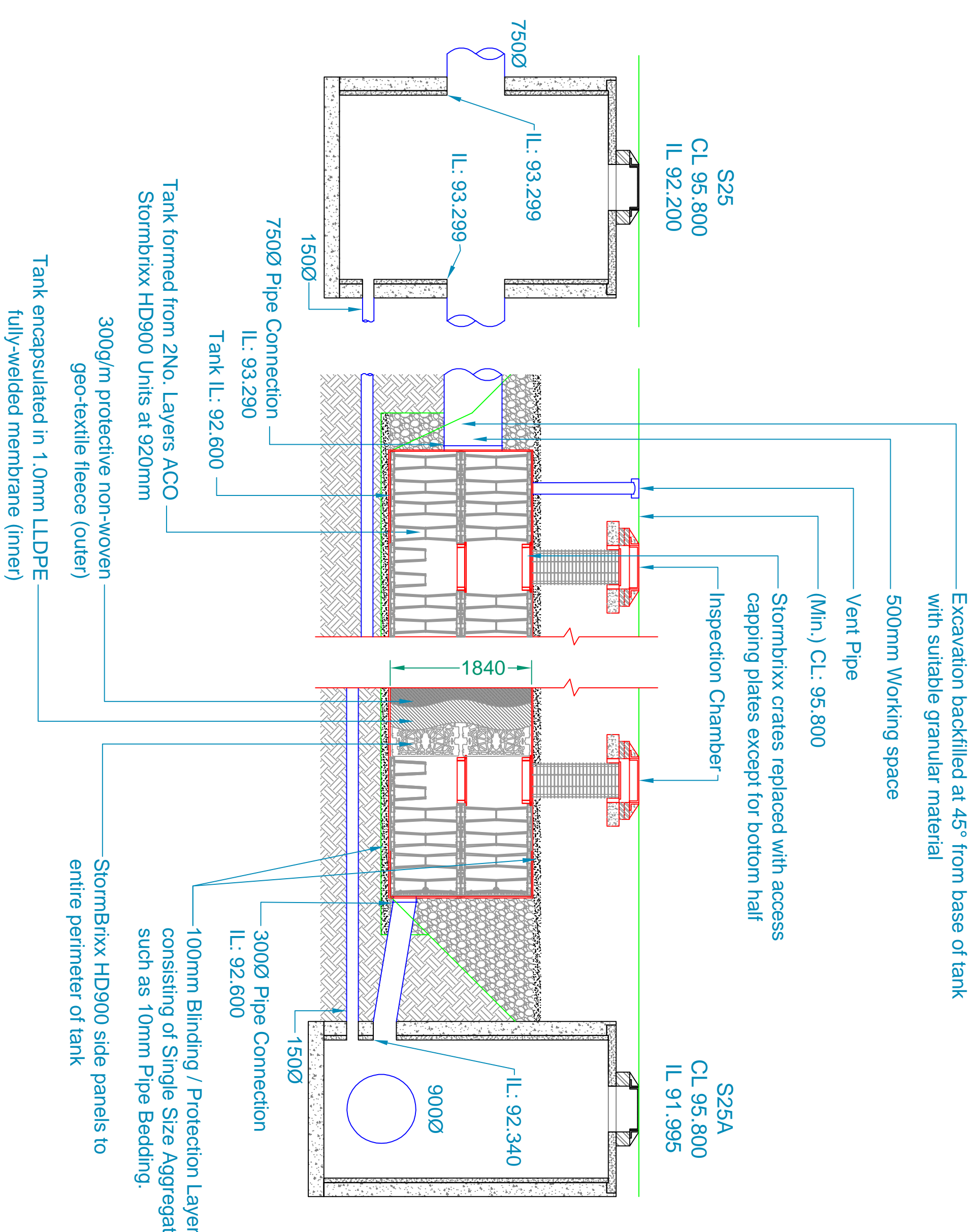

Welded geomembrane: recommended specification

Tested Property	Unit	Test Method	Minimum Values*
Thickness**	mm	ASTM D 5199	1.0
Density (final)	g/cm ³	ASTM D 792 / 1505A	≥ 0.939
Tensile properties (each direction)		ASTM D 6603, Type IV, Speed: 50mm/min	
Strength at break	N/mm ²	G.L. = 50mm	27
Elongation at break	%	ASTM D 1004	100
Tear resistance	N	ASTM D 4833	250
Puncture resistance	N	ASTM D 1603	2.0
Carbon black dispersion	Category	ASTM D 5506	1/2†

** Value at 95% confidence interval
 † Average value of 10 specimens taken across roll width. No value to be less than 90% of average value
 ‡ Dispersion only applies to neat spherical agglomeration, 9 of 10 views should be category 1 or 2. No more than 1 view from category 3.

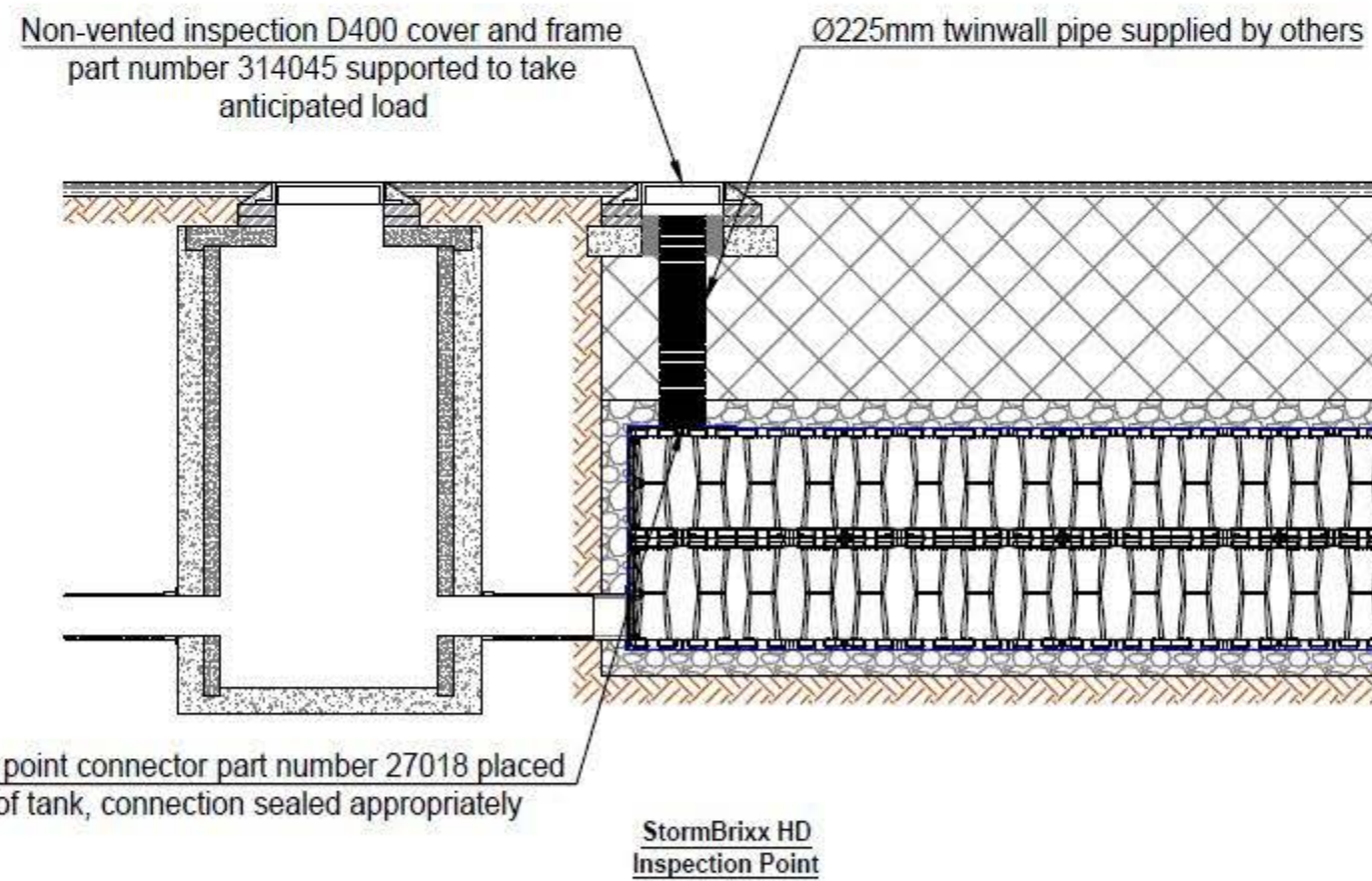

	Version	Date	Discussions	Revised
		400 Millipore Plus Stormbrix Ltd 2077751, Ltd www.aco.com	09/07/2024 Prepared by: SDA	09/07/2024 Drawn by: SDA
ACO Technologies plc 2077751, Ltd www.aco.com		Water Company Adoptable Standard Detail Stormbrix (HD900) Online Tank General Arrangement	Unit: mm Scale: 1:50	Form: A0 Sheet: 1 of 1

Access Configurations



Minimum cover depths ⁽¹⁾ over the top of ACO StormBrixx		
Location	HD ⁽²⁾	SD
Non-Trafficked areas i.e landscaping	0.5 ⁽³⁾	Consult ACO
Car parks, vehicles up to 2500kg gross mass	0.6	Consult ACO
Car parks, occasional vehicles greater than 2500kg ⁽⁴⁾ mass	0.75	Consult ACO
Occasional HGV traffic up to 44000kg GVW (HA loading)	Consult ACO	Consult ACO

- (1) Assumed 27° load distribution angle through fill material and overlaying surface asphalt or block paving
- (2) Please check minimum frost check cover depths for geographical location
- (3) Minimum cover depth to avoid accidental damage from gardening/landscaping work
- (4) Occasional trafficking by refuse collection or similar vehicles (typically one per week)

A	25/10/17	Initial Issue	P.J
Version	Date	Description	Name
 ACO Technologies plc		ACO Business Park Hitchin Road Shefford Bedfordshire SG17 5TE, UK Tel: 01462 816666 www.aco.co.uk	Drawing Number: 23768 Title:
		ACO StormBrixx Typical Access Detail Installation Detail Drawing	
Created by: P.J	Released by: L.D	Projection: ISO-A 	Units: mm
Created at: 25/10/17	Released at: 25/10/17	Information contained in this drawing is copyright property of ACO Technologies plc. Any reproduction in part or whole without written permission of ACO Technologies plc is prohibited	
Replacement for:	Replaced by:	Format: A3	Scale: 1:5
-	-	Sheet: 1 of 1	

APPENDIX C – FLOW CONTROL DETAILS

HYDRO-BRAKE: SHE-0190-2500-3000-2500

Technical Specification		
Control Point	Head (m)	Flow (l/s)
Primary Design	2.560	25.000
Flush-Flo™	0.743	24.967
Kick-Flo®	1.548	19.650
Mean Flow		21.835





hydro-int.com/patents

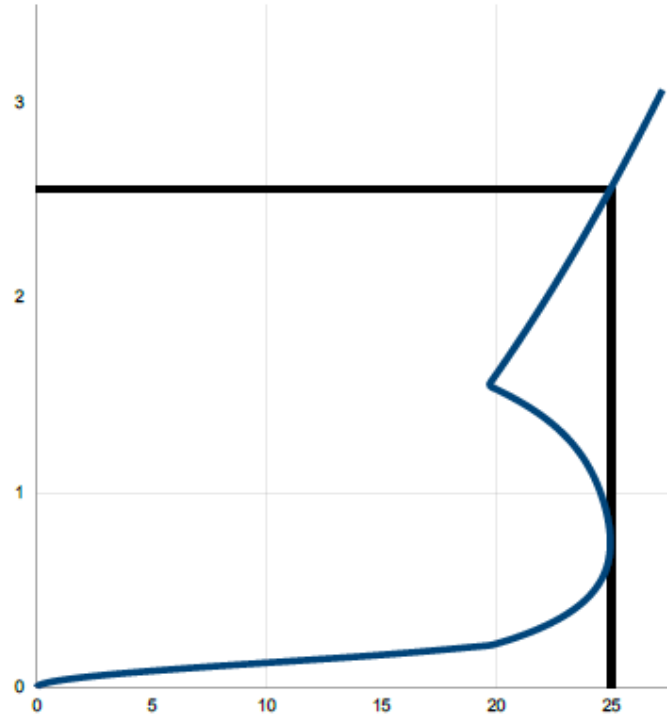

Head (m)	Flow (l/s)
0.000	0.000
0.088	5.453
0.177	16.068
0.265	21.082
0.353	22.754
0.441	23.818
0.530	24.464
0.618	24.815
0.706	24.955
0.794	24.947
0.883	24.831
0.971	24.627
1.059	24.339
1.148	23.950
1.236	23.426
1.324	22.718
1.412	21.767
1.501	20.508
1.589	19.898
1.677	20.416
1.766	20.921
1.854	21.413
1.942	21.893
2.030	22.362
2.119	22.821
2.207	23.270
2.295	23.710
2.383	24.142
2.472	24.565
2.560	24.981

DESIGN ADVICE	The head/flow characteristics of this SHE-0196-2500-2560-2500 Hydro-Brake® Optimum Flow Control are unique. Dynamic hydraulic modelling evaluates the full head/flow characteristic curve. ! The use of any other flow control will invalidate any design based on this data and could constitute a flood risk.	
DATE	19/03/2024 15:03	SHE-0196-2500-2560-2500 Hydro-Brake® Optimum
Site	cleckheaton	
DESIGNER	Nick Dunwoodie	
Ref	s26	

© 2023 Hydro International, Rivermead Court, Kenn Business Park, Windmill Road, Kenn, Clevedon, BS21 6FT. Tel 01275 878371 Fax 01275 874879 Web www.hydro-int.com Email designtools@hydro-int.com

Technical Specification		
Control Point	Head (m)	Flow (l/s)
Primary Design	2.560	25.000
Flush-Flo™	0.743	24.967
Kick-Flo®	1.548	19.650
Mean Flow		21.835

hydro-int.com/patents

Hydro-Brake® Optimum Flow Control including:

- 5 mm grade 304L stainless steel
- Integral stainless steel pivoting by-pass door allowing clear line of sight through to outlet, c/w stainless steel operating rope
- Beed blasted finish to maximise corrosion resistance
- Stainless steel fixings
- Rubber gasket to seal outlet
- Indicative Weight: 110 kg

IMPORTANT: ○ LIMIT OF HYDRO INTERNATIONAL SUPPLY
 THE DEVICE WILL BE HANDED TO SUIT SITE CONDITIONS
 FOR SITE SPECIFIC DETAILS AND MINIMUM CHAMBER SIZE REFER TO HYDRO INTERNATIONAL
 ALL CIVIL AND INSTALLATION WORK BY OTHERS
 * WHERE SUPPLIED
 HYDRO-BRAKE® FLOW CONTROL & HYDRO-BRAKE® OPTIMUM FLOW CONTROL ARE REGISTERED TRADEMARKS FOR FLOW CONTROLS DESIGNED AND MANUFACTURED EXCLUSIVELY BY HYDRO INTERNATIONAL

THIS DESIGN LAYOUT IS FOR ILLUSTRATIVE PURPOSES ONLY. NOT TO SCALE.

DESIGN ADVICE 	The head/flow characteristics of this SHE-0196-2500-2560-2500 Hydro-Brake® Optimum Flow Control are unique. Dynamic hydraulic modelling evaluates the full head/flow characteristic curve. The use of any other flow control will invalidate any design based on this data and could constitute a flood risk.	<p>A CRN COMPANY</p>	
	DATE: 19/03/2024 15:03		SHE-0196-2500-2560-2500 Hydro-Brake® Optimum
	SITE: cleckheaton		
	DESIGNER: Nick Dunwoodie		
REF: s26			

© 2024 Hydro International Ltd • Unit 2, Riverside Court • Kern Business Park • Windmill Road • Kern • Clevedon • B521 6PT • Tel: 01275 878371 • www.hydro-int.com • Email: Enquiries@hydro-int.com

APPENDIX D – ACO STORMBRIXX MAINTENANCE AND INSPECTION MANUAL



ACO StormBrixx SD and HD

MAINTENANCE AND INSPECTION MANUAL



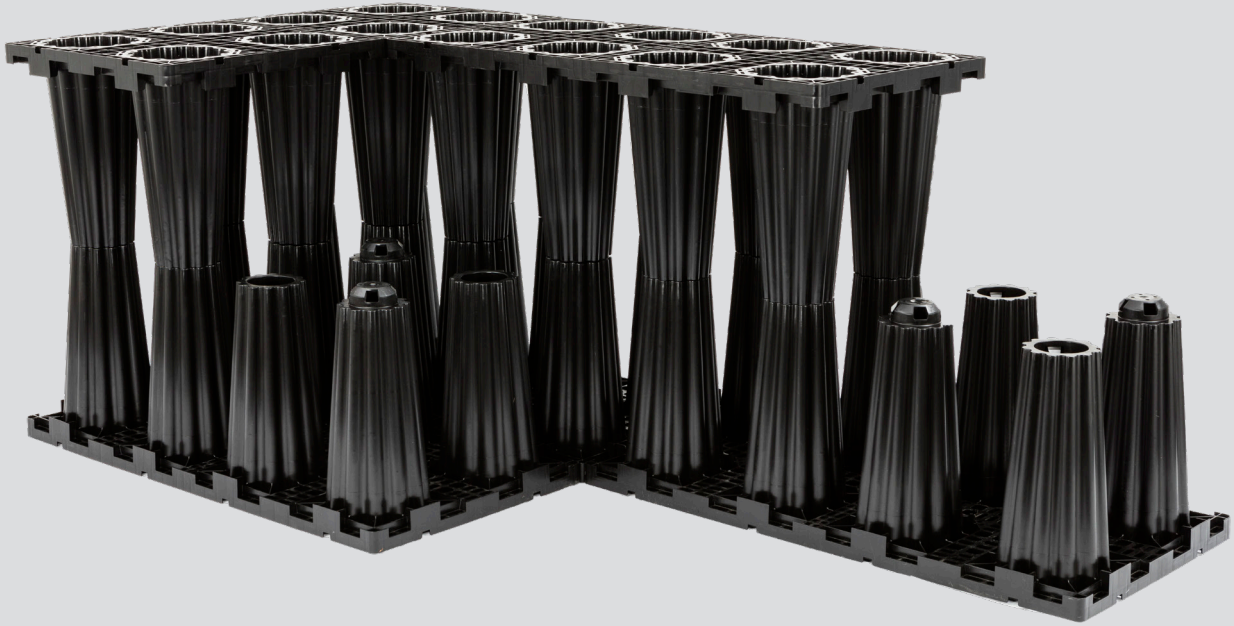

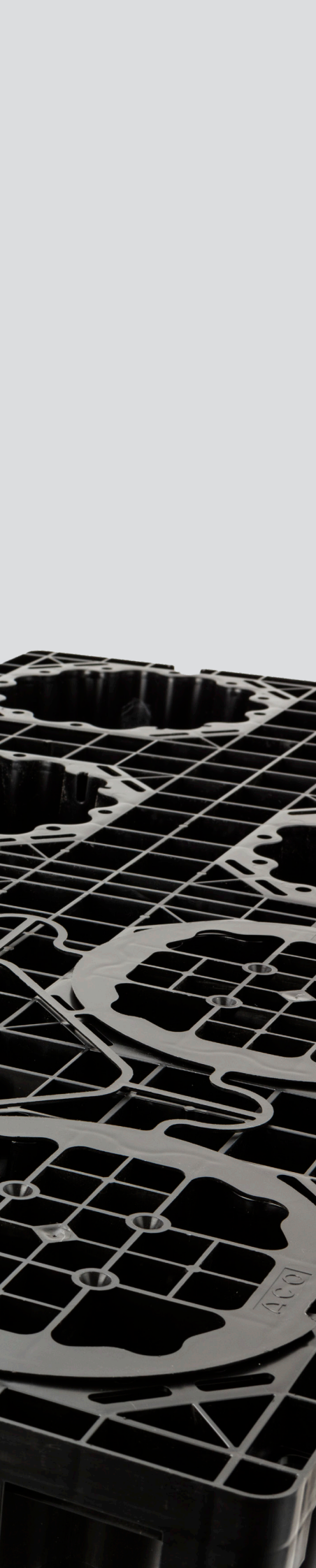

Contents

Information for operators	4
Visual inspection, maintenance and cleaning of ACO StormBrixx	5
Inspection and maintenance access	7
Manholes	9
Inspection via different access points	10
Access Covers D 400	11

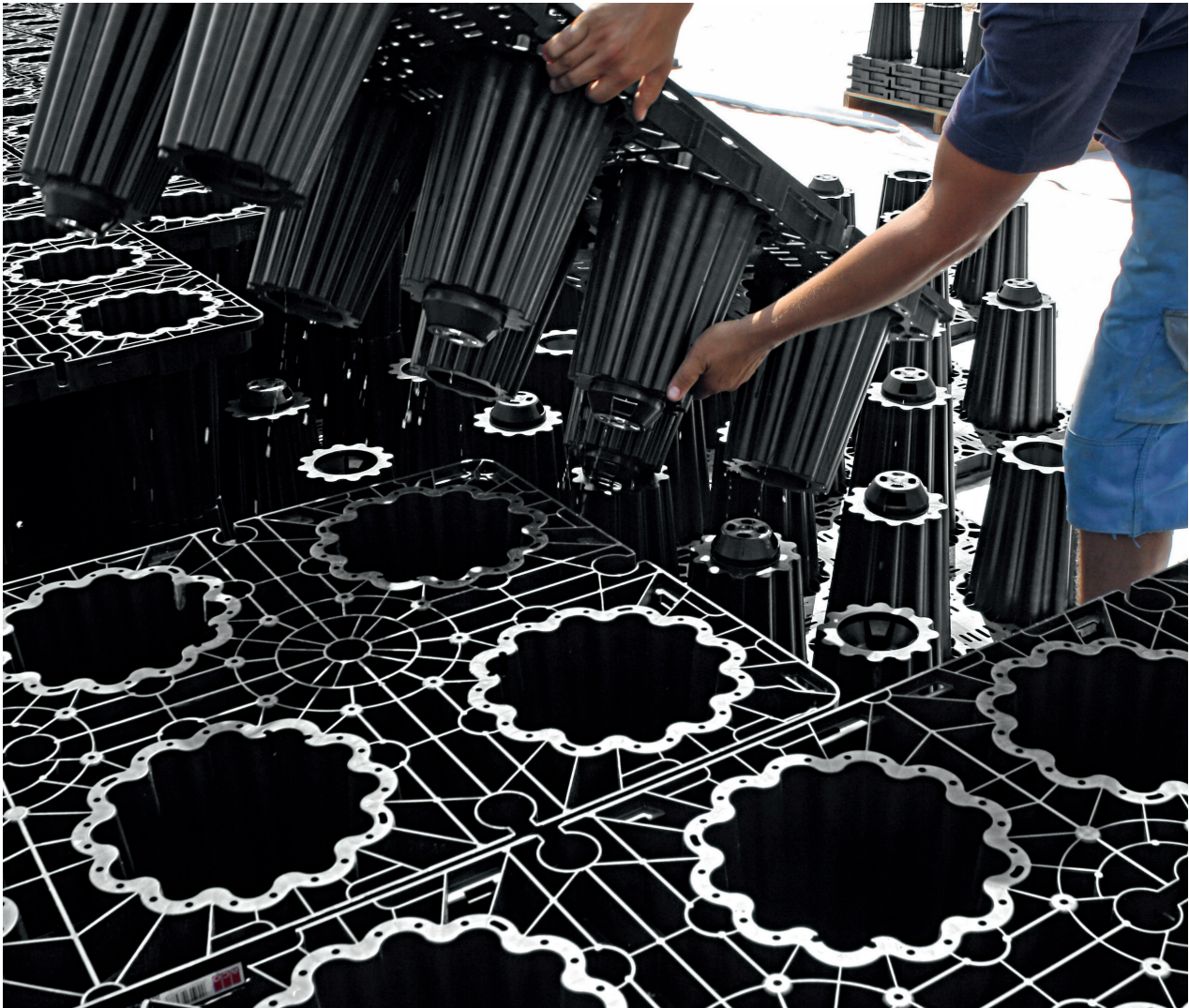

Information for operators

4

If the owner and the operator are not one and the same, then it is helpful to agree:

- Who is responsible for day-to-day operations?
- Who is responsible for initiating maintenance or repairs for the plant?
- Who will react when there is a malfunction?
- The operator is responsible for the siting (design and dimensions), installation and operation of the system.
- The owner has to ensure that that the operator or person responsible has a copy of the maintenance manual.

It is the responsibility of the operator to ensure the following points are respected:

- The system must only be used as intended and in a good operating condition.
- Maintenance timetables are adhered to and malfunctions dealt with swiftly.
- Only qualified and authorised staff are used.

Visual inspection, maintenance and cleaning of ACO StormBrixx

Thanks to the intelligent building block architecture of ACO StormBrixx, which requires easy-to-erect side panels to be installed to the external perimeter only, the total volume of the installation attenuation/infiltration system can be accessed for inspection and maintenance.

Maintenance work and requirements should be carefully considered during the planning/design phase. Access turrets, sediment tunnels/forebays, and low flow channels can all be incorporated into the StormBrixx system, but the number and combination of these details should be specified as early as possible. In addition to this, we recommend adhering to all the current relevant legal requirements.

During the construction phase, care must be taken to ensure that no sediment enters the inlet pipes, shafts and the infiltration system. At the construction phase an increase in the volume of sediment must be expected from the connected surfaces and must be counteracted.

Maintenance Fequency

The initial inspection/cleaning of the ACO infiltration system should take place after completion and before handover, so forming part of the commissioning of the installation. A visual inspection of the shafts and a camera passage through the pipes and the storage system is recommended. The results should be recorded in an operating logbook.

To guarantee long-term operability, the recommendations of the current relevant legal requirements must be respected.

A visual inspection should be carried out at least twice a year, preferably in the spring (high pollen levels) and autumn (falling leaves). If necessary, maintenance/cleaning should be undertaken.

The operator is responsible for ensuring that all maintenance work is carried out by qualified expert staff, who are fully aware of the maintenance and operating instructions. Relevant accident prevention regulations must be respected. The results of the inspections carried out can then be used to determine the frequency of maintenance interventions in future.

If unusual weather conditions occur (heavy rainfall or similar), additional inspections and/or maintenance are recommended.

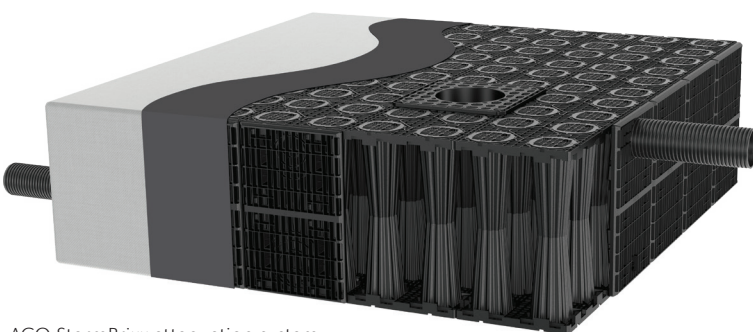

ACO StormBrixx attenuation system

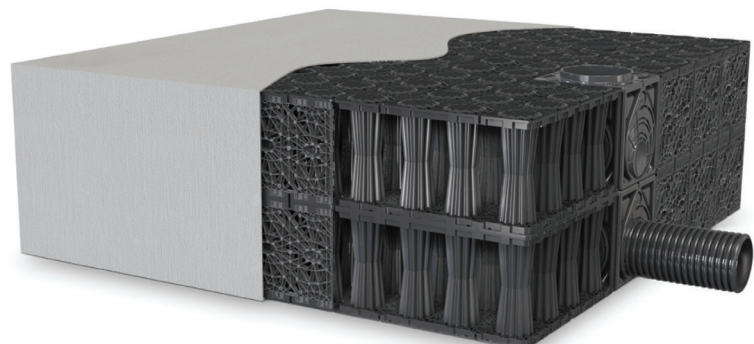

ACO StormBrixx infiltration system

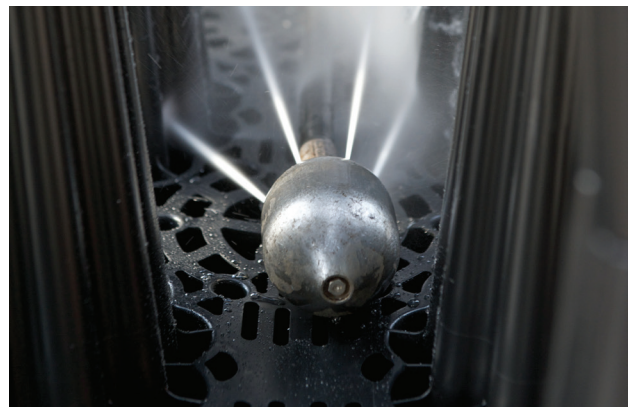
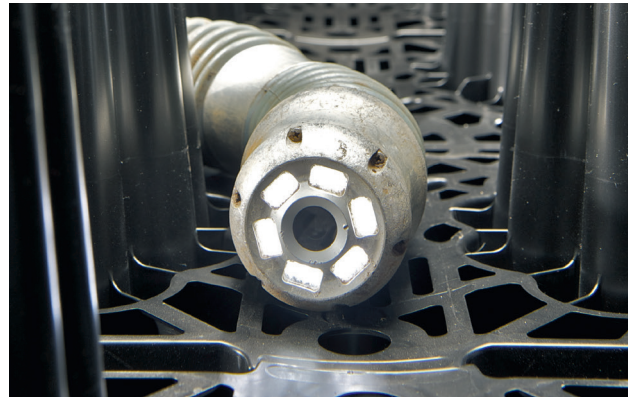

Camera and jetting nozzle

The inspection and cleaning access points, consisting of access chambers, intermediate sections and upper parts, provide an easy way for sewer cameras, jetting nozzles and jetting lances to access the ACO StormBrixx hollow block infiltration system.

Cleaning

The cleaning of the ACO StormBrixx infiltration system can, if necessary, be carried out using sewer cleaning equipment (sewer cleaning technology/high-pressure washing). The maximum water pressure must not exceed 100 bar.

The water can be sucked out through the upper, intermediate and lower shaft sections. When disposing of the cleaning water/sediment all applicable legal requirements must be observed.

Visual inspection

Visual inspection includes the following points:

- The condition of the infiltration space (side walls, bases, covers, columns)
- Connecting pipes

If there are signs of leakage, the water-tightness of the system must be re-established by suitable tests. If faults are detected during the visual inspection (dirt, distortions etc.) these must be corrected immediately.

Operating logbook

The results of the visual inspection and any maintenance and repair measures undertaken must be recorded in an operating logbook. These records then allow decisions to be made about the necessary frequency of future visual inspections and maintenance measures.

The following data and information must be recorded in the operating logbook:

- Date of visual inspection or maintenance work
- Identity of staff involved
- Problems arising (also causes of problems)
- Measures taken

Keeping a logbook has many benefits, e.g. traceability of sources of problems, targeted error analysis and determination of follow-up measures.

Warranty

Please refer to the relevant section in the general terms and conditions of sale of the ACO company in your country.

Inspection and maintenance access

Completely installed attenuation/infiltration system with ACO StormBrixx SD:

- Adapter for shaft construction (A) within the overall system
- Upper part (1)

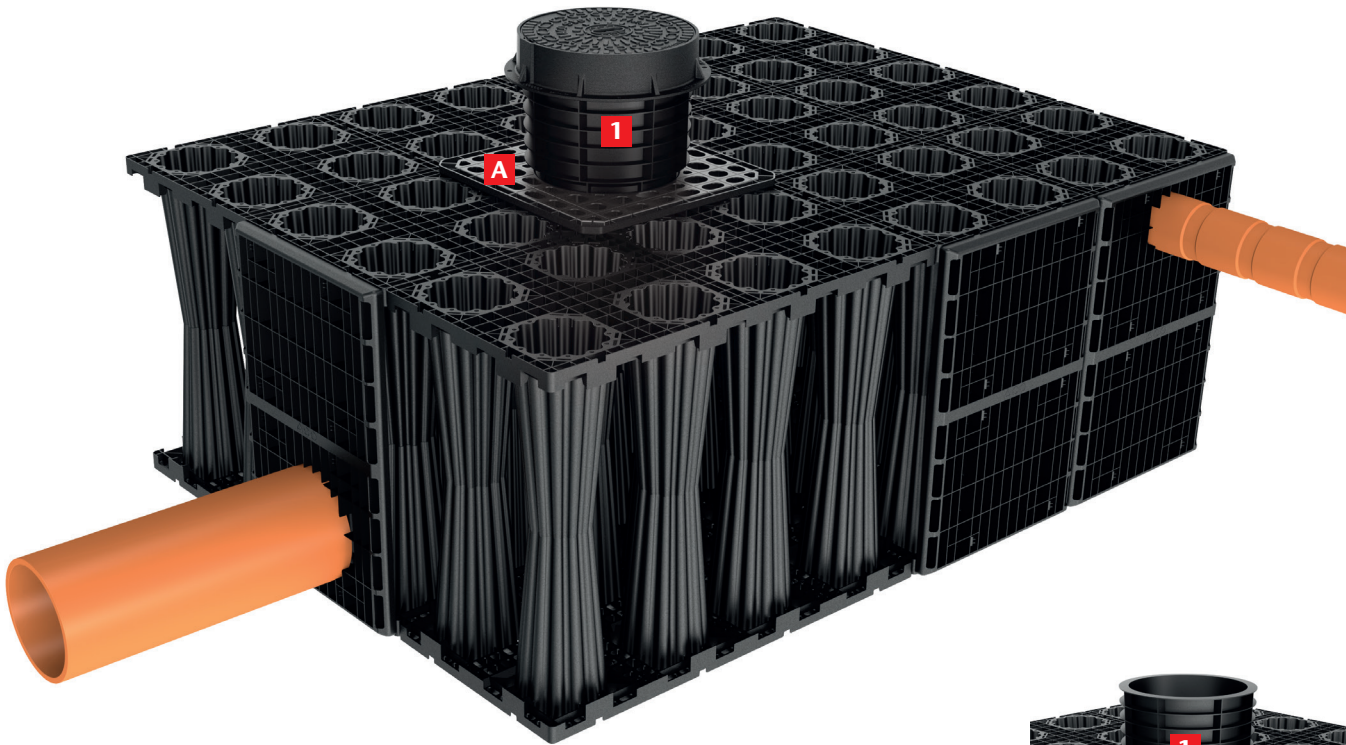

Entrance via access plate

The ACO StormBrixx Adapter for shaft construction (A) is installed as an inspection access **within the block attenuation/infiltration system**. An inspection shaft can thus be installed quickly and economically by simply assembling in the required place. The ACO StormBrixx upper parts (1) are added to the top of the access.



ACO StormBrixx SD:

The adapter for shaft construction (A) together with the ACO StormBrixx riser piece (1) is mounted within the overall system for inspection and cleaning of the system.

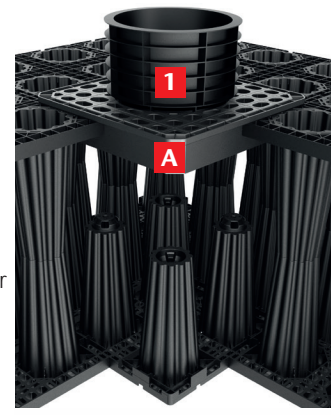

ACO StormBrixx HD:

If access points are required within the system, the adapter for shaft construction (A) can be used together with the upper part (1) as an alternative to the access chamber (B) - see page 8.

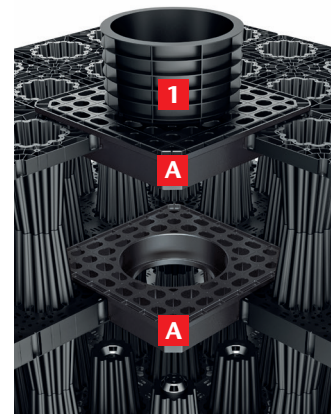

Completely installed attenuation/infiltration system with ACO StormBrixx HD:

- Shaft base or intermediate part (B) at the edge of the infiltration system
- Upper part (1)



Entrance via access chamber

For ACO StormBrixx HD, the access chamber (B) can be located anywhere within the system including the outer edge of the block attenuation/infiltration as a connection and inspection chamber. In multi-layer infiltration systems the access chamber and intermediate parts are simply assembled on top of each other.

Each access chamber can be cut out on site for different pipe size connections according to the in situ requirements. It is advisable to make a predrilled hole for the saw blade. The top of the chamber is added with ACO StormBrixx upper parts (1). The height is variable and is adapted to the ground level. An access cover rounds off the modular system.

Only in conjunction with StormBrixx HD

The access chamber can be used at the edge of the infiltration system for inspection and cleaning. A lateral pipe connection DN/OD 400 can be made via this.

Access chambers are connected with individual connectors at the edge of the basic element. Do not use connectors on the underside!

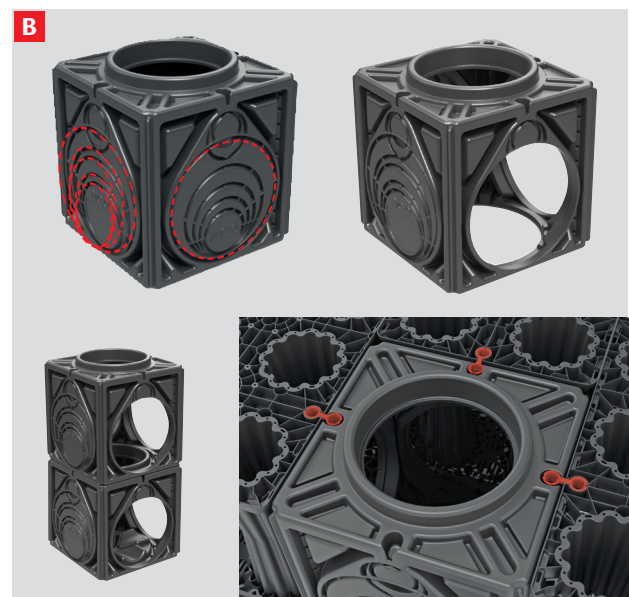

Manholes

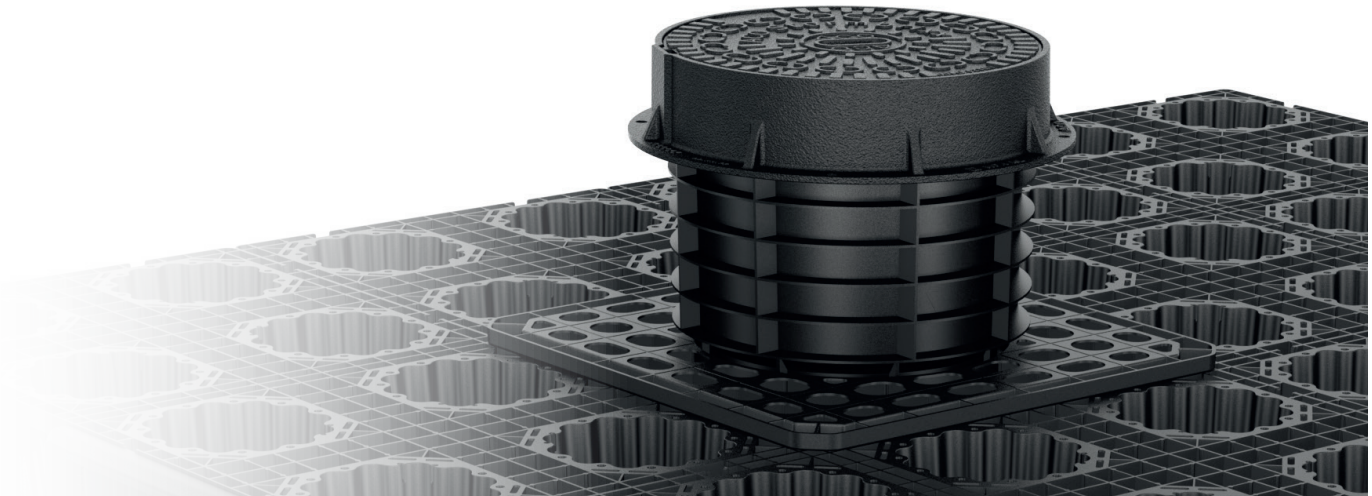

ACO StormBrixx offers options for accessing the system with a sewer camera or jetting nozzle or lance for inspection or maintenance of the block infiltration system. Shaft upper parts enable access to the StormBrixx system from the surface.

The riser pieces have a push-fit connection which can be adjusted to the longitudinal and transverse gradient on site and can be telescopically adjusted vertically (+/- 30 mm). They are watertight up to 0.5 bar.

Load separation and vertical alignment of the individual components are ensured by the telescope principle.

Any settlement that occurs in the backfill area can be absorbed by the tolerance window in the telescope. The load of the shaft cover is dissipated by the support of the shaft frame in a fresh concrete bed.

Caution

- Before inserting upper sections, remove protective film from seal and clean it
- Seals must be coated with a suitable lubricant
- Upper section must be inserted to at least the minimum insertion depth

Inset the upper sections

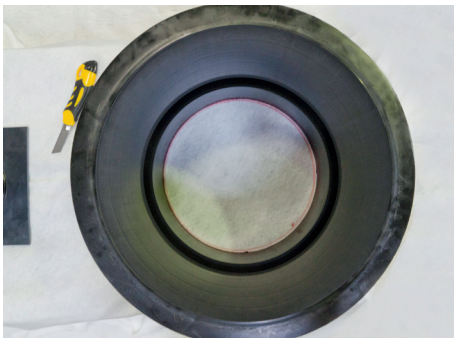

Drawing the inner diameter

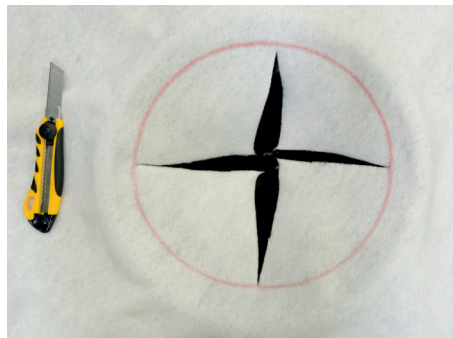

Cutting a cross within the marked circle

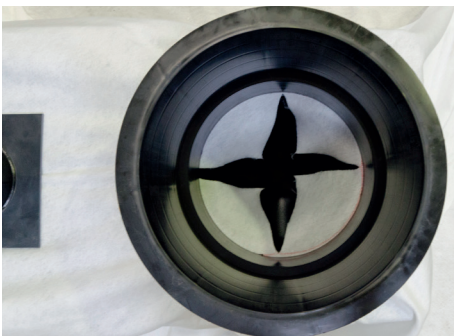

Installing the intermediate section (= sand tight)



Insert to at least the minimum depth!

Inspection via different access points

ACO StormBrixx HD

At the edge of the box via the StormBrixx upper part (inner diameter = 339 mm), in connection with the access chamber (inner diameter = 400 mm)

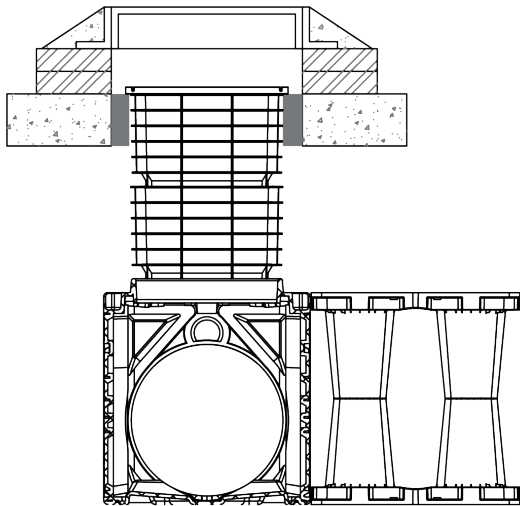

ACO StormBrixx HD

Within the box via the ACO StormBrixx upper part (inner diameter = 339 mm) in connection with the access plate (inner diameter = 400 mm)

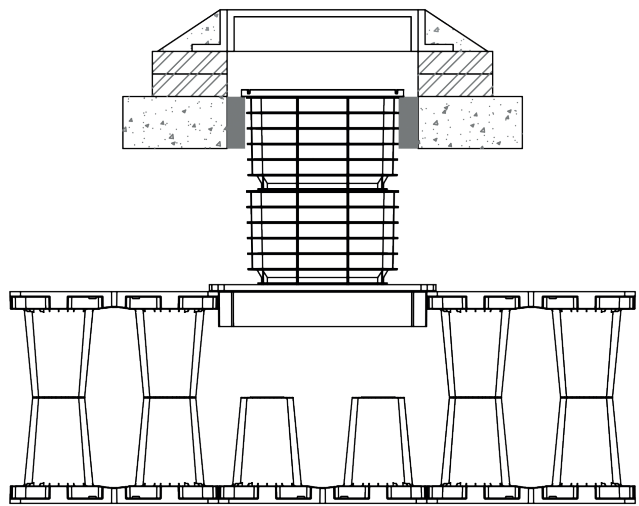

ACO StormBrixx SD

Within the box via the ACO StormBrixx upper part (inner diameter = 339 mm) in connection with the access plate (inner diameter = 400 mm)

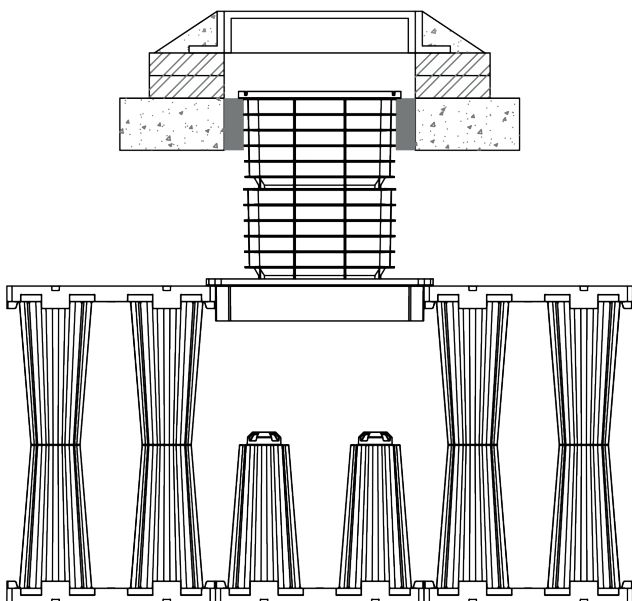

Access Covers D 400



The access cover has a maintenance free, screw-free and traffic-safe catch made from highly wear-resistant plastic (conforms to BS EN 124 / BS EN 1229, is stable at extreme temperatures, repels dirt, is self-locking and vandal-proof).

Once the cover has been put in place, it can be locked into place by stepping on it vertically on the area sitting over the frame. A concrete seating surrounding the upper section provides the load transmission for the shaft cover. A concrete seating C12/15 approx. 20 cm wide is created all the way around, as defined by BS EN 206-1, and raised by 2 cm to the highest drain upper section.

Use the inserted temporary cover/formwork to smooth off the inserted concrete flush. Then remove the temporary cover/formwork, press the frame into the wet cement base to a depth of approx. 2 cm until it is completely seated on the upper shaft section or as required for the final height.

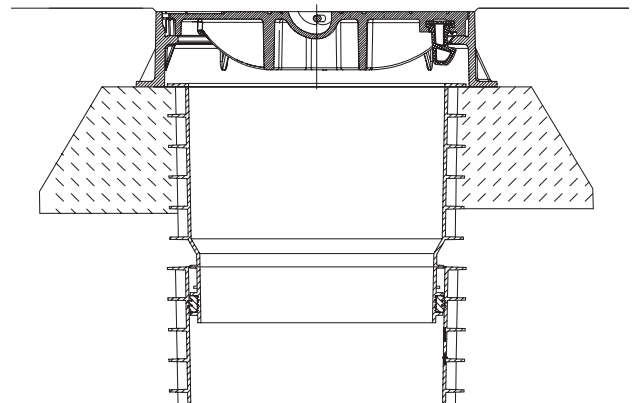

Depth of concrete: 20 cm

Concrete quality: \geq C12/15



-
- [ACO Water Management](#)
[Civils + Infrastructure](#)
[Building + Landscape](#)
 - [ACO Building Drainage](#)
 - [ACO Access](#)
 - [ACO Sport](#)
 - [ACO Wildlife](#)
-

ACO Water Management

A division of ACO Technologies plc

ACO Business Park
Hitchin Road
Shefford
Bedfordshire
SG17 5TE

Tel: 01462 816666
Orders: customersupport@aco.co.uk
Enquiries: uk-swc@aco.co.uk
Technical support: suds@aco.co.uk

www.aco.co.uk

**ACO. creating
the future of drainage**

