

DC Admin

From:
Sent: 24 March 2026 20:37
To: Louise Bearcroft; DC Admin
Subject: Subject: Objections Planning Application: 2025/61/92713 and 2025/44/92737

CAUTION: External email. Do not click links or open attachments unless you recognize the sender and know the content is safe.

Ms Bearcroft

The above application has recently received additional information/amendments.

This plan [id 1130493] is now showing the habitable lounge window and the conservatory at 21 Summerdale, looking towards the boundary of this proposed site.

The distances on this plan between Plot 10 and 21 Summerdale are:

Conservatory (rear corner) (habitable room) is 6150

Lounge (habitable window) is 10717

Plot 10's gable end wall to 21 Summerdale is 8786

None of the above measurements comply with the minimum separation distance of 12 metres as specified in Kirklees own SPD's.

Unnecessary and Irrelevant measurements:

Plot 10 to 23 Summerdale 15109. **23 Summerdale is not even on the boundary of this development** and is located further away within Summerdale's cul-de-sac so why has this measurement been included????? **Very misleading**

21 Summerdale to its own wooden fence 11001. Not relevant to Plot 10. Why mention this????**Very misleading**

Also on this plan, the window in the gable end wall of 21 Summerdale has been categorised as a *secondary ground floor window to lounge*. **Very misleading.**

I can only assume this terminology has been used to try and devalue the importance of this habitable window. This habitable window measures 1230mm x 1200mm. The opening part is 1090 mm x 540mm. The internal window sill height is 950 mm. All these measurement, far exceed the criteria required for a primary window; therefore, this window **is** a primary window. The two windows in our large through lounge meet primary window classification.

This house was built with two primary windows to allow enough natural light into this through lounge and means of escape.

Secondary windows are fixed glazed, usually of small size, with no opening mechanism. Therefore preventing escape in the event of an incident, stopping you getting out of the house, when necessary.

Therefore the separation distance between this primary habitable window and Plot 10 should be 12 metre and not 10.717 as shown on the plans.

The conservatory shown on the plan was not part of the original structure of the house. This is the first time that it has been shown on any of the submitted plans.

Therefore, as Kirklees planning has allowed the developer to take measurements from our conservatory, then, Kirklees Planning in **Fairness and Openness**, to all parties, should allow us to also take measurement from the same point.

This means the separation distance between the conservatory and Plot 10 should be 12 metres not 6.150 metre. This measurement of 6.150m shown on the plan is not complying with the 12 metre minimum separation distance as per Kirklees SPD.

A document that Kirklees Planning supplied to Planning Sub Committee Members for clarification regarding separation distances stated:

REPORT TO PLANNING SUB-COMMITTEE (HUDDERSFIELD) ON 28

AUGUST 2008– STATUS: PUBLIC

TITLE: NOTE OF CLARIFICATION ON UNITARY DEVELOPMENT PLAN

***POLICY BE12 FOLLOWING THE OUTCOME OF A COMPLAINT TO THE
LOCAL GOVERNMENT OMBUDSMAN***

DETAILED INFORMATION

This report is brought before the Sub-Committee as a result of a recommendation by the Ombudsman that clarification should be made to Members on Officers' interpretation of UDP Policy BE12, commonly known as the policy on space about buildings, in respect of the dimensions applied to existing dwellings adjacent to new development proposals.

The following diagram was submitted with the above report to Planning Sub Committee members to clarify the interpretation of BE12

Interpretation of Policy BE12

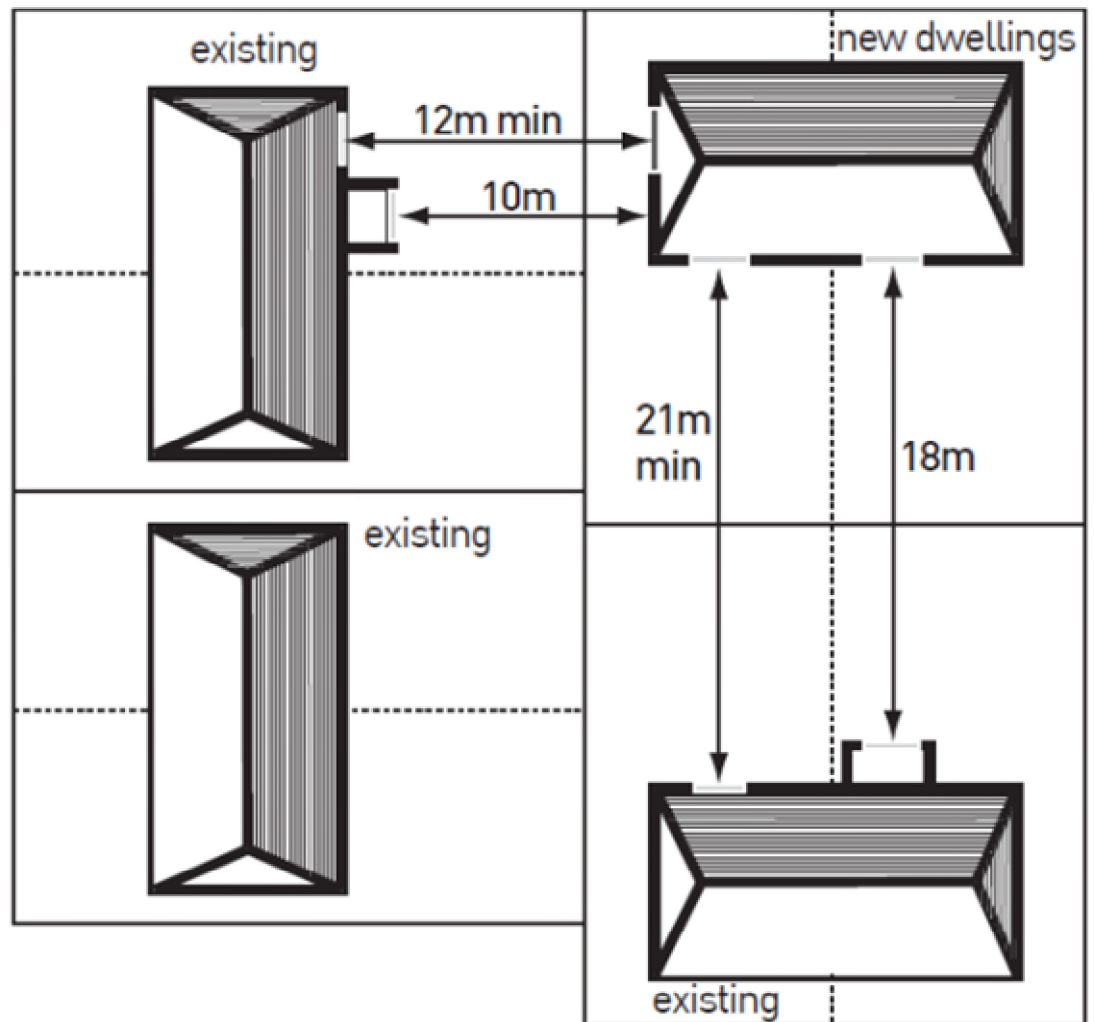

*Policy BE12 applies only to proposals for new dwellings to achieve privacy and open space for future occupants and separation from adjacent property and land. The policy identifies minimum acceptable distances between habitable and non-habitable rooms which will normally be acceptable. The commentary to the policy defines habitable rooms as including lounges, dining rooms, bedrooms, living-kitchens, studies and conservatories. **The distances are seen as basic standards to ensure clarity.***

Even though the Unitary Development Plan has now been superseded by the Local Plan. The UDP Policy BE12 is a **Saved Policy** and therefore still applicable.

Kirklees Planning, on this planning application, is not adhering to their own interpretation, (shown above) that they supplied to Sub-Committee members to follow.

In Kirklees Housebuilders Design Guide SPD Page 26 it specifies that we should have 12 metres minimum separation distance.

Important note. If a development site's ground is steeply sloped, separation distances should be increased (e.g., adding 2 metres of separation for every 1 metre of elevation difference).

In Kirklees Housebuilders Design Guide SPD, Page 27, it specifies:

7.21 Longer distances between buildings may be necessary if:

- ***Steep topography on the site, which presents challenges relating to overlooking.***

This development site has a very steep topography. Therefore, longer separation distances between these two buildings are necessary.

This means that the separation distance between Plot 10 and 21 Summerdale, should be increased from 12 metres to 13.6 metres i.e.12 metres + 1.6 metres allowance, for the plot topography.

Taking the same measuring point (from the conservatory), as the developer, the 13.6 metres separation distance should be measured from 21 Summerdale's conservatory (habitable room).

All these factors and extra measurements confirm that Plot 10 will, overlook and overshadow the house, conservatory and gardens at 21 Summerdale.

This planning application will seriously impact on the residential amenity of 21 Summerdale, in terms of Loss Of Light, Loss of Privacy, Overbearing, Overlooking and Overshadowing.

The proposed dwelling will affect the privacy, outlook and natural light, currently enjoyed by the existing residents at 21 Summerdale, to a significant degree.

Please log the above objection against the case files for both planning applications 2025/92737 and 2025/92713

Regards