

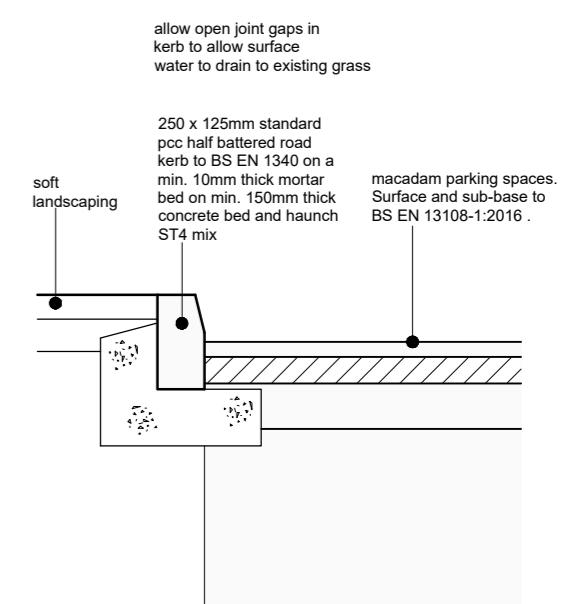

site plan



kerb detail

This drawing has been prepared specifically for the purpose of obtaining Planning Permission and/or Building Regulation Approval. Its suitability for other purposes, without supplementary details and specifications cannot be guaranteed. The Permissions and/or Approvals are beyond the Architects control, and no guarantee that such will be granted is given or to be inferred by reason of the preparation of this drawing.

Only figured dimensions are to be used. All dimensions to be checked on site. This drawing together with the design is the property and copyright of the Architect and must not be reproduced without prior written permission.

P06	added redline boundary as requested by planning	18.03.25	JW	NG
P05	amended rear planting to suit BNG metric calculations	12.03.25	JW	NG
P04	added new tree planting further to small sites metric calculations	15.01.25	JW	NG
P03	added wildflower planting	11.12.24	JW	NG
P02	added additional parking space	11.12.24	JW	NG
P01	Drawing originated	09.12.24	JW	NG
rev.	description	date	drawn	approved



project New staff car parking spaces
at
KAL, Holmfirth Pool & Fitness,
Huddersfield Road, HD9 3JL
for
Mel Green Construction

title Site plan as proposed
number 24114D-02-P06
scale 1:200 / 1:20
size A2