

ARBORICULTURAL METHOD STATEMENT
to BS 5837:2012
at
Wappy Spring Inn
Lindley Moor Road
Huddersfield
West Yorkshire
HD3 3TD

Client:

Frank Marshall Estates

Client Address:

Unit 2B
Link 606 Office Park
Staithegate Lane
Bradford
West Yorkshire
BD6 1YA

JCA Ref:

22184-A/AJB

Contents

1. Introduction.....	3
2. Tree Works Prior, During and Post Construction.....	4
3. The Protective Fencing Prior, During and Post Construction	5
4. Demolition Phase / Construction Phase.....	7
4.1 Demolition Works.....	7
4.2 Ground Level Changes.....	7
4.3 Construction of Hard Surfaces.....	7
4.4 Construction of New Buildings	7
4.5 Excavations and Services	7
4.6 Location of the Site Compound.....	7
5. Post Construction Phase	8
5.1 Post Construction Landscaping.....	8
6. Timescale of Works.....	9
7. Relevant Contact Details.....	9
Appendix 1: Tree Works Schedule.....	11
Appendix 2: Protective Barrier	12
Appendix 3: Utilities and Drainage	14
Appendix 4: Tree Protection Plan	16

1. Introduction

1.1 Purpose of the Method Statement

1.1.1 This Arboricultural Method Statement has been prepared to ensure good practice in the protection of retained trees during the development at **Wappy Spring Inn, Lindley Moor Road**.

1.2 Terms of Reference

1.2.1 JCA Limited is instructed by **Frank Marshall Estates** to prepare an Arboricultural Method Statement for the proposed development, based on our arboricultural report dated 8th August 2024 (JCA Ref: **22184/AJB**). The arboricultural survey and report conform to the most recent specifications outlined in BS 5837: 2012 *Trees in relation to design, demolition and construction - Recommendations*.

1.2.2 We are informed that the planning application seeks permission for the erection of 15no. small scale, hybrid industrial units with associated external yard areas and parking.

1.2.3 The following drawings have been provided, and these are the basis of the Arboricultural Method Statement and the Tree Protection Plan at **Appendix 4**:

- Topographical Survey (Drawing Ref. **P20-01094-MET-EXT-XX-TOP-M3-G-1-3d topographical survey**).
- Development Layout (Drawing Ref. **2002 REV C PROPOSED SITE PLAN**).

1.3 Status of the Method Statement

1.3.1 This Arboricultural Method Statement should be included as part of the specification and schedule of works issued to the building contractor and can form part of the contract.

1.3.2 This Arboricultural Method Statement should be available on site for inspection by the local authority, contractors and other relevant persons.

2. Tree Works Prior, During and Post Construction

2.1 Tree Works Prior to Construction

- 2.1.1 Prior to any construction activity, the first operation on site will be the undertaking of the necessary arboricultural works, as described at **Appendix 1**.
- 2.1.2 The tree works include:
- The pruning of **T2**, for arboricultural reasons.
 - The potential pruning back of trees within **G1**, in order to facilitate the development.

2.2 Tree Works During or Post-Construction

- 2.2.1 In this case, no tree works are envisaged to be required during or after the construction phase.
- 2.2.2 Damage to trees during the construction phase should be entirely prevented by the installation of the temporary protective fencing to create a Construction Exclusion Zone (CEZ). All persons on site must be aware of limitations that apply within the CEZ (please refer to **Section 3.1.3**).
- 2.2.3 If any trees on site are damaged, this must be immediately reported to JCA to agree on appropriate remedial action. Contact numbers for all parties can be found at **Section 7**.

2.3 Recommendations For Tree Works

- 2.3.1 All work must be undertaken to BS 3998: 2010 - *Recommendations for tree work* and carried out by qualified, experienced and, ideally, Arboricultural Association approved contractors who must be adequately insured.
- 2.3.2 Any defects seen by a contractor or the client that were not apparent to the consultant must be brought to the attention of JCA immediately.
- 2.3.3 No liability can be accepted by JCA in respect of the trees unless the recommendations of this Method Statement are carried out under our supervision.

3. The Protective Fencing Prior, During and Post Construction

3.1 Protective Barrier Prior to Construction

- 3.1.1 The installation of the temporary protective fencing will be the very first job to be undertaken on site following the completion of the tree works (**Section 2.1**).
- 3.1.2 The protective fencing must be constructed in accordance with BS 5837: 2012 *Trees in relation to design, demolition and construction - Recommendations* and will be located as shown on the Tree Protection Plan at **Appendix 4**. The protective barrier will enclose the entire Root Protection Area (RPA) retained trees to create a Construction Exclusion Zone (CEZ); **this area is to be considered a restricted area; no pedestrians, vehicles, equipment or machinery are allowed within the CEZ and the storage of materials is not permitted, unless specified within this Method Statement.**
- 3.1.3 The protective fencing will be installed in accordance with BS 5837: 2012 and will comprise of a vertical and horizontal scaffold framework, well braced to resist impacts. The vertical tubes should be spaced at a maximum interval of 3m and driven securely into the ground, taking care to avoid underground services and structural roots. Finally, weld mesh panels are to be securely fixed on the scaffold framework. Please refer to **Appendix 2** for protective fencing details.
- 3.1.4 Once the fencing is installed, waterproof signs with the sentence '*Protected tree zone, no storage or operations within this area*' are to be placed at 3m intervals to ensure that all personnel are aware of the restrictions that apply to the cordoned off area. A prepared sign is available at **Appendix 2**.

3.2 Ground Protection

- 3.2.1 Ground protection is not required for retained trees on this occasion.

3.3 Checking the Protective Fencing Prior to Construction

- 3.3.1 Once installed, the appointed arboriculturalist will be invited on site to inspect the protective fencing, ensuring that it is located in the correct position and that it has been constructed in accordance with this Method Statement. No other work, including soil stripping, excavation, or the bringing onto site of materials or machinery, shall commence until the barrier is installed and confirmed to be acceptable by the appointed arboriculturalist.
- 3.3.2 It is important that the protective fencing be checked and signed off by the arboricultural consultant prior to any construction works being carried out on site.

3.4 Protective Fencing During Construction

- 3.4.1 No operations shall take place which require the removal of part of the protective fencing without prior agreement with the Local Planning Authority.
- 3.4.2 **If at any time during construction the protective fencing is setback or removed without permission, or if it does not comply with BS 5837: 2012, this could result in damage being caused to trees and consequently, a stop notice may be served by the LPA.**
- 3.4.3 The protective fencing must be inspected for faults or damage by the site manager or other responsible named person on a regular basis and a written record kept. Any faults or defects must be repaired or replaced as soon as is reasonably practicable. Details of the site manager and relevant contact details can be found at **Section 7**.

3.5 Removal of the Protective Fencing

- 3.5.1 When the development phase is complete and the main site machinery has been removed, the protective fencing may be dismantled and removed from site.
- 3.5.2 It should be noted the same restrictions apply to all RPAs as the CEZ (please refer to **Section 3.1.2**).

4. Demolition Phase / Construction Phase

4.1 Demolition Works

4.1.1 In this case, no demolition works are required adjacent to retained trees.

4.2 Ground Level Changes

4.2.1 To the knowledge of JCA, no ground level changes are required within the RPA of any tree to be retained on this site. As such no mitigation actions are considered necessary.

4.3 Construction of Hard Surfaces

4.3.1 In this case, no new hard surfaces are proposed within the RPA of retained trees. As such, no specialist mitigation actions are required.

4.4 Construction of New Buildings

4.4.1 In this case, the proposed buildings are located at a sufficient distance from retained trees that no specialist foundation methods are required for arboricultural purposes.

4.5 Excavations and Services

4.5.1 Details on service routes are not available at this time. As such, no provision for the routing of utilities within the RPAs is made within the scope of this report.

4.5.2 All utilities should ideally be located outside the RPA of retained trees. If, for whatever reason, incursions into the RPAs are considered unavoidable, the consulting arboriculturalist and/or the LPA must be consulted immediately, to prevent a breach of planning conditions and/or damage to retained trees.

4.6 Location of the Site Compound

4.6.1 The site compound, typically including the site office, mess facilities, toilets, storage of materials and parking, must be located away from, and outside the RPA of retained trees.

4.6.2 Those areas designated for the storage and/or mixing of chemicals, including petrol, diesel and oils must also be located away from, and outside the RPA of retained trees. Such areas should be constructed with consideration to, and contingencies for, the occurrence of spillages, preventing the leaching of chemicals into unprotected, open ground.

5. Post Construction Phase

5.1 Post Construction Landscaping

- 5.1.1 Following completion of the main construction phase, the protective fencing may be removed, and the landscaping phase can commence.
- 5.1.2 The proposals may include for the installation of boundary fences. Where these are located within the RPA of retained trees, post holes will be dug by hand and they are to be as small as practically possible. They may be driven in either by hand or using mechanical means. However, if construction plant is to be used, it must work from outside of the RPA at all times.
- 5.1.3 The retained trees on site may be subject to some form of landscaping or seeding beneath their canopies after the development phase. At this stage the protective fencing will have been removed.
- 5.1.4 Landscaping works must be carried out in such a way as to avoid ground level changes or deep digging within RPAs. Tractor mounted rotovation or other mechanised cultivation methods must not be used within the RPAs of retained trees.
- 5.1.5 Heavy machinery is not permitted in the vicinity of retained trees, unless otherwise stated in this method statement.
- 5.1.6 Herbicides should be appropriate for the purpose and should not be used in such a way as to damage any retained trees or vegetation.

6. Timescale of Works

6.1.1 The timescales for arboricultural requirements are summarised below:

Timescale	Action	✓	Initial
Stage 1	All requirements listed in the planning consent are approved by the Local Authority planning office.		
Stage 2	Undertake the tree works (as detailed at Appendix 1).		
Stage 3	Install the temporary protective fencing around the trees (as detailed at Appendix 2 and as shown on the Tree Protection Plan at Appendix 4).		
Stage 4	Have the Arboricultural Consultant inspect the protective measures prior to any on site construction. Once inspected, the protective fencing must not to be moved or breached.		
Stage 5	Undertake the construction phase.		
Stage 6	Following the completion of the construction phase and when all site traffic and machinery has left, the protective fencing can be removed.		
Stage 7	Undertake the post-construction landscaping scheme in line with Section 5 .		

7. Relevant Contact Details

Contact Name	Organisation/Detail	Contact Number
Andrew Bussey Arboricultural Consultant	JCA Limited	01422 376335
Jack Dunn Tree Officer	Kirklees Metropolitan Borough Council	01484 4149109
TBC Site Manager	TBC	TBC

Appendices

Tree Ref.	Age	Height (m)	Crown Height (m)	Height (m) and Direction of the Lowest Branch	Diameter (cm)	Crown Spread			Observations	Recommendations	Physiological Condition	Structural Condition	Amenity Value	NHBC Water Demand	Life Expectancy (yrs)	Retention Category
	Common Name					W	E	S								
	Botanical Name								Priority							
G 1	Young to semi-mature Mixed species <i>Details in observations</i>	To 13	0+	0+	To 32#	See plan			A group of Common Ash and Beech located on the M62 motorway embankment. Ash Dieback noted to the Common Ash.	Prune back as and where required in order to allow clearance for scaffolding and the proposed units. n/a	GOOD	GOOD	MOD	MOD	40+	B 2
T 2	Mature Sycamore <i>Acer pseudoplatanus</i>	15	1.8	1.8	44	6# 2.8	6.5#	0	Overhanging the footpath and the road. Single-stemmed and leaning with an unbalanced crown and a poor form. Barks wounds present at the base. Deadwood stubs noted.	Crown clean to remove the deadwood. Monitor annually. Moderate	GOOD	FAIR	MOD	MOD	10+	C 1
T 3	Mature Sycamore <i>Acer pseudoplatanus</i>	17	3	3	81	8 7	8#	5	Overhanging the footpath and the road. Twin-stemmed at 6m with a balanced crown. Minor cavities noted. A bark wound is present on the stem at 1.8m. Epicormic growth present from the base to circa 5m.	Monitor annually. Moderate	GOOD	GOOD	MOD	MOD	40+	B 1
T 4	Mature Sycamore <i>Acer pseudoplatanus</i>	17	6	6	55	5 7	10#	5#	Overhanging the footpath and the road. Single-stemmed and leaning with an unbalanced crown and a poor form. Significant bark loss at the base. Moderate cavities throughout.	Monitor annually. Moderate	GOOD	FAIR	MOD	MOD	10+	C 1
T 5	Mature Sycamore <i>Acer pseudoplatanus</i>	16	7	7	54	6 4	2#	6#	Overhanging the footpath and the road. Single-stemmed and leaning with an unbalanced crown and a poor form. Moderate cavities throughout.	Monitor annually. Moderate	GOOD	FAIR	LOW	MOD	10+	C 1
T 6	Mature Sycamore <i>Acer pseudoplatanus</i>	14	7	7	42	2.5 2.5	3#	6#	Overhanging the footpath and the road. Single-stemmed and leaning with an unbalanced crown and a poor form. Moderate cavities throughout. Snapped out branch stubs noted.	Monitor annually. Moderate	GOOD	FAIR	LOW	MOD	10+	C 1

Appendix 2: Protective Barrier

A2.1 The protective barrier will be installed in accordance with BS5837: 2012. The default specification of BS 5837: 2012 (pictured below for reference) recommends a vertical and horizontal, scaffold framework, well braced to resist impacts, with vertical tubes at no more than 3m intervals. These should be driven into the ground. Weld mesh panels should be affixed to this framework with scaffold clamps.

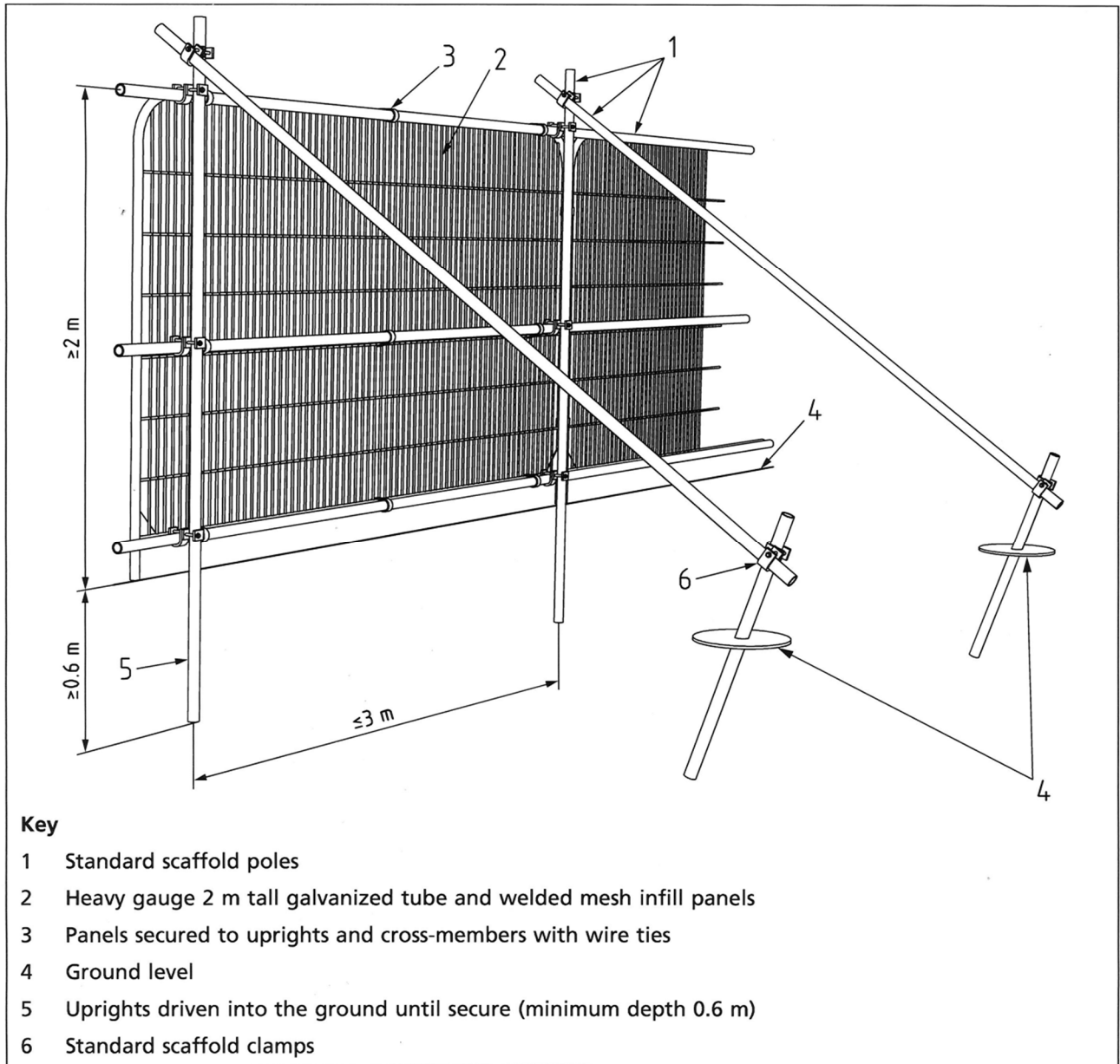

Protective Barrier to BS 5837: 2012.

TREE PROTECTION ZONE

KEEP OUT!

TREES ENCLOSED BY THIS FENCE ARE PROTECTED
BY STRICT PLANNING CONDITIONS

ANY DAMAGE CAUSED TO THESE TREES MAY
RESULT IN CRIMINAL PROSECUTION

RESTRICTED AREA:

- THE PROTECTIVE FENCE MUST NOT BE MOVED OR BREACHED
- NO PERSON, MACHINERY, VEHICLE OR PLANT IS PERMITTED WITHIN THE TREE PROTECTION ZONE
- NO MATERIALS SHALL BE STORED WITHIN THE TREE PROTECTION ZONE
- NO EXCAVATIONS ARE PERMITTED WITHIN THE TREE PROTECTION ZONE
- NO SPOIL IS TO BE DEPOSITED WITHIN THE TREE PROTECTION ZONE
- NO FIRES ARE TO BE LIT WITHIN THE TREE PROTECTION ZONE

REPORT TREE DAMAGE TO JCA LIMITED ON
01422 376 335

Appendix 3: Utilities and Drainage

- A3.1 Over-ground services should be routed away from areas where they are likely to interfere with the crowns of trees. Similarly any landscaping should take account of over-ground services and mature tree size.
- A3.2 Underground services must be routed outside the RPA of retained trees, unless otherwise specified within this report. NJUG Volume 4 Issue 2 (on the next page) is a set of accepted guidelines for installing services in the proximity of trees. Please note that this is not a substitute for site-specific advice by an arboriculturalist and consultation should be made wherever incursions of RPAs are envisaged. The contents of this report, specifically **Section 4.5**, supersede the set of guidelines on the next page, which are only included for reference.



NJUG Guidelines for the Planning, Installation and Maintenance of Utility Apparatus in Proximity to Trees – Issue 2

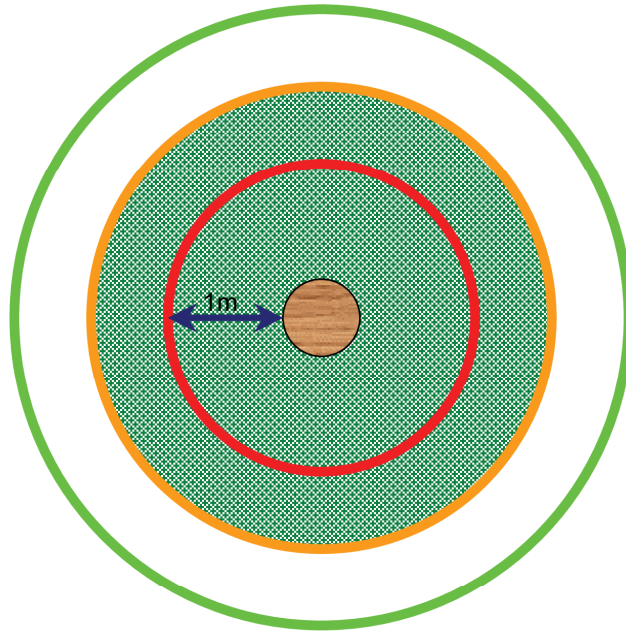

TREE PROTECTION ZONE

Key to Diagram



Trunk of Tree



Spread of canopy or branches



PROHIBITED ZONE – 1m from trunk. Excavations of any kind must not be undertaken within this zone unless full consultation with Local Authority Tree Officer is undertaken. Materials, plant and spoil must not be stored within this zone.



PRECAUTIONARY ZONE – 4 x tree circumference. Where excavations must be undertaken within this zone the use of mechanical excavation plant should be prohibited. Precautions should be undertaken to protect any exposed roots. Materials, plant and spoil should not be stored within this zone. Consult with Local Authority Tree Officer if in any doubt.



PERMITTED ZONE – outside of precautionary zone. Excavation works may be undertaken within this zone however caution must be applied and the use of mechanical plant limited. Any exposed roots should be protected.

Default specification for a protective barrier

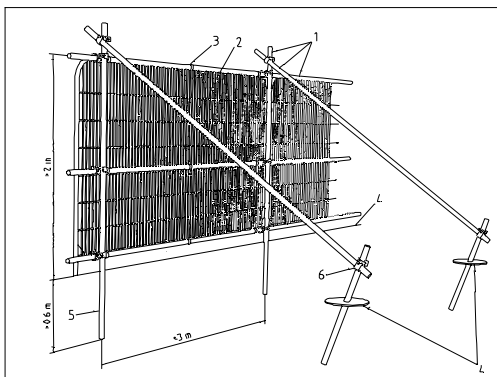

- Key
1. Standard scaffold poles
 2. Heavy gauge 2m tall galvanized tube and welded mesh infill panels
 3. Panels secured to uprights and cross-members with wire ties
 4. Ground level
 5. Uprights driven into the ground until secure (minimum depth 0.6m)
 6. Standard scaffold clamps



THIS PLAN IS TO BE PRINTED IN COLOUR AND READ IN CONJUNCTION WITH THE JCA ARBORICULTURAL REPORT (JCA REF: 22184-A/AJB)



TREE PROTECTION MEASURES

THE ROOT PROTECTION AREA (RPA) SHOULD IDEALLY REMAIN UNDISTURBED IF THE TREE IS TO BE RETAINED.

UNLESS OTHERWISE STATED IN THE ARBORICULTURAL METHOD STATEMENT, THE RPA NEEDS TO REMAIN UNDISTURBED.

TO ACHIEVE THIS, PROTECTIVE FENCING WILL BE INSTALLED TO ENCLOSE THE RPA TO MAKE A CONSTRUCTION EXCLUSION ZONE (CEZ).

THIS AREA IS TO BE CONSIDERED A RESTRICTED AREA: NO PEDESTRIANS, VEHICLES, THE STORAGE OF MATERIALS, EQUIPMENT OR MACHINERY ARE ALLOWED WITHIN THE CEZ UNLESS SPECIFIED WITHIN THE ARBORICULTURAL METHOD STATEMENT.

IT IS IMPORTANT THAT THE PROTECTIVE FENCING IS CHECKED BY THE LPA OR THE ARBORICULTURAL CONSULTANT PRIOR TO ANY CONSTRUCTION WORKS BEING CARRIED OUT. IF THE TREE PROTECTION MEASURES ARE NOT CORRECTLY INSTALLED OR IF THEY DO NOT COMPLY WITH BS 5837: 2012, THIS COULD RESULT IN DAMAGE BEING CAUSED TO TREES AND CONSEQUENTLY A STOP NOTICE MAY BE SERVED BY THE LPA.

Appendix 4: Tree Protection Plan

ADDRESS: Wappy Spring Inn, Lindley Moor Road, Huddersfield, West Yorkshire, HD3 3TD.
JCA REF: 22184-A/AJB.

SCALE: 1:500 PAPER SIZE : A3

SURVEYED BY: AJB DRAWN BY: AJB APPROVED BY: CC

	TREE TO BE RETAINED
	STEM OF TREE TO BE RETAINED
	ROOT PROTECTION AREA (RPA)
	PROTECTIVE FENCE LINE (CEZ)

JCA Limited
Arboricultural & Ecological Consultants

I hope that this report provides all the necessary information, but should any further advice be needed please do not hesitate to contact the author.

Signed

.....

Andrew Bussey *LANTRA Accredited PTI.*

21st January 2025

For and on behalf of **JCA Ltd**

Registered Office:

**Unit 80
Bowers Mill
Branch Road
Barkisland
Halifax
HX4 0AD**

**Tel. 01422 376335
Fax. 01422 376232
Email: info@jcaac.com**

www.jcaac.com

JCA Ltd. Arboricultural and Ecological Consultants

Professional Tree and Ecology Advice nationwide

ARBORICULTURAL SERVICES

Guidance for Architects and Developers

- British Standard 5837 Tree Surveys
- Arboricultural Implication Assessments (AIA)
- Arboricultural Method Statements (AMS)

Advice for Engineers, Loss Adjusters and Insurers

- Tree Surveys for Subsidence
- Heave Assessment
- Tree Root Identification

Advice for Local Authorities and Social Housing

- Tree Safety Surveys
- Specialist Decay Detection
- Landscape and Orchard Design

Tree Advice for the Legal Profession

- Subsidence Litigation
- Personal Injury and Accident Investigation
- Expert Witness, Planning Inquiries and Appeals

Veteran Tree Management

- Ancient Woodland Management
- Veteran Tree Management

Tree Health and Pest and Disease Management

- Pest and Disease Surveys
- Tree Health Checks
- Disease Mitigation and Control

ECOLOGICAL SERVICES

Ecological Pre-Planning Services

- Phase 1 Habitat Surveys
- Great Crested Newt eDNA Sampling
- Protected Species: Bat, Wintering and Nesting Bird, Badger, Amphibian, Otter, Water Vole, White-Clawed Crayfish, Dormice and Reptile Surveys.
- Preparation for Environmental Impact Assessment (EIA)
- Invasive Species Surveys
- Code for Sustainable Homes

Ecological Post-Planning Services

- Biodiversity Enhancement Plans
- Protected Species Mitigation
- Ecological Management (Bat and Bird box installation and inspection)

HEAD QUARTERS:

Unit 80 Bowers Mill,
Branch Road,
Barkisland,
Halifax, HX4 0AD.

Tel: 01422 376335
Email: info@jcaac.com
Website: www.jcaac.com

