

Sign A
Scale 1:50 @A3

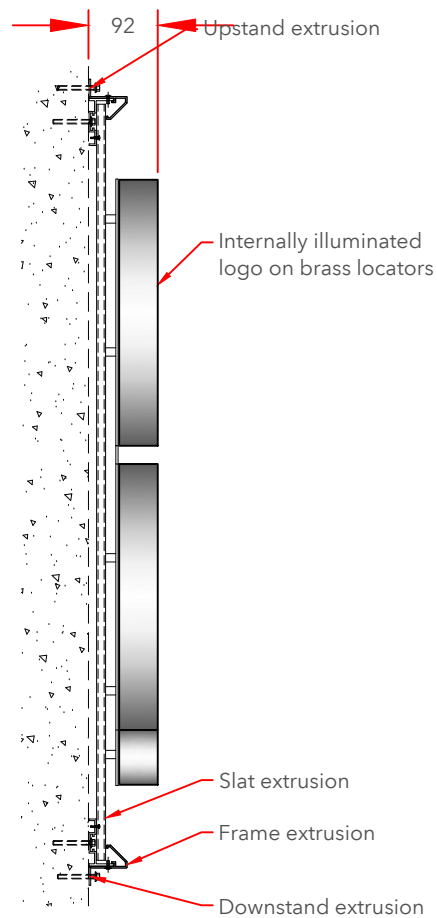

Logo Cross Section
Scale 1:10 @A3

Sign A Specifications:

Fascia

Aluminium slat fascia to suit site conditions.

Fascia constructed from individual Aluminium extrusions. Perimeter support extrusion fixed to the building substrate with suitable fixings, Aluminium vertical slats mounted and fixed to the support extrusion and trimmed around the perimeter with a chamfered trim.

Slat and trim to be finished Dark Grey Wood effect:
Decoral powder coating: 8G-940-A005 (lab code FP 714/38)
Decoral sublimatic Film: 2217/19 L.
(CFP-EX-I/M & CFP-EX-G/DG & CFP-EX-H/DG & CFP-EX-A/DG)

Logo

800mm Single sided built up logo.(CFP-L-WM0800-WM/B)
Steel mounting plate with individual built-up internally illuminated letters. Mounting plate to be 3mm Mild Steel fixed to building substrate with brass locator fixings.

3D built-up letters to have aluminium sides, 50mm deep with 5mm Co-op BLUE acrylic faces. All visible edges, aluminium returns & mounting plate to be finished Silver RAL 9006 60% gloss.
Internally illuminated by white LEDs.

Letters

"Welcome to Anytown Co-op" 234mm to match 800mm logo to be from 5mm WHITE Perspex 069 Acrylic on locator snap fixings.(CFP-WL0800-A/W)

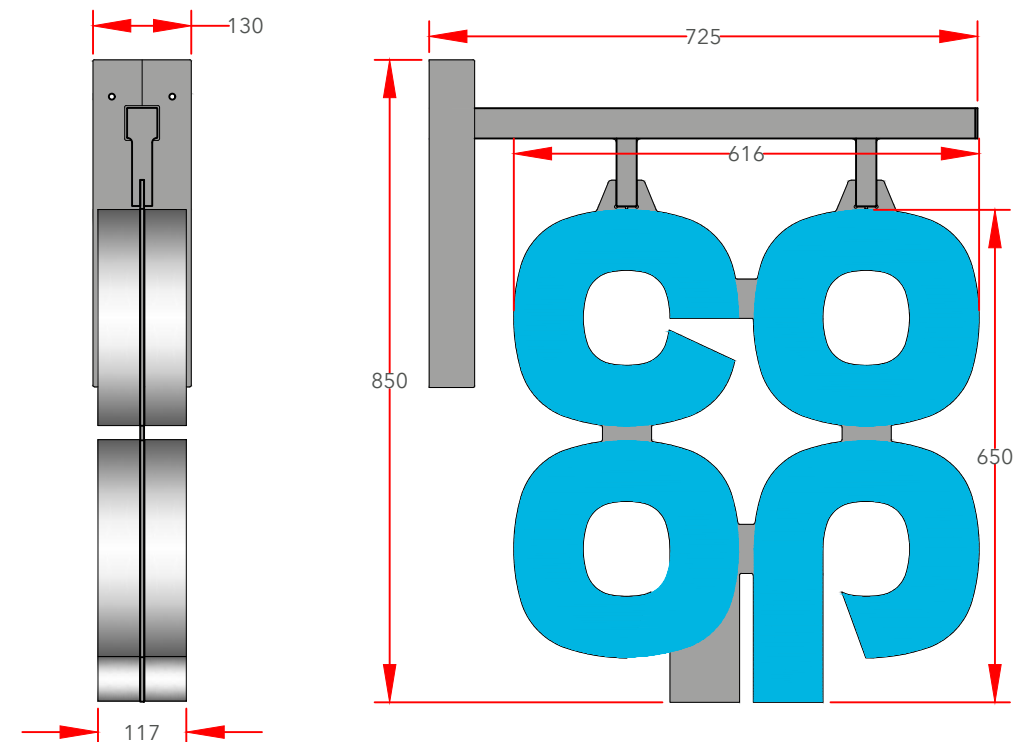

650mm
Scale 1:10 @A3

Sign B Specifications:

Projection sign size 650mm Internally Illuminated built up letters on both sides. Individual 3D letters constructed from silver aluminium side returns and Co-op BLUE acrylic faces - faces only to illuminate.

Fully welded 5mm Mild Steel wall mounting plate and support frame. Profile cut logo mounting plate from 5mm Mild Steel, welded to the hanging tubes. All visible steel work to be finished silver to match RAL 9006 60% gloss.(CFP-P-FF0650/B).

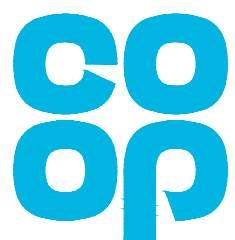

Collections

Store Name: Meltham
Store No: 7365
Futurama W.O: 129771
Store Type: Everyday Convenience - Mainstream
Programme: Rollback
CAD reference: N/A

Address: 18-24 Huddersfield Road
Meltham Huddersfield
West Yorkshire
HD9 4AE
Revision: -
Original Scheme: AR

Olympia House
Lockwood Court
Middleton Grove
Leeds
LS11 5TY
United Kingdom
Telephone: 0113 270 5595
Facsimile: 0113 277 1143
E-mail: postbox@futurama.ltd.uk



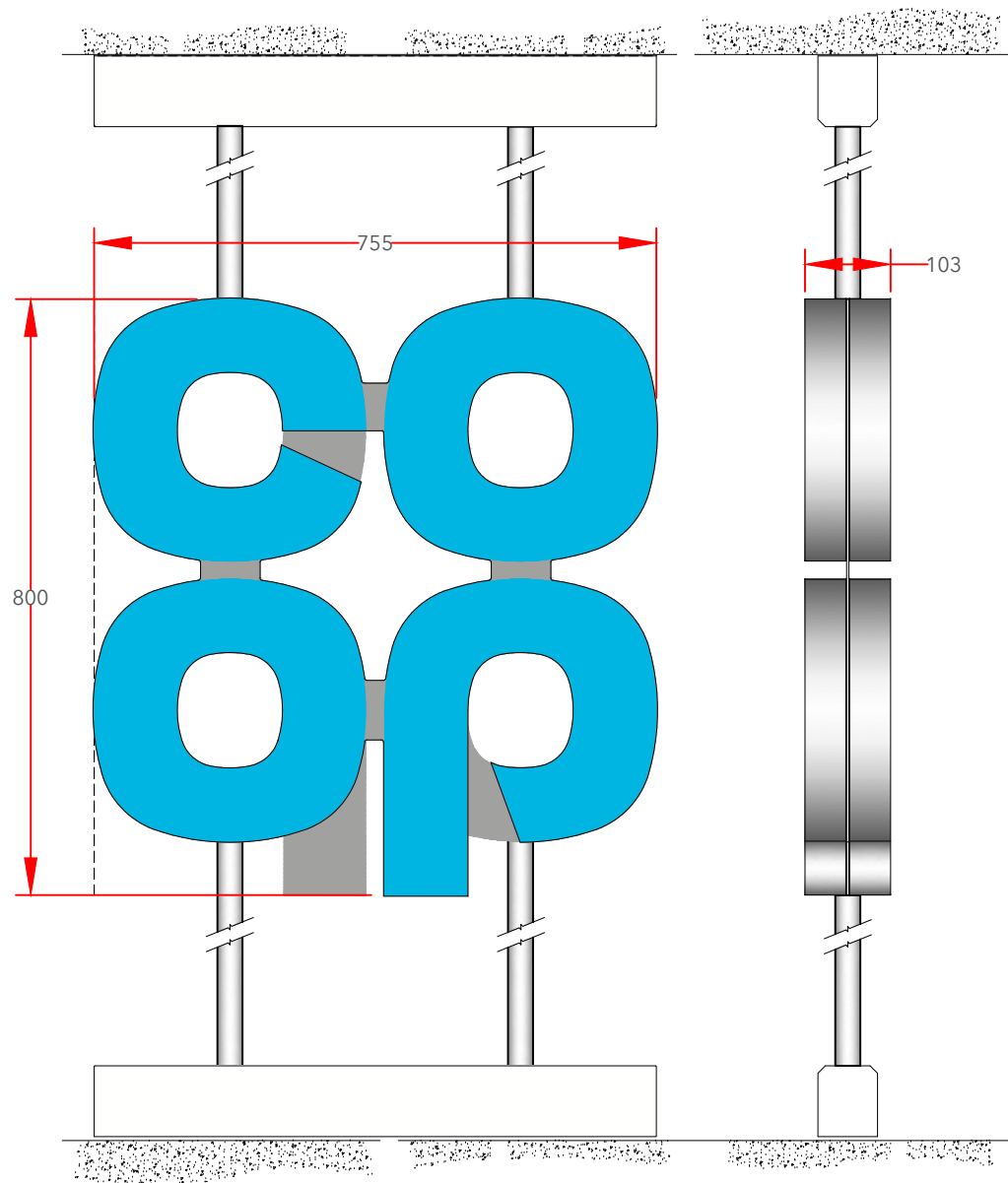

Sign C Specifications:

800mm Double sided built up logo. Steel mounting plate with individual built-up letters, exterior facing letters to be internally illuminated, interior facing letter to be non-illuminated. Mounting plate to be 3mm Mild Steel fixed to poles at top and bottom.

3D built-up letters to have aluminium sides, 50mm deep with 5mm Co-op BLUE acrylic faces. All visible edges, aluminium returns & mounting plate to be finished Silver RAL 9006 60% gloss. Internally illuminated by white LEDs. (CFP-P-FF0800-S/B)
Scale 1:10

Ref No: 800 (Ø33.7 tubes)

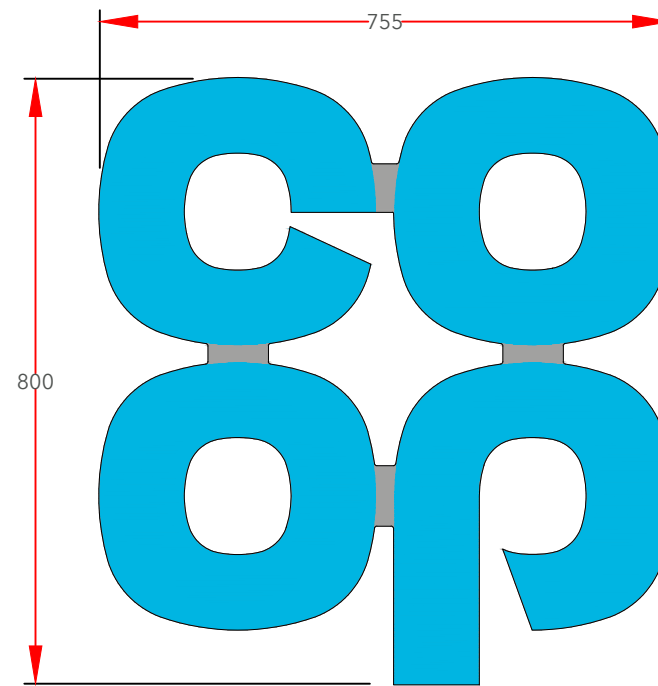

800mm
Scale 1:10 @A3

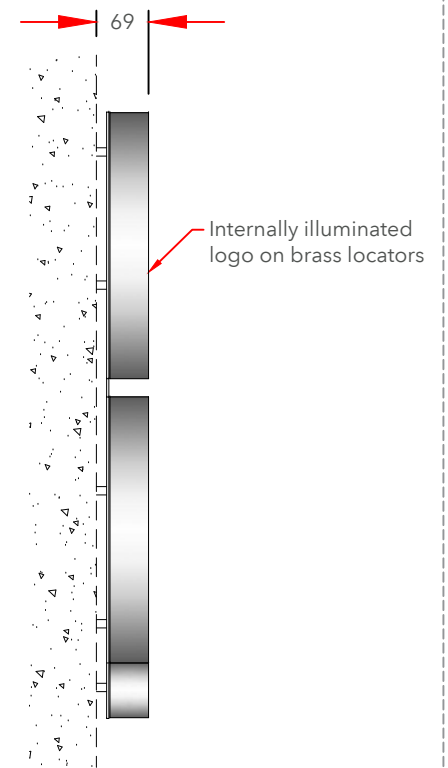

Cross Section
Scale 1:10 @A3

Sign D Specifications:

800mm Single sided built up logo. Steel mounting plate with individual built-up internally illuminated letters. Mounting plate to be 3mm Mild Steel fixed to building substrate with brass locator fixings.

3D built-up letters to have aluminium sides, 50mm deep with 5mm Co-op BLUE acrylic faces. All visible edges, aluminium returns & mounting plate to be finished Silver RAL 9006 60% gloss. Internally illuminated by white LEDs. (CFP-L-WM0800/B)



Collections

Store Name: Meltham
Store No: 7365
Futura W.O: 129771
Store Type: Everyday Convenience - Mainstream
Programme: Rollback
CAD reference: N/A

Address: 18-24 Huddersfield Road
Meltham Huddersfield
West Yorkshire
HD9 4AE
Revision: -
Original Scheme: AR

Olympia House
Lockwood Court
Middleton Grove
Leeds
LS11 5TY
United Kingdom
Telephone: 0113 270 5595
Facsimile: 0113 277 1143
E-mail: postbox@futura.ltd.uk





Sign E1 & E2 - Scale 1:10

450mm dia parking roundel "Remember your reusable bags". 3mm ACM with applied vinyl display & anti-graffitti laminate. Non-illuminated. (CFP-CP-0450-I002)

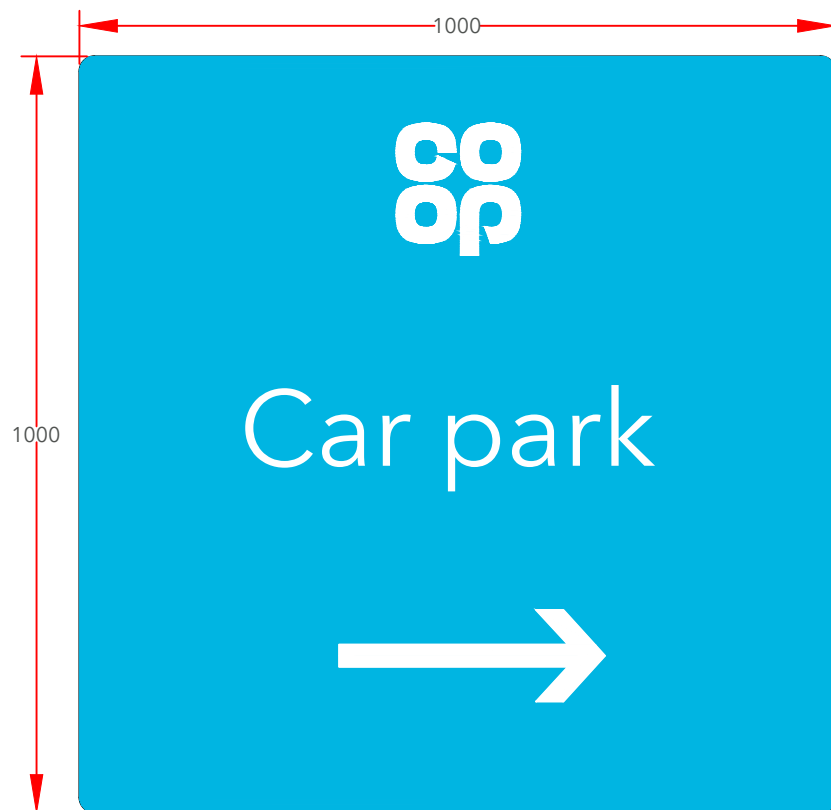

Sign F - Scale 1:10

1000mm x 1000mm "Car park (arrow)" non-standard parking sign. 3mm ACM with applied vinyl display & anti-graffitti laminate. 20mm radius corners. Non-illuminated. (CFP-CP-129771 - F) 900mm H.A.G.L.

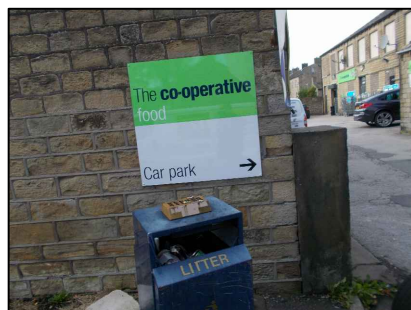

Existing

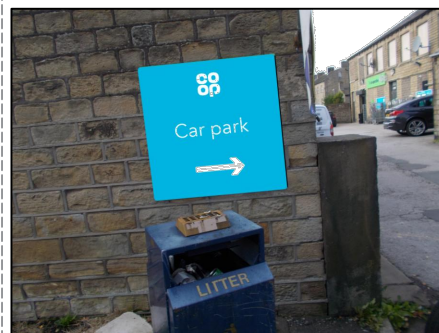

Proposed

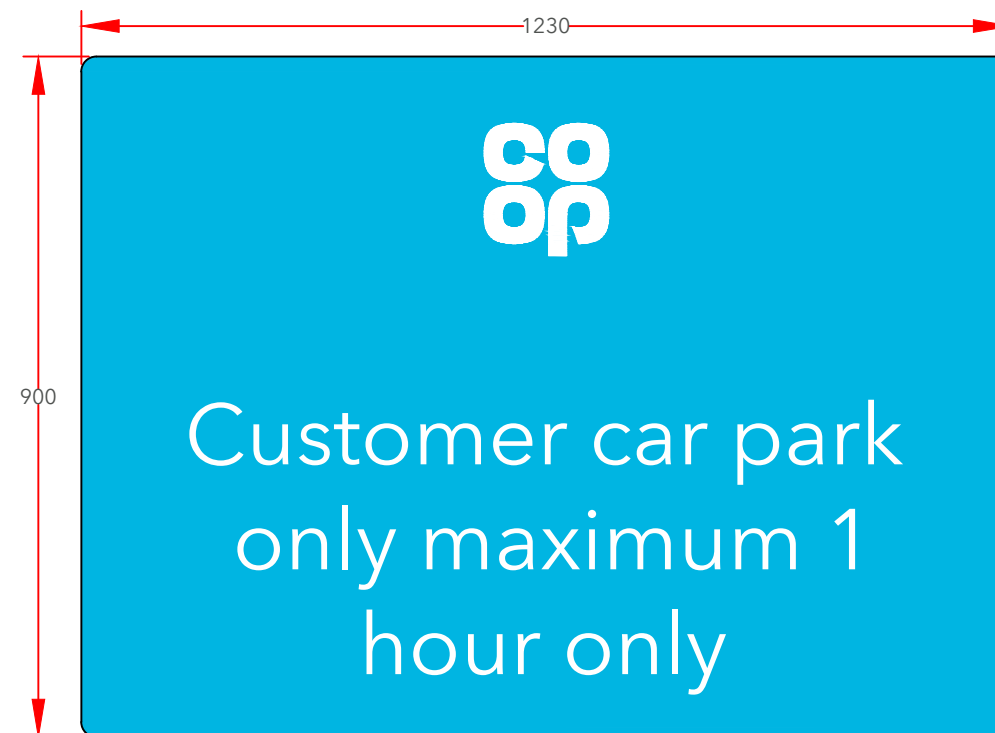

Sign G1 & G2 - Scale 1:10

900mm x 1230mm "Car parking" non-standard parking sign. 3mm ACM with applied vinyl display & anti-graffitti laminate. 20mm radius corners. Non-illuminated. (CFP-CP-129771 - G1 & G2) 1400mm H.A.G.L.

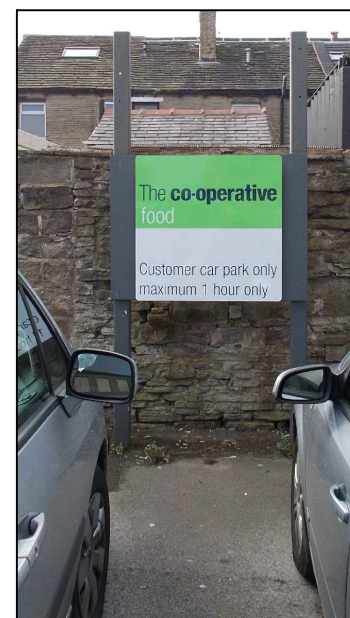

Existing

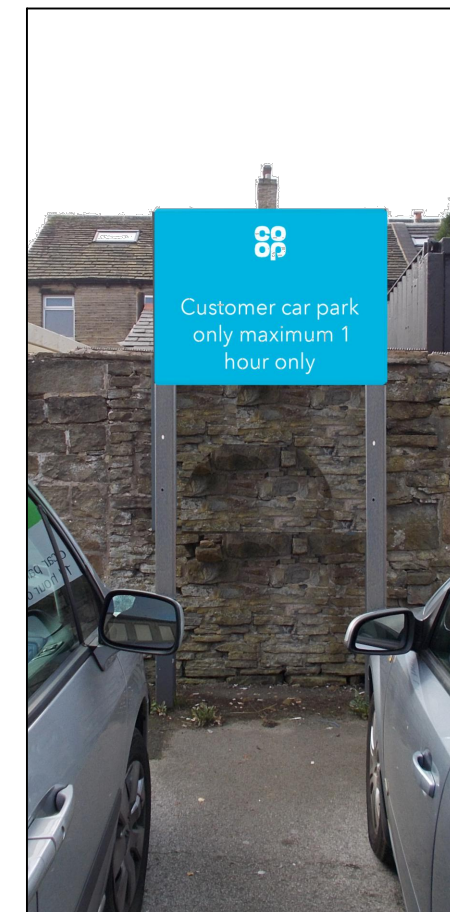

Proposed



Collections

Store Name: Meltham
 Store No: 7365
 Futurama W.O: 129771
 Store Type: Everyday Convenience - Mainstream
 Programme: Rollback
 CAD reference: N/A

Address: 18-24 Huddersfield Road
 Meltham Huddersfield
 West Yorkshire
 HD9 4AE
 Revision: -
 Original Scheme: AR

Olympia House
 Lockwood Court
 Middleton Grove
 Leeds
 LS11 5TY
 United Kingdom

Telephone: 0113 270 5595
 Facsimile: 0113 277 1143
 E-mail: postbox@futurama.ltd.uk

delivering
 branded
 environments™



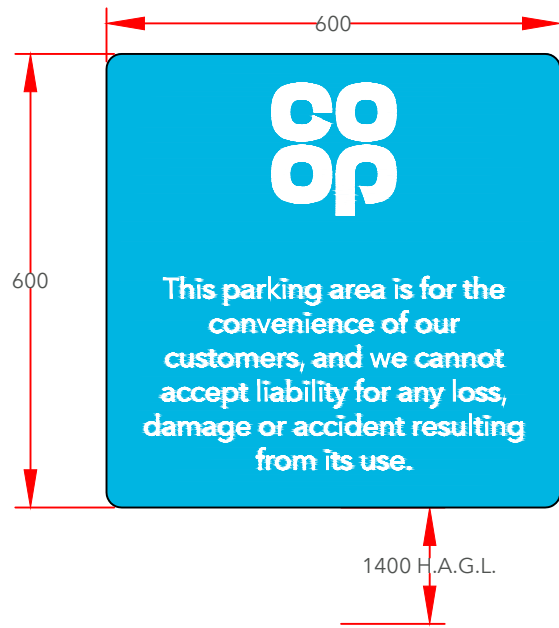

Signs H1, H2 & H3 - Scale 1:10

600mm x 600mm parking sign "Disclaimer".
3mm ACM with applied vinyl display &
anti-graffitti laminate. 20mm radius corners.
Non-illuminated. (CFP-CP-0600-I028)

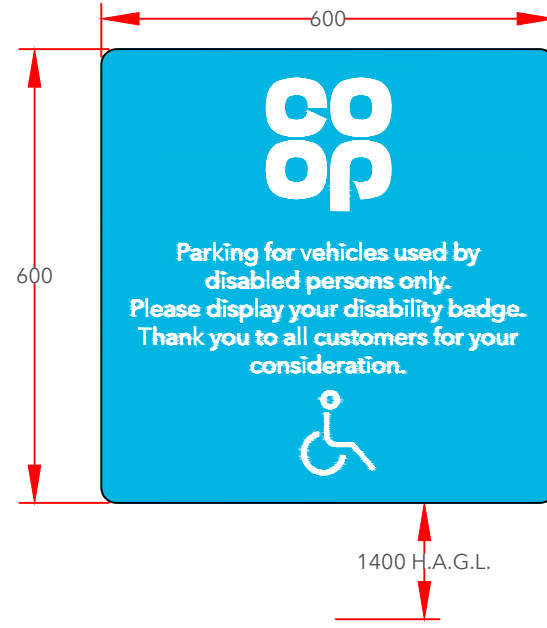

Sign I - Scale 1:10

600mm x 600mm parking sign "Disabled".
3mm ACM with applied vinyl display &
anti-graffitti laminate. 20mm radius corners.
Non-illuminated. (CFP-CP-0600-I030)



Sign J - Scale 1:10

600mm x 600mm parking sign "Goods
Delivery".
3mm ACM with applied vinyl display &
anti-graffitti laminate. 20mm radius corners.
Non-illuminated. (CFP-CP-0600-I031)

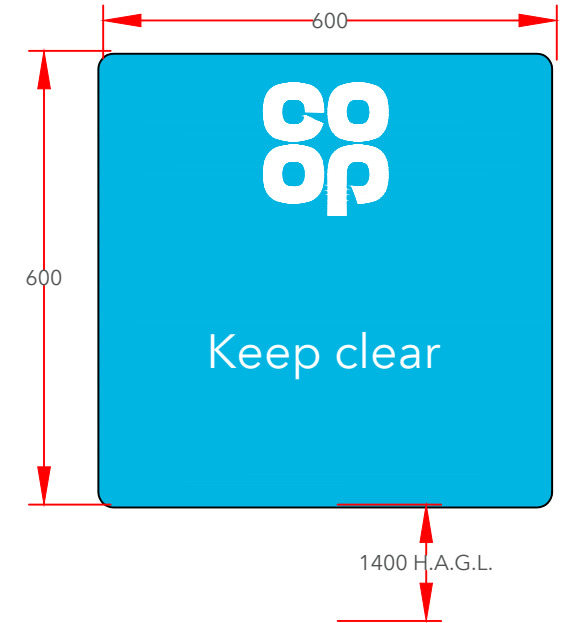

Sign K - Scale 1:10

600mm x 600mm parking sign "Keep Clear".
3mm ACM with applied vinyl display &
anti-graffitti laminate. 20mm radius corners.
Non-illuminated. (CFP-CP-0600-I029)



Collections

Store Name: Meltham
Store No: 7365
Futurama W.O: 129771
Store Type: Everyday Convenience - Mainstream
Programme: Rollback
CAD reference: N/A

Address: 18-24 Huddersfield Road
Meltham Huddersfield
West Yorkshire
HD9 4AE
Revision: -
Original Scheme: AR

Olympia House
Lockwood Court
Middleton Grove
Leeds
LS11 5TY
United Kingdom

Telephone: 0113 270 5595
Facsimile: 0113 277 1143
E-mail: postbox@futurama.ltd.uk



