

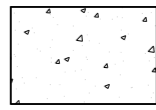
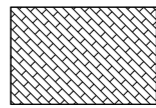
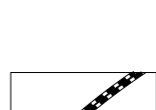

This drawing is not to be scaled. All dimensions to be checked on site. Discrepancies, ambiguities and/or omissions between this drawing & information given elsewhere must be reported immediately to this office for clarification before proceeding.

KEY HARDWORKS

-  Vehicular Tarmacadam surface
To Engineers Specification
-  **Block Paving - Light grey mix**
Marshalls La Liria (or similar approved)
Size: 300/200 x 200 x 80mm
Colour: 80% Light Granite, 20% Mid Grey Granite
Joints: 2-5mm Kln dried silica sand (to be confirmed)
Joint sealant - Resiblock Resilecco
Refer to drawing for laying details
-  **Paving Trim to match existing**
2no rows Marshalls La Liria (or similar approved)
Size: 100 x 100 x 80mm
Colour: Light Granite
Joints: 2-5mm Kln dried silica sand.
Refer to detail drawing for laying details
Sets adjacent to planting beds to be haunched in place.
-  **Composite Timber Deck Stage**
Ecodek Reversible Deck Board (or similar approved)
Size: 25 x 136mm x lengths to be approved
Colour: Slate Grey
Associated support beam and fixing details required
-  **Maintenance path**
Peagravel (or similar approved)
Size: 5-10mm
Colour: White
Geotextile membrane and appropriate surface preparation required

FURNITURE

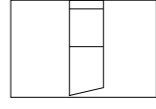
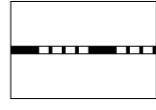
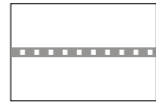
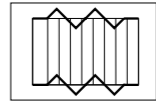
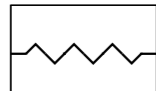

-  **Granite Seating**
Colour: Crystal Black
Other: To include anti skate recesses at 1m intervals
Refer to detail drawings for information
-  **Granite Coping**
Colour: Crystal Black
1000x200x95mm
Refer to detail drawings for information
-  **Granite Retaining Wall**
Hardscape Granite
Colour: Crystal Black
Finish: Flamed to all exposed surfaces
Refer to detail drawings for information
-  **Steps Details**
Hardscape Silver Grey Granite (or similar approved)
with inlaid contrasting visibility strip
Flame finished to all exposed surfaces
Steps feather out to suite site levels
-  **Hand Rail**
0.9-1.1m high stainless steel handrail
to comply Building Regs Part M & specific details.

-  **Litter Bin**
Stainless Steel finish

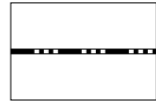
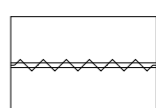
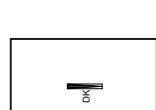
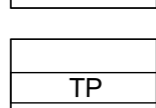
KERBS

-  **Textured Kerb**
Marshalls Conservation Kerb (or similar approved)
145 x 255mm
Colour: Standard aggregate
Refer to specification Q10: 110
-  **Textured Flush Kerb**
Marshalls Conservation (or similar approved)
145 x 255mm
Colour: Standard aggregate (or similar approved)
Refer to specification Q10: 110A
-  **Textured Transition Kerb**
Drop Kerb LH and RH as required
Colour: Standard aggregate (or similar approved)
Refer to Engineers specification for more information
-  **Hazard Warning Paving**
Tactile paving at road junctions (TP),
Corduroy at top and bottom steps (CP)
Hardscape Granite
Size: 2 x (400 x 400 x 50mm)
Colour: Kobra

SOFTWARES

-  **Location of Root Barrier**
Refer to Softworks details for information
-  **Proposed Trees**

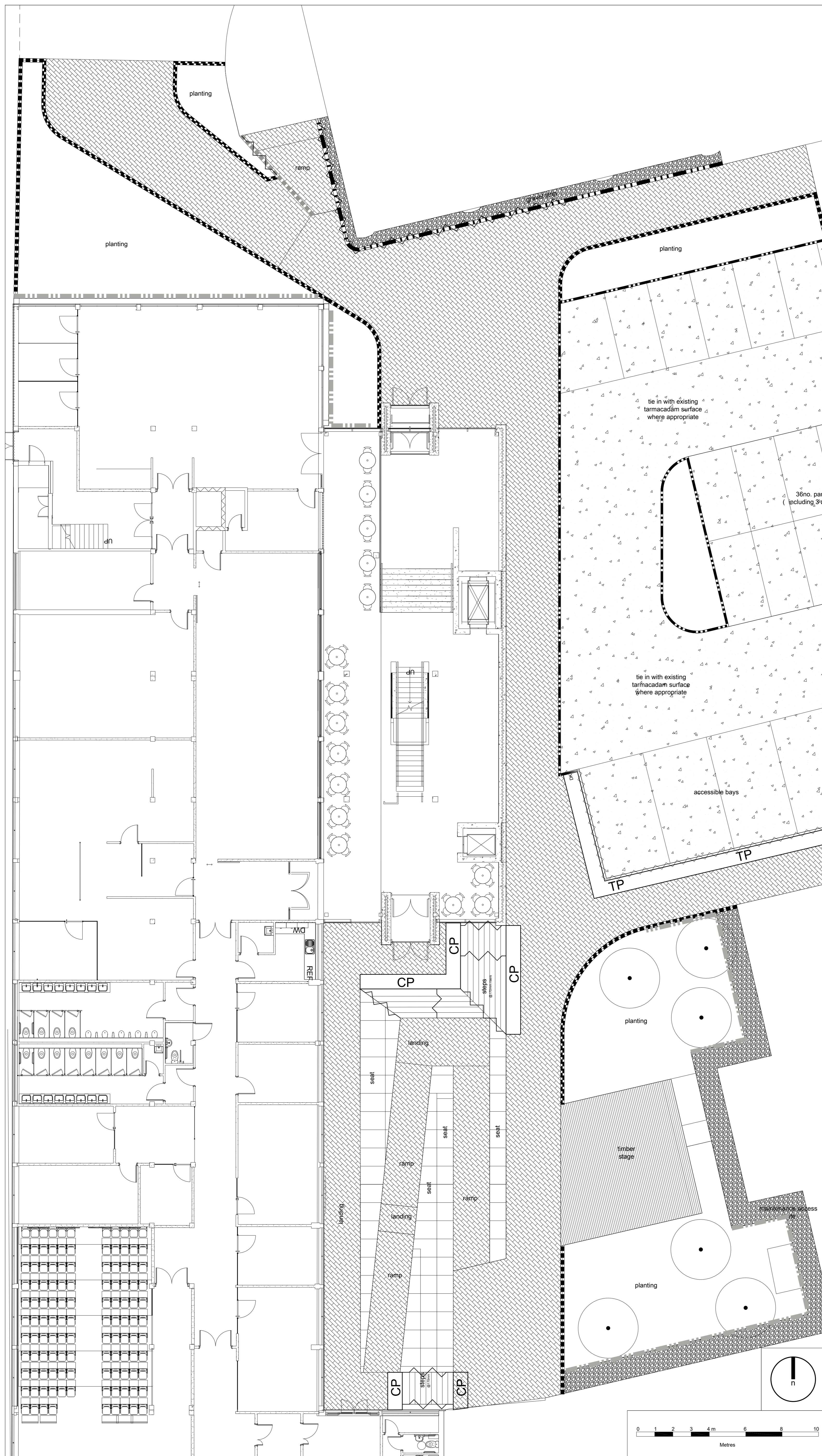

Tender Issue		TO	ST	MG	04/11/16
Revision		Rev	Drawn	Chkd	Date



Client AHR
 Project Joseph Priestley Building
 University of Huddersfield

Title General Arrangement
 Area Around Building

Dwg. No. AHR1296.GA.002 Scale 1:100@A1
 Revision TO Date November 2016

TENDER

