

**Client:** Mr. Rajan Gupta

Medipharm Bradford Ltd.

**Description:** Conversion of Existing Offices to form 21 No. Apartments.

**Address :** Wesley House, Chapel Lane, Birstall WF17 9EJ

**Planning Approval Ref :** 2024/62/92105/E  
**Condition 9 – External Lighting**

Designplan – Quantum semi recessed anti vandal 'eye lid' bulkhead light fitting fixed to building, to light downwards to avoid light pollution and to minimise effects on bats.



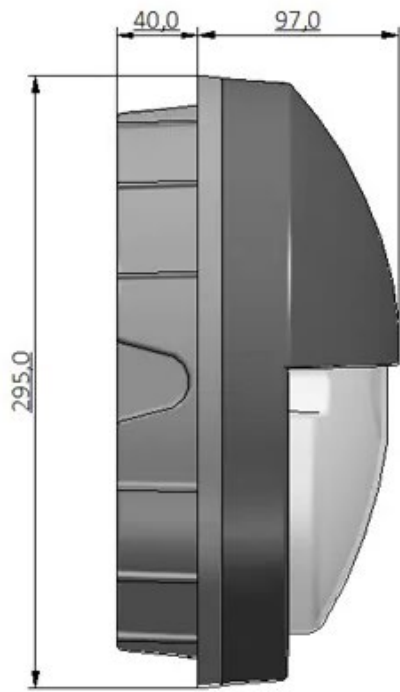

3m high column with LED Street Lantern to light downwards only to minimise light pollution and effects on bats.



## 3 METRE ROOT MOUNT COLUMN DRAWING

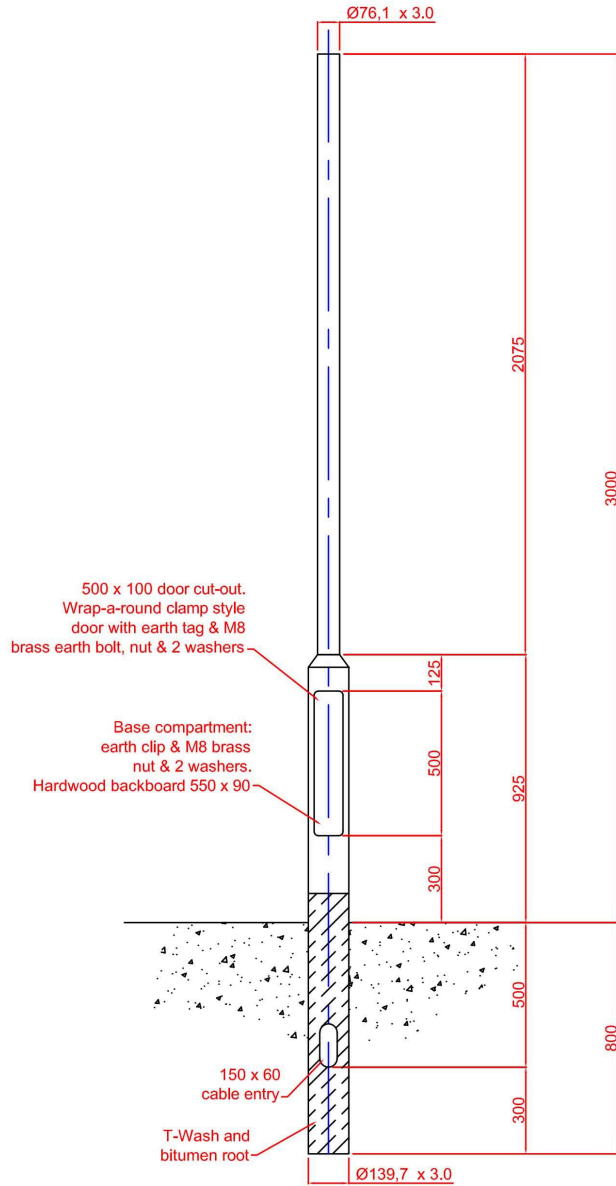

Material: BS EN 10219 or equivalent  
 Design: BS EN 40  
 Finish: Galvanise to BS EN 1461:1999  
 + external bitumen root  
 Welding: In accordance with BS 5135  
 Procedures to BS EN 288  
 Welders qualified to BS EN 287

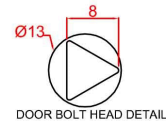



50W  
to  
200W

Floodlight to soffit of adjacent adjoined building

Site Plan Extract

