



JNP GROUP
CONSULTING ENGINEERS

SuDS Management and Maintenance Plan

Project: Turnbridge Mills, Quay Street,
Huddersfield

Client: John L Brierley Ltd.

Reference: S12097-JNP-XX-XX-RP-C-1002

Date: April, 2026

DOCUMENT CONTROL SHEET



Prepared by.....

Lee Carl
 BSc (Hons) MSc CEng MICE
 Associate Civil Engineer

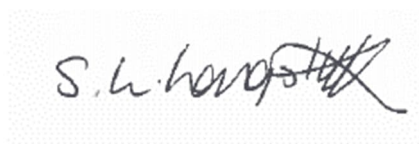

Approved by.....

Sarah Longstaff
 BSc (Hons) MSc FGS
 Associate

FOR AND ON BEHALF OF JNP GROUP

Date: April 2026

Document Issue Record

Rev	Date	Description	Prepared	Checked	Approved
P01	17/04/26	First Issue	LC	SLL	SLL
P02	20/05/26	Revised to include additional information on tanks and flow controls	LC	SLL	SLL

This document is for the sole use and reliance of JNP Group's Client and has been prepared in accordance with the scope of the appointment of JNP Group and is subject to the terms of that appointment.

JNP Group accepts no liability for any use of this document other than by its Client and only for the purposes for which it has been prepared.

No person other than the Client may copy (in whole or in part) or use the contents of this document, without the prior written permission of JNP Group.

Any advice, opinions or recommendations within this document should be read and relied upon only in the context of this document as a whole.

Any comments given within this document are based on the understanding that the proposed works to be undertaken will be as described in the introduction. The information referred to and provided by others and will be assumed to be correct and will not have been checked by JNP Group, JNP Group will not accept any liability or responsibility for any inaccuracy in such information.

Any deviation from the recommendations or conclusions contained in this document should be referred to JNP Group in writing for comment and JNP Group reserve the right to reconsider their recommendations and conclusions contained within. JNP Group will not accept any liability or responsibility for any changes or deviations from the recommendations noted in this document without prior consultation and our full approval.

Contents

1	INTRODUCTION	3
1.1	Terms of Reference	3
1.2	Site Description	3
1.3	Surface Water Drainage Strategy	3
1.4	Responsibility of Maintenance	3
2	SUDS MANAGEMENT AND MAINTENANCE REGIME	4
2.1	Proprietary Treatment Systems	4
2.2	Attenuation Storage Tanks	5
2.3	Pipe Networks, Gullies and Channel Drains	6
2.4	Hydrobrake Flow Control	7
3	RECORDS OF MAINTENANCE	8
APPENDIX A:	DRAINAGE DRAWINGS	9
APPENDIX B:	RECORDS OF MAINTENANCE	10
APPENDIX C:	SPEL OIL SEPARATOR MAINTENANCE REQUIREMENTS	11
APPENDIX D:	POLYSTORM TANK CDM REGULATIONS RISK ASSESSMENT AND METHOD STATEMENT FOR THE INSPECTION AND MAINTENANCE	12

List of Tables

Table 2-1:	Proprietary treatment system maintenance requirements	4
Table 2-2:	Attenuation storage tank maintenance requirements	5
Table 2-3:	Pipe network maintenance requirements	6
Table 2-4:	Gully and channel maintenance requirements	6
Table 2-5:	Flow control maintenance requirements	7

1 INTRODUCTION

1.1 Terms of Reference

1.1.1 JNP Group has been commissioned by John L Brierley Ltd to prepare a SuDS Management and Maintenance Plan for the proposed redevelopment of Turnbridge Mills, Quay Street, Huddersfield.

1.1.2 The purpose of this management plan is to demonstrate how the drainage system, including SuDS, will be maintained in compliance with various requirements and best practice guidance, including but not limited to, the National Planning Policy Framework (NPPF) and SuDS Manual (CIRIA 2015).

1.1.3 This management plan aims to:

- Summarise the drainage features used within the site.
- Establish who is responsible for the maintenance of the drainage components.
- Ensure that all those involved in the maintenance and operation of the SuDS understand their functionality and maintenance requirements in terms of supporting long-term performance.

1.2 Site Description

1.2.1 The project includes the redevelopment of a mixed use site including demolition of buildings; retention, conversion and renovations of existing mill buildings, workshops and engineer house buildings, erection of 2 new buildings, formation of 2 new vehicular access points and proposed service yard and parking areas.

1.2.2 The scheme has received planning approval under reference 2025/91122.

1.3 Surface Water Drainage Strategy

1.1.1 The surface water drainage system, detailed in Appendix B, consists of:

- Proprietary treatment systems – oil separators
- Attenuation storage tanks
- Pipe Network Under Road and Highway Gullies

1.4 Responsibility of Maintenance

1.4.1 Responsibility for the maintenance of the drainage network will be the landowner.

1.4.2 Only trained personnel shall be permitted to undertake maintenance works. This work must be carried out in accordance with the Confined Space Regulations where appropriate.

2 SUDS MANAGEMENT AND MAINTENANCE REGIME

2.1 Proprietary Treatment Systems

2.1.1 The manufacturer has provided maintenance requirements, included in Appendix C.

2.1.2 The recommended maintenance activities for the propriety treatment systems are outlined within Table 2-1.

Table 2-1: Proprietary treatment system maintenance requirements

Maintenance Schedule	Required Action	Recommended Frequency
Regular Maintenance	Remove litter and debris and inspect for sediment, oil and grease accumulation.	Half yearly
	Change the filter media.	As recommended by manufacturer
	Remove sediment, oil, grease and floatables.	As required – indicated by system inspections or immediately following significant spill
Remedial Actions	Replace malfunctioning parts or structures.	As required
Monitoring	Inspect for evidence of poor operation.	Half yearly
	Inspect filter media and establish appropriate replacement frequencies.	Half yearly
	Inspect sediment accumulation rates and establish appropriate removal frequencies.	Monthly during first half year of operation, then every half yearly

2.2 Attenuation Storage Tanks

- 2.2.1 The attenuation storage tank will be the responsibility of the landowner.
- 2.2.2 Before the attenuation storage tanks are handed over, they should be inspected for litter and debris. Inlets and outlets should also be inspected for any debris, plant growth or erosion. These inspections will be the responsibility of the developer, and all failures should be rectified by the developer.
- 2.2.3 Accumulated materials removed from the surface of the attenuation storage tank may exceed the total organic carbon criteria for hazardous waste and may need to be disposed of as controlled waste.
- 2.2.4 Waste disposal will be carried out by a competent contractor, who must hold the relevant permits to transport and dispose of the waste.
- 2.2.5 The recommended maintenance requirements for the attenuation storage tanks are outlined in Table 2-2.
- 2.2.6 Refer to Appendix D for a detailed CDM risk assessment and method statement for maintenance and inspection of the attenuation tanks.

Table 2-2: Attenuation storage tank maintenance requirements

Maintenance Schedule	Required Action	Recommended Frequency
Regular maintenance	Inspect and identify any areas that are not operating correctly. If required, take remedial action	Monthly for 3 months then annually
	Remove litter/debris from catchment surface	Monthly
	For systems where rainfall infiltrates into the tank above, check surface or filter for blockage by sediment, algae or other matter; remove and replace surface infiltration medium as necessary.	Annually
	Remove sediment from catchpit.	Annually, or as required
Remedial Actions	Repair/rehabilitate inlets, outlets, overflows and vents.	As required
Monitoring	Inspect/check all inlets, outlets and overflows to ensure that they are in good condition and operating as designed.	Annually
	Survey inside of tank for sediment build-up and remove if necessary.	Every 5 years or as required

2.3 Pipe Networks, Gullies and Channel Drains

2.3.1 Whilst the drainage system has been designed to operate with as little maintenance as possible, there are key operations that must regularly be undertaken to ensure that the system remains in optimal condition. The majority of these actions are routine and should be carried out upon all drainage systems.

2.3.2 The pipe networks, gullies and channels will be the responsibility of the landowner.

2.3.3 Litter picking at the site should be frequent to prevent rubbish limiting the effective operation of components such as the catchpits. This will reduce the frequency with which the system has to be cleaned out.

2.3.4 The recommended maintenance requirements for these elements are outlined below in Table 2-3 and Table 2-4.

Table 2-3: Pipe network maintenance requirements

Maintenance Schedule	Required Action	Recommended Frequency
Regular Maintenance Occasional Maintenance	Check the drains for blockages and damage. Clean and repair if required.	Monthly for the first 3 months of installation. Then every 6 months.
	Remove sediment from catchpits.	Annually or after large storm events.
Remedial Actions	Jetting of pipework to clear blockages.	As required.
Monitoring	Inspect for evidence of poor operation and/or damage at manholes etc.	Monthly for the first 3 months and then annually.
	Inspect inlets and outlets for blockages, and clear as required.	Annually.

Table 2-4: Gully and channel maintenance requirements

Maintenance Schedule	Required Action	Recommended Frequency
Regular Maintenance	Check for blockages and damage. Clean and repair if required.	Monthly for the first 3 months of installation. Then every 6 months.
Occasional Maintenance	Desilting gullies and channel drains.	As required.
	Grating on gullies and channel drains to be kept clear of debris.	As required or after large storm events.
Monitoring	Remove sediment from gullies catchpits.	Annually or after large storm events.
	Inspect for evidence of poor operation of gullies.	Monthly for the first 3 months and then annually.

2.4 Hydrobrake Flow Control

2.4.1 The flow control chambers, including the Hydro-Brake vortex flow control device, will be the responsibility of the landowner.

2.4.2 Hydro-Brake vortex flow control devices are passive systems with no moving parts, requiring minimal maintenance under normal conditions. However, regular inspection of the chamber is essential to ensure that debris, silt or upstream blockages do not impair performance, as blockages at the inlet are the primary maintenance risk for vortex controls.

2.4.3 Routine maintenance generally consists of inspection and removal of debris, with more intrusive works only required if a blockage is suspected.

2.4.4 The recommended maintenance requirements for these elements are outlined below in Table 2-5.

Table 2-5: Flow control maintenance requirements

Maintenance Schedule	Required Action	Recommended Frequency
Regular Maintenance	Inspect flow control chamber for debris, silt build up or blockage at inlet	Monthly for first 3 months, then every 6 months
	Remove debris, silt or obstructions from chamber and upstream catchpit	As required (typically 6 monthly or after storm events)
	Check operation of bypass mechanism / rodding access (if provided)	Annually
Occasional Maintenance	Jet upstream/downstream pipework to remove blockages (avoid excessive pressure)	As required
	Drain down chamber and visually inspect unit condition	As required
Remedial Actions	Remove and clean flow control if blockage suspected	As required.
	Repair or replace damaged fixings, seals or components	As required
Monitoring	Inspect flow control chamber, inlets and outlets for correct operation	Annually.
	Check for evidence of surcharge, poor discharge or backing up of system	Annually.
	Full inspection of internal condition (via CCTV or confined entry if necessary)	Every 5 years or as required

3 RECORDS OF MAINTENANCE

3.1.1 Please provide a record of all inspections (including photographic evidence) in Appendix B.

APPENDIX A: DRAINAGE DRAWINGS

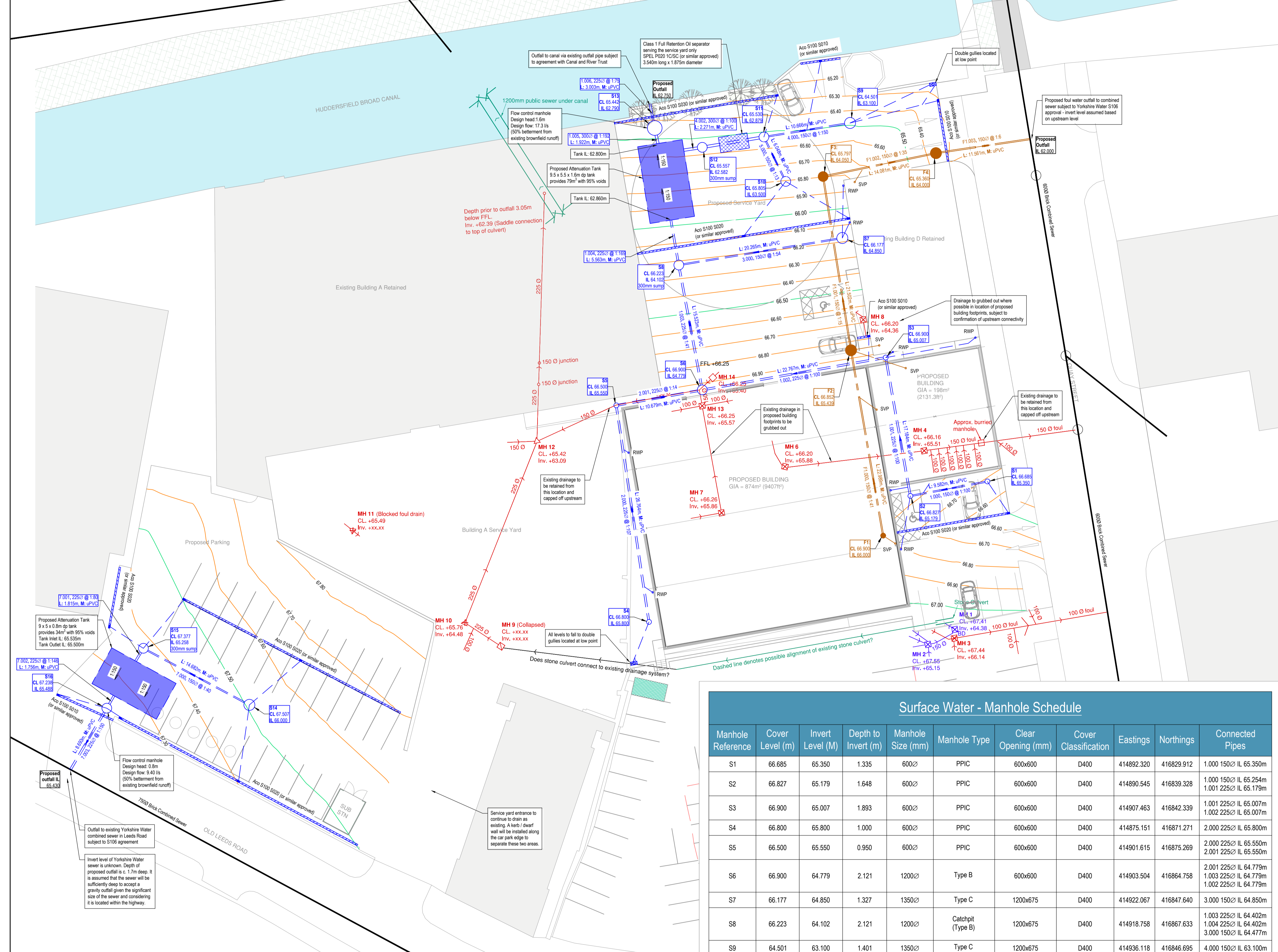
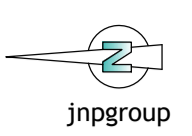

Private Drainage Notes

- This drawing is to be read in conjunction with and checked against all other drawings, engineering details, specification and any structural, geotechnical or other specialist documents provided.
- All lateral connections for house drainage shall be 100mm unless stated otherwise and must extend a minimum of 500mm behind the back of the footpath.
- All pipes to be vitrified clay or UPVC and shall be 100mmØ laid to a fall of 1:80 unless noted otherwise or indicated by size and invert levels. All connections when laid shall be plugged, protected as necessary and marked with a stake for future use.
- Building drainage shall comply with BS 8301 1985, BS EN 752 and Building Regulations Part H. Inspection chambers located within garages to have double seal bolt down covers.
- Gully top and manhole cover specification to be in accordance with BS EN 124 and located in accordance with the intended use and loading classification as described within groups 1-6:
- This drawing is schematic for clarity only, positions of pipe runs and manholes may vary on site due to site conditions.
- Connections to pre-formed inspection chamber bases should ensure the main channel is used in all cases. High velocity discharges (e.g. from SVPs) should use the main channel where practicable.
- Cover and invert levels are indicative and may vary on site. In any case the following minimum cover to depth of cover to the crown of pipes without protection shall be as follows:
 - Domestic gardens and pathways without any possibility of vehicular access - 0.35m
 - Domestic driveways, parking areas and yards with height restrictions to prevent entry by vehicles with a gross weight in excess of 7.5 tonnes - 0.5m
 - Domestic driveways, parking areas and narrow streets without footways (e.g. Mews developments) with limited access for vehicles with a gross weight in excess of 7.5 tonnes - 0.9m
 - Agricultural land and public open space - 0.9m
 - Other highways and parking areas with unrestricted access to vehicles with a gross weight in excess of 7.5 tonnes - 1.2m

Health & Safety Note

The details on this drawing have been prepared on the assumption that a competent contractor will be carrying out the works. If the contractor(s) considers that there is insufficient Health and Safety information on this drawing, this should immediately be brought to the attention of the designer.

Drainage Legend

- Existing public combined sewer taken from records
 - Existing private combined/foul drainage as surveyed
 - Existing private surface water drainage as surveyed
 - Existing stone culverts
 - New private foul water drainage
 - New private soil and vent pipe
 - New private surface water drainage
 - New private yard gully
 - New private channel drain
 - New private rain water pipe
 - New cellular crate attenuation tank
 - New oil separator tank
- Note: In-situ concrete used in connection with a) and b) above shall be standard mix GEN3 in accordance with BS 5328.
- Note: Existing surveyed drainage is taken from TD Jagger Existing Drainage Plan drawing 3310 100

Surface Water - Manhole Schedule

Manhole Reference	Cover Level (m)	Invert Level (M)	Depth to Invert (m)	Manhole Size (mm)	Manhole Type	Clear Opening (mm)	Cover Classification	Eastings	Northings	Connected Pipes
S1	66.685	65.350	1.335	600Ø	PPIC	600x600	D400	414892.320	416829.912	1.000 150Ø IL 65.350m
S2	66.827	65.179	1.648	600Ø	PPIC	600x600	D400	414890.545	416839.328	1.000 150Ø IL 65.254m 1.001 225Ø IL 65.179m
S3	66.900	65.007	1.893	600Ø	PPIC	600x600	D400	414907.463	416842.339	1.001 225Ø IL 65.007m 1.002 225Ø IL 65.007m
S4	66.800	65.800	1.000	600Ø	PPIC	600x600	D400	414875.151	416871.271	2.000 225Ø IL 65.800m
S5	66.500	65.550	0.950	600Ø	PPIC	600x600	D400	414901.615	416875.269	2.000 225Ø IL 65.550m 2.001 225Ø IL 65.550m
S6	66.900	64.779	2.121	1200Ø	Type B	600x600	D400	414903.504	416864.758	2.001 225Ø IL 64.779m 1.003 225Ø IL 64.779m 1.002 225Ø IL 64.779m
S7	66.177	64.850	1.327	1350Ø	Type C	1200x675	D400	414922.067	416847.640	3.000 150Ø IL 64.850m
S8	66.223	64.102	2.121	1200Ø	Catchpit (Type B)	1200x675	D400	414918.758	416867.633	1.003 225Ø IL 64.402m 1.004 225Ø IL 64.402m 3.000 150Ø IL 64.477m
S9	64.501	63.100	1.401	1350Ø	Type C	1200x675	D400	414936.118	416846.695	4.000 150Ø IL 63.100m
S10	65.805	63.500	2.305	1200Ø	Type B	600x600	D400	414928.978	416854.563	5.000 150Ø IL 63.500m
S11	65.530	62.879	2.651	1200Ø	Type B	600x600	D400	414934.410	416857.223	5.000 150Ø IL 63.029m 4.000 150Ø IL 63.029m 4.001 300Ø IL 62.879m
S12	65.557	62.582	2.975	1200Ø	Catchpit (Type B)	600x600	D400	414933.144	416864.761	4.002 300Ø IL 62.882m 4.001 300Ø IL 62.882m
S13	65.442	62.790	2.652	1800Ø	Type B	600x600	D400	414935.501	416870.566	1.005 300Ø IL 62.790m 1.006 225Ø IL 62.790m
S14	67.507	66.000	1.507	1350Ø	Type C	1200x675	D400	414865.017	416920.105	7.000 150Ø IL 66.000m
S15	67.377	65.258	2.119	1200Ø	Catchpit (Type B)	1200x675	D400	414871.932	416933.056	7.000 150Ø IL 65.633m 7.001 225Ø IL 65.558m
S16	67.238	65.488	1.750	1200Ø	Type B	1200x675	D400	414864.615	416937.535	7.003 225Ø IL 65.488m 7.002 225Ø IL 65.488m

Foul Water - Manhole Schedule

Manhole Reference	Cover Level (m)	Invert Level (M)	Depth to Invert (m)	Manhole Size (mm)	Manhole Type	Clear Opening (mm)	Cover Classification	Eastings	Northings	Connected Pipes
F1	66.900	66.000	0.900	600Ø	PPIC	600x600	D400	414885.702	416842.652	F1.000 150Ø IL 66.000m
F2	66.852	65.439	1.413	1350Ø	Type C	1200x675	D400	414908.352	416846.584	F1.000 150Ø IL 65.439m F1.001 150Ø IL 65.439m
F3	65.797	64.050	1.747	1200Ø	Type B	600x600	D400	414929.582	416849.993	F1.001 150Ø IL 64.050m F1.002 150Ø IL 64.450m
F4	65.360	64.000	1.360	1350Ø	Type C	1200x675	D400	414932.438	416836.205	F1.002 150Ø IL 64.050m F1.003 150Ø IL 64.000m

Rev.	Date	Description	Drawn By	Checked By
P01	28/11/2025	Draft Issue		LC/CS

S3 - Suitable for Review & Comment

JNP GROUP
CONSULTING ENGINEERS

Amersham • Belfast • Brighouse • Bristol
Hartlepool • Sheffield • Warwick

www.jnpgroup.co.uk

Client: **John L Brierley Ltd.**

Job: **Turnbridge Mills, Quay Street, Huddersfield**

Title: **Proposed Drainage Layout**

Classification: **FL 60_20**

Scale @ A1: **1:250**

Project - Originator - Valuation System - Level/Location - Type - Discipline - Number: **S12097 - JNP-XX-XX-DR-C-2005**

Revision: **P01**

Diameter of Largest Pipe in Manhole (mm)	Internal Diameter of Manhole (mm)
300 Filter Drains	900
Less than 375	1200
500 to 700	1500
750 to 900	1800
Greater than 900	Pipe diameter + 900

Nominal Diameter of Pipe (mm)	Effective Length (m)
150 to 600	0.6
600 to 750	1.0
700 and over	1.25

Nominal Diameter of Pipe (mm)	Thickness of Compressible Filler (mm)
Less than 450	18
450 - 1200	36
Exceeding 1200	54

Note:
a = 3 but with a min. of 200mm around the barrels and a min. of 150mm around the sockets

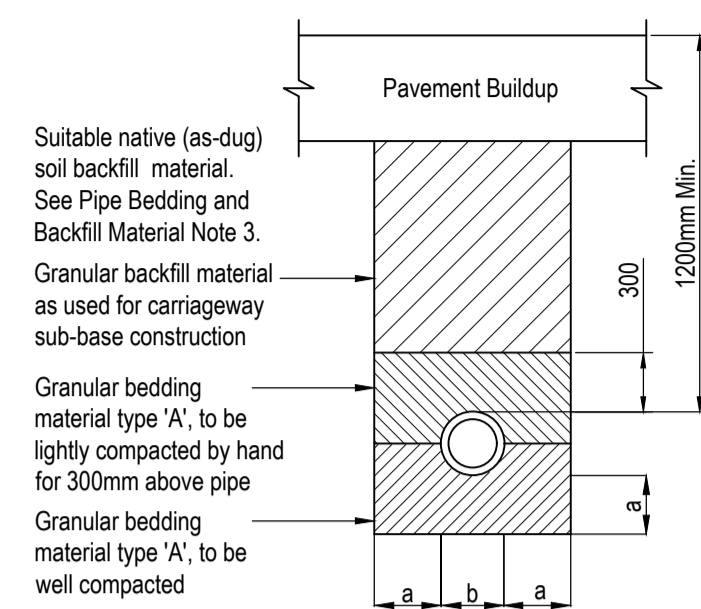

Under Carriageway or Footway

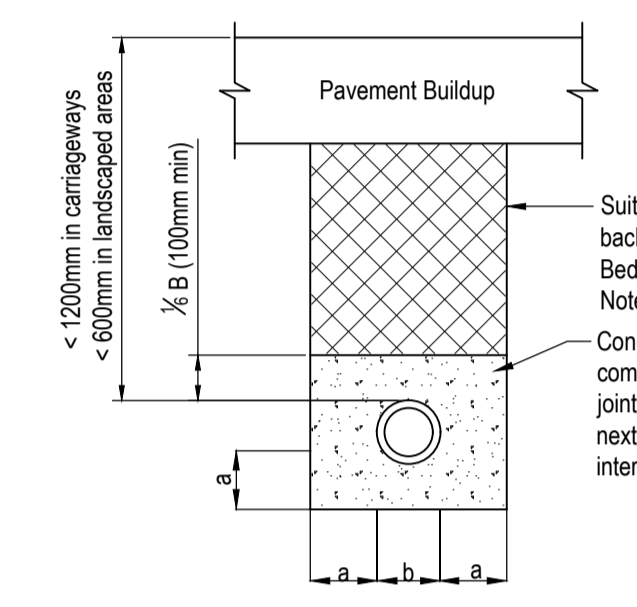

Drainage Shallow Pipe Bedding Detail

Pipe Bedding and Backfill Material Notes

1. Material designated type 'A' shall consist of angular gravel or crushed rock graded in accordance with BS 882, or air cooled blast furnace slag to BS 1047, or sintered pulverised fuel ash to BS 3797, selected according to pipe size as follows:-

Nominal Size of Pipes (mm)	Maximum Particle Size (mm)	Imported Granular Materials
100	10	10mm nominal single-size
Over 100 to 150	15	10 or 14mm nominal single-size or 14mm to 5mm graded
Over 150 to 300	20	10, 14 or 20mm nominal single-size or 14mm to 5mm graded or 20mm to 5mm graded
Over 300 to 600	20	14 or 20mm nominal single-size or 14mm to 5mm graded or 20mm to 5mm graded or 40mm to 5mm graded
Over 600	40	14, 20 or 40mm single-size or 14mm to 5mm graded or 20mm to 5mm graded or 40mm to 5mm graded

2. Material designated type 'B' shall consist of suitable native soil (see note 3), graded according to pipe size as follows:

Nominal Size of Pipes (mm)	Maximum Particle Size (mm)
200 or less	22
201 to 600	40
Over 600	60

Note: for pipes with nominal diameter of less than 100mm, all written instructions of the manufacturer shall be complied with.

3. Suitable Native (as-dug) Soil shall consist of uniform, readily compactable material, free from oversized particles, tree roots, waste, organic material, snow and ice, and exclude clay lumps larger than 75mm, as per BS EN 1610:2015 Cl. 5.2 and 5.3. Material to be compacted in 225mm layers.

Note:
At each flexible pipe joint a joint filler (e.g. fibreboard or polystyrene) shall be used (see table below), and shall extend through the full thickness of any concrete in contact with the pipe. The concrete bed shall be cut away at each joint to give a clearance of at least 50mm, so that the joint does not bear on the bed.

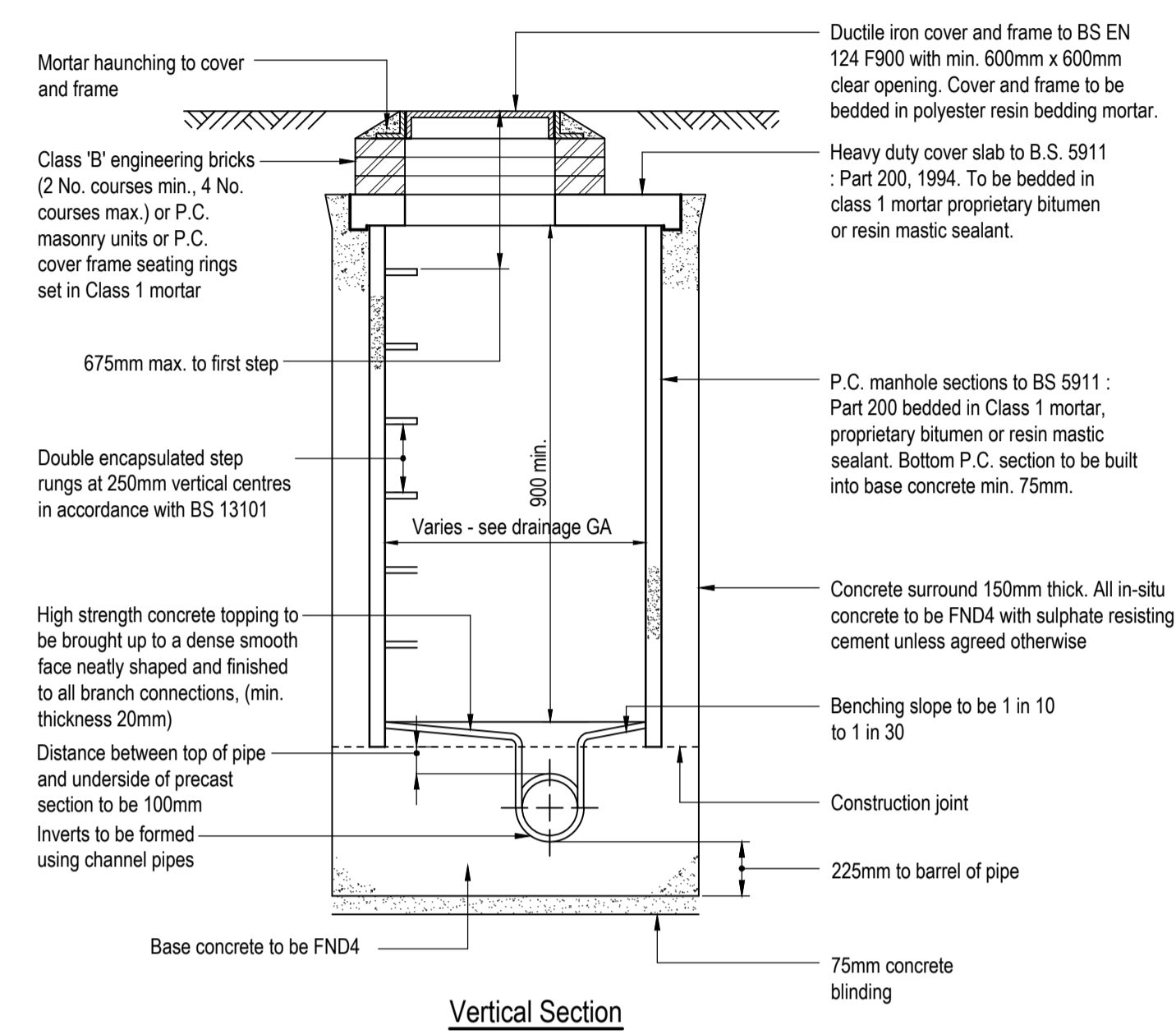

Vertical Section

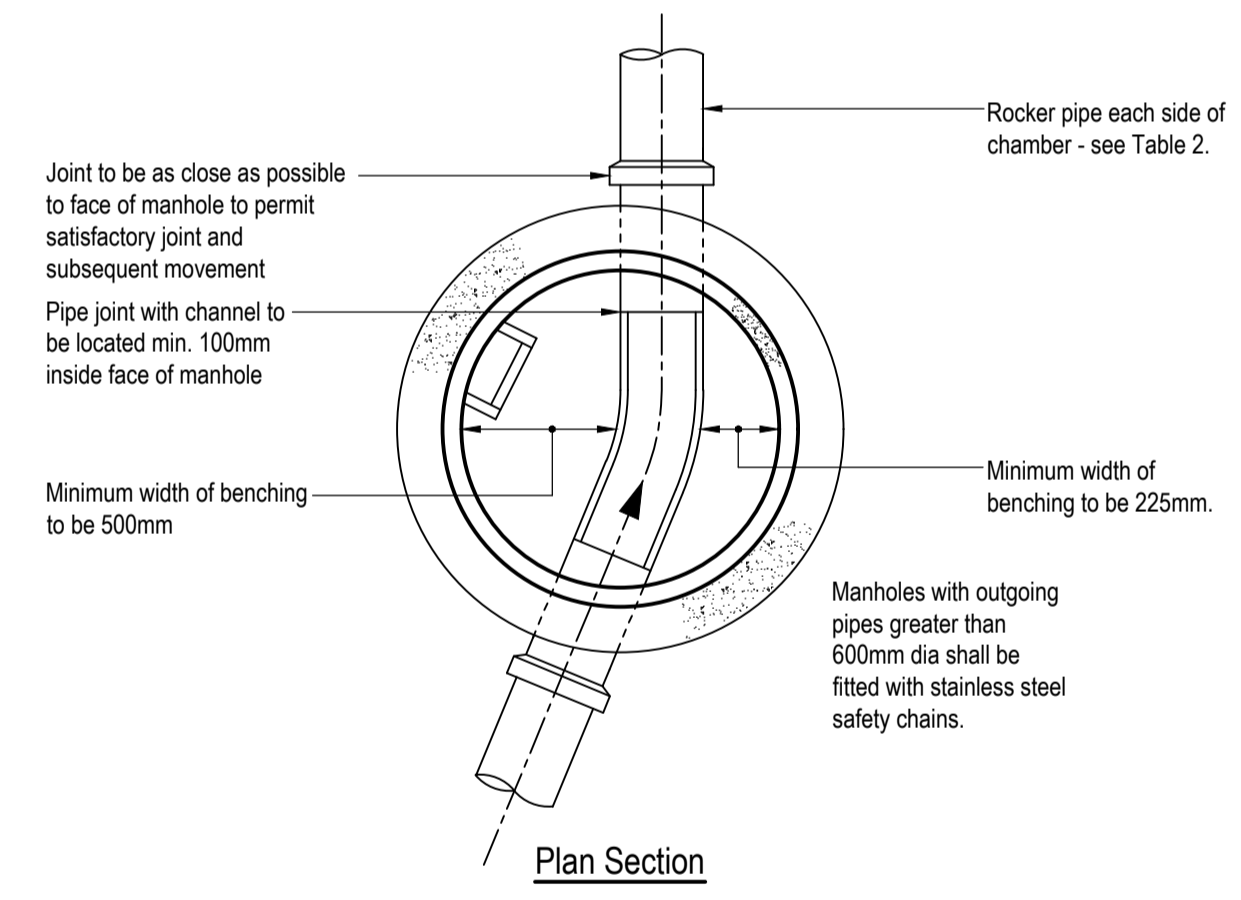

Plan Section

Typical Manhole Detail - Type B
Depth from ground level to soffit of pipe 1.5m - 3.0m
(Scale: 1:25)

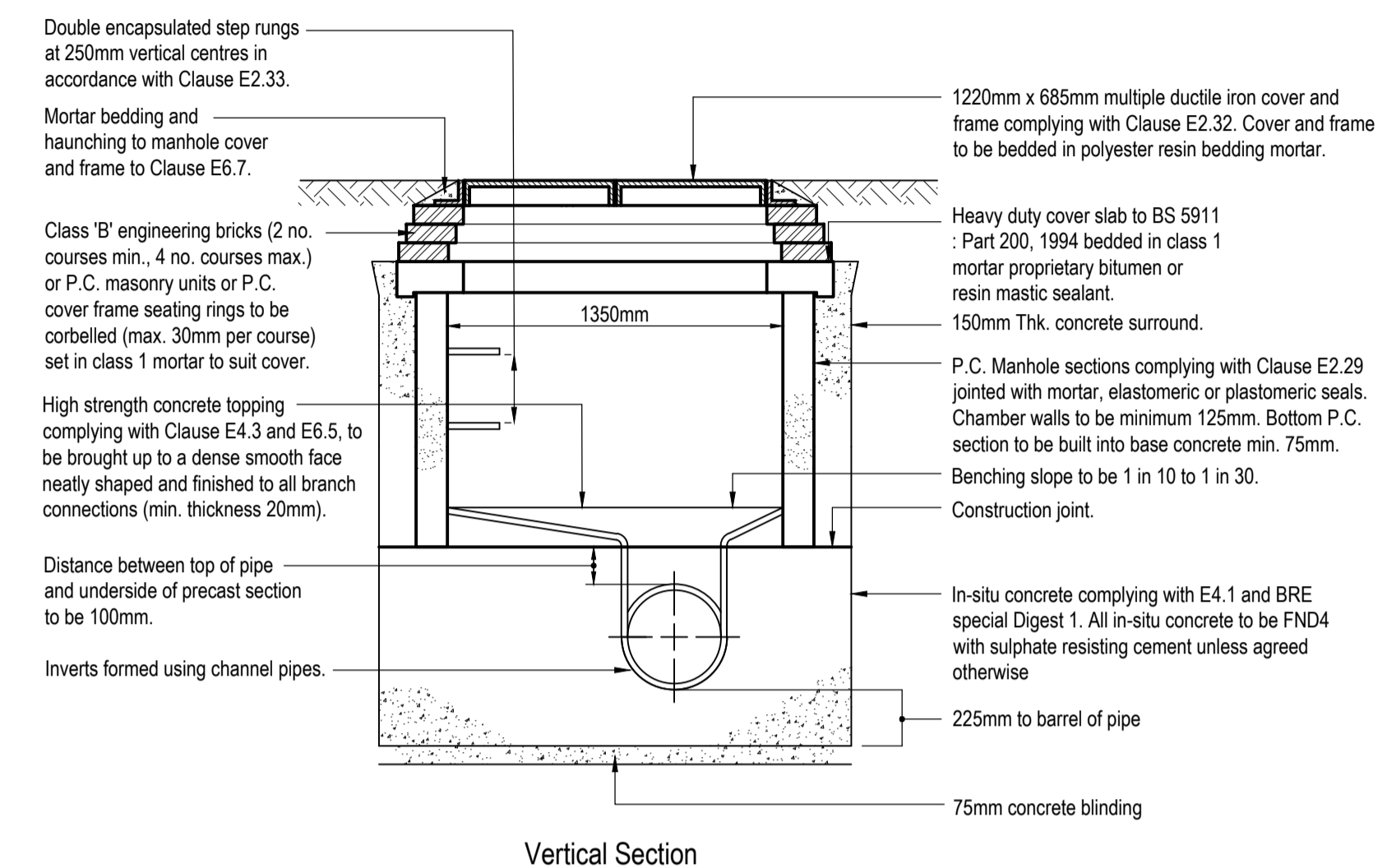

Vertical Section

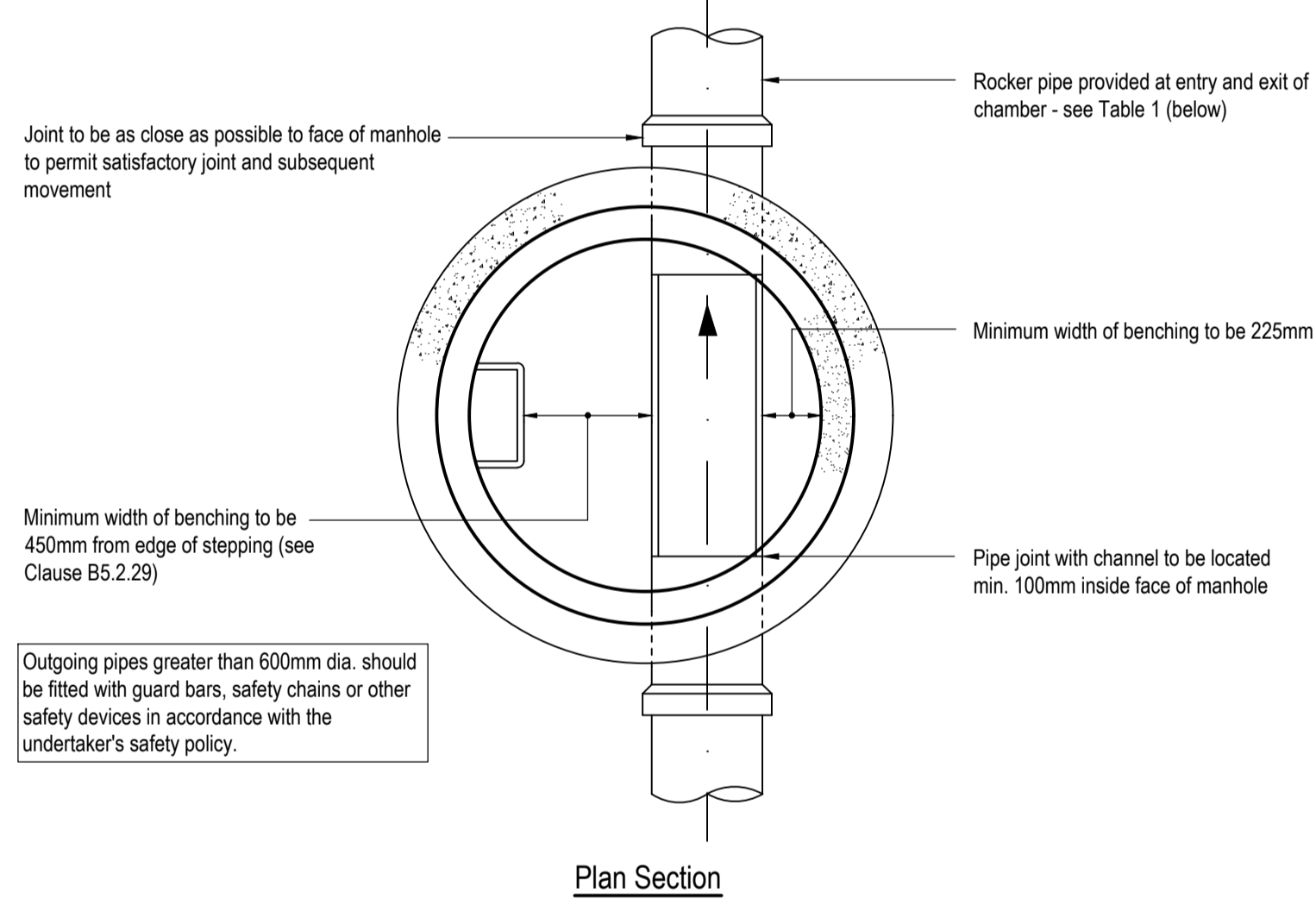

Plan Section

Typical Manhole Detail - Type C
Depth from ground level to soffit of pipe 1.0m - 1.5m
(Scale: 1:25)

Pipe Bedding Details
(Scale 1:25)

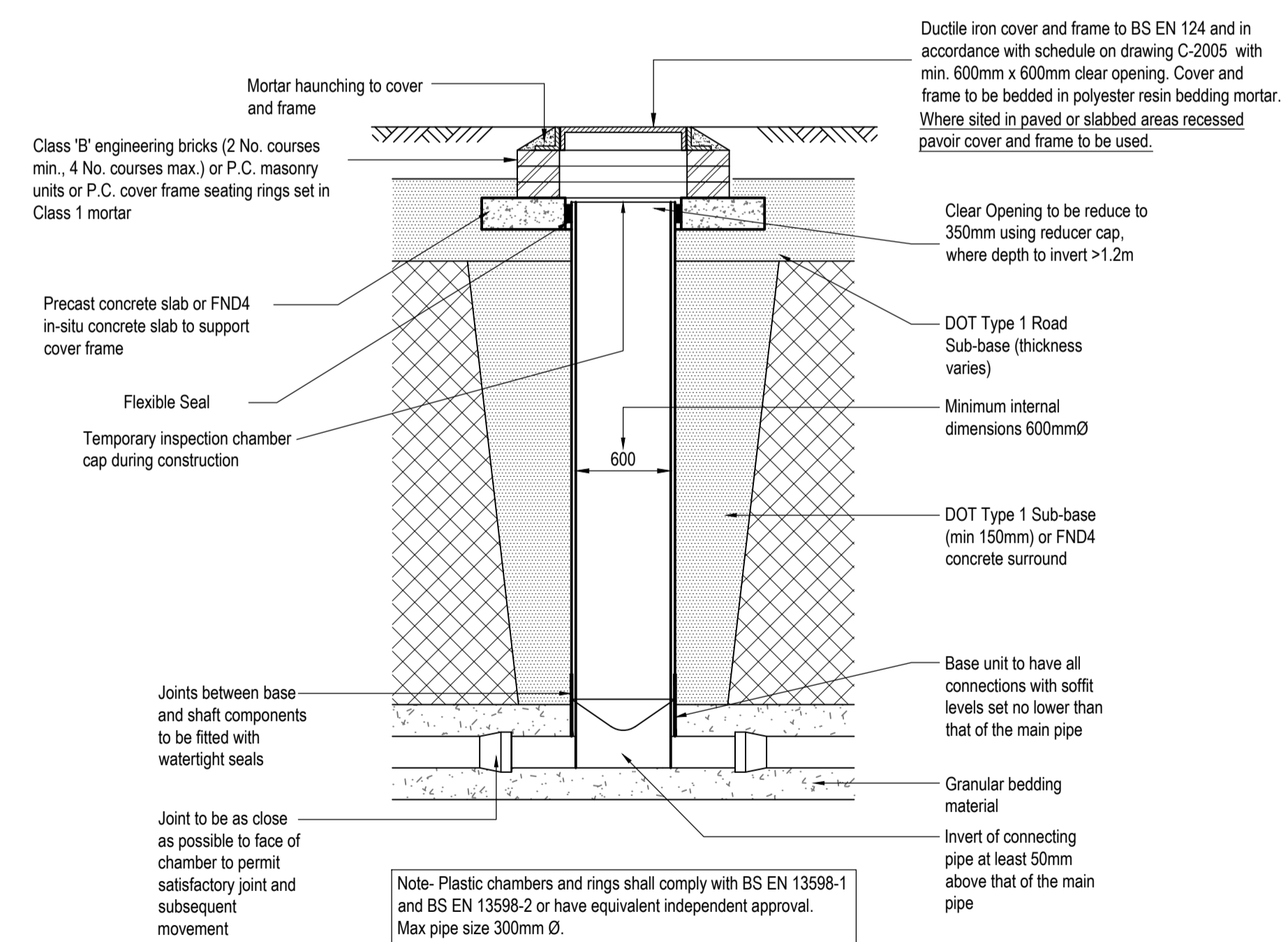

Note- Plastic chambers and rings shall comply with BS EN 13598-1 and BS EN 13598-2 or have equivalent independent approval. Max pipe size 300mm Ø.

600mm Dia Inspection Chamber detail (Flexible Material) in areas subject to vehicle loading
(Max depth 3m)
Scale 1:25

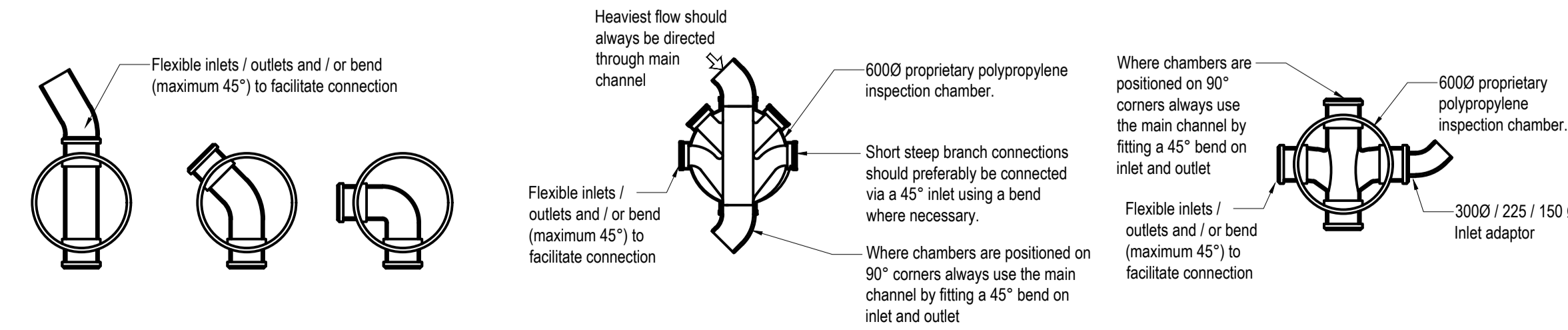

Alternative Base Layouts For 600mm Dia Inspection Chambers

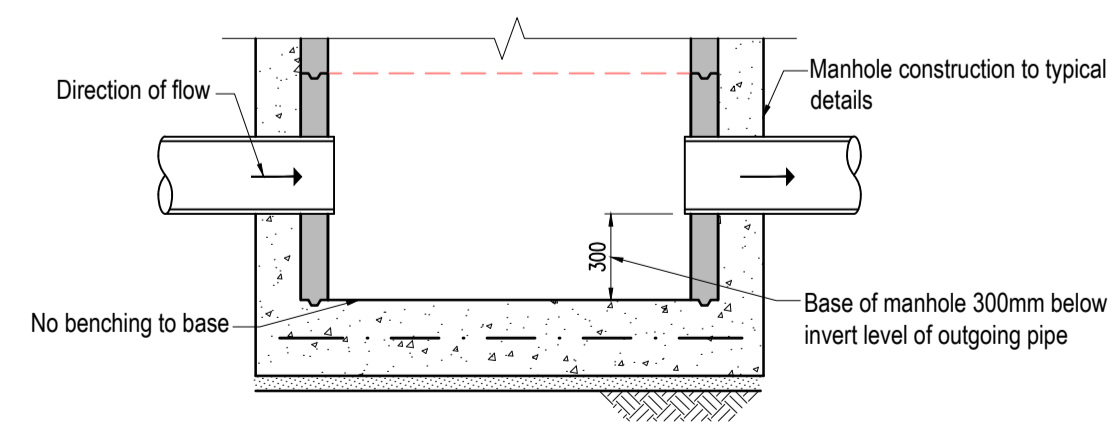

Typical Catchpit Manhole Detail - Type B
Scale: 1:25

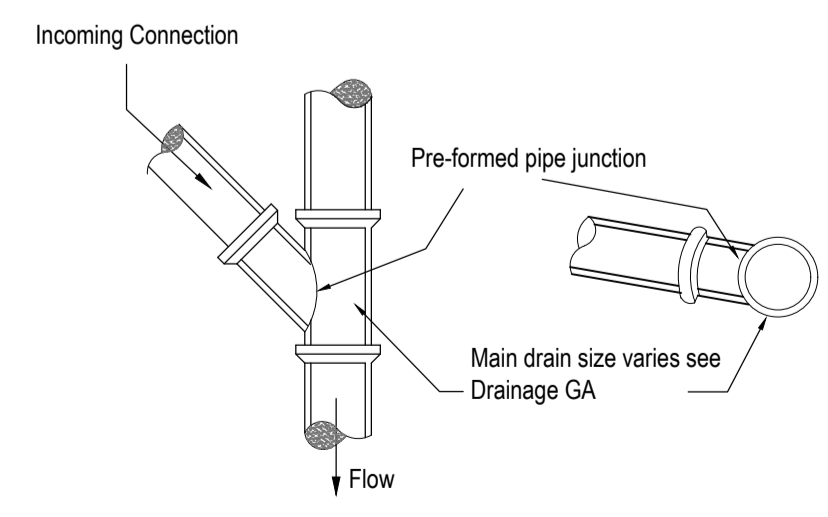

Typical 'Y' Junction Connection
(Scale 1:25)

General Notes

- Where this drawing has been issued in electronic .dwg format, it has been done so in good faith. JNP Group do not take any responsibility for any inaccuracies in the electronic data, which should be checked against the paper (or .pdf) drawing issue. Any apparent discrepancies should be immediately reported to JNP Group. The electronic .dwg file should not be assumed to be to scale and should not be used for 'overlying', setting out or checking of any third party information. All dimensions should be taken from the paper (or .pdf) version of the drawing. Electronic drawings may contain third party information. JNP Group take no responsibility for this information, which should be checked against the originators paper drawing(s).
- All dimensions are millimetres (mm), and levels are in metres (m) unless noted otherwise and should be checked on site prior to construction/fabrication.
- Do not scale from this drawing. Only figured dimensions are to be relied upon. Don't hesitate to get in touch with JNP Group if additional information is required.
- Any discrepancies between drawings of different scales and between drawings and specifications, where appropriate, to be reported to JNP Group for decision.
- Copyright reserved. This drawing may only be used for The Client and location specified in the title block. It may not be copied or disclosed to any third party without the prior written consent of JNP Group.
- This drawing should only be used for construction if the drawing status is "A4 - Approved/Stage Complete". JNP Group takes no responsibility for construction works undertaken to drawings that are not marked with this status.

Health & Safety Note
The details on this drawing have been prepared on the assumption that a competent contractor will be carrying out the works. If the contractor(s) considers that there is insufficient Health and Safety information on this drawing, this should immediately be brought to the attention of the designer.

Rev.	Date	Description	Drn / Chk / Appr.
P01	28/11/2025	Draft Issue	LC / CS

Submittal: S3 - Suitable for Review & Comment

JNP GROUP
CONSULTING ENGINEERS
Amersham • Belfast • Brighouse • Bristol
Hartlepool • Sheffield • Warwick
www.jnpgroup.co.uk

Client: John L Brierley Ltd.
Job: Turnbridge Mills, Quay Street, Huddersfield
Title: Drainage Details Sheet 1 of 2
Classification: FI_60_20
Scale @ A1: As Shown
Project - Originator - Volume/System - Level/Location - Type - Discipline - Number: S12097 - JNP - XX-XX-DR - C - 3001
Revision: P01

- Where this drawing has been issued in electronic .dwg format, it has been done so in good faith. JNP Group do not take any responsibility for any inaccuracies in the electronic data, which should be checked against the paper (or .pdf) drawing issue. Any apparent discrepancies should be immediately reported to JNP Group. The electronic .dwg file should not be assumed to be scale and should not be used for 'overlying', setting out or checking of any third party information. All dimensions should be taken from the paper (or .pdf) version of the drawing. Electronic drawings may contain third party information. JNP Group take no responsibility for this information, which should be checked against the originators paper drawing(s).
- All dimensions are millimetres (mm), and levels are in metres (m) unless noted otherwise and should be checked on site prior to construction/fabrication.
- Do not scale from this drawing. Only figured dimensions are to be relied upon. Don't hesitate to get in touch with JNP Group if additional information is required.
- Any discrepancies between drawings of different scales and between drawings and specifications, where appropriate, to be reported to JNP Group for decision.
- Copyright reserved. This drawing may only be used for The Client and location specified in the title block. It may not be copied or disclosed to any third party without the prior written consent of JNP Group.
- This drawing should only be used for construction if the drawing status is "A4 - Approved/Stage Complete". JNP Group takes no responsibility for construction works undertaken to drawings that are not marked with this status.

Health & Safety Note
 The details on this drawing have been prepared on the assumption that a competent contractor will be carrying out the works. If the contractor(s) considers that there is insufficient Health and Safety information on this drawing, this should immediately be brought to the attention of the designer.

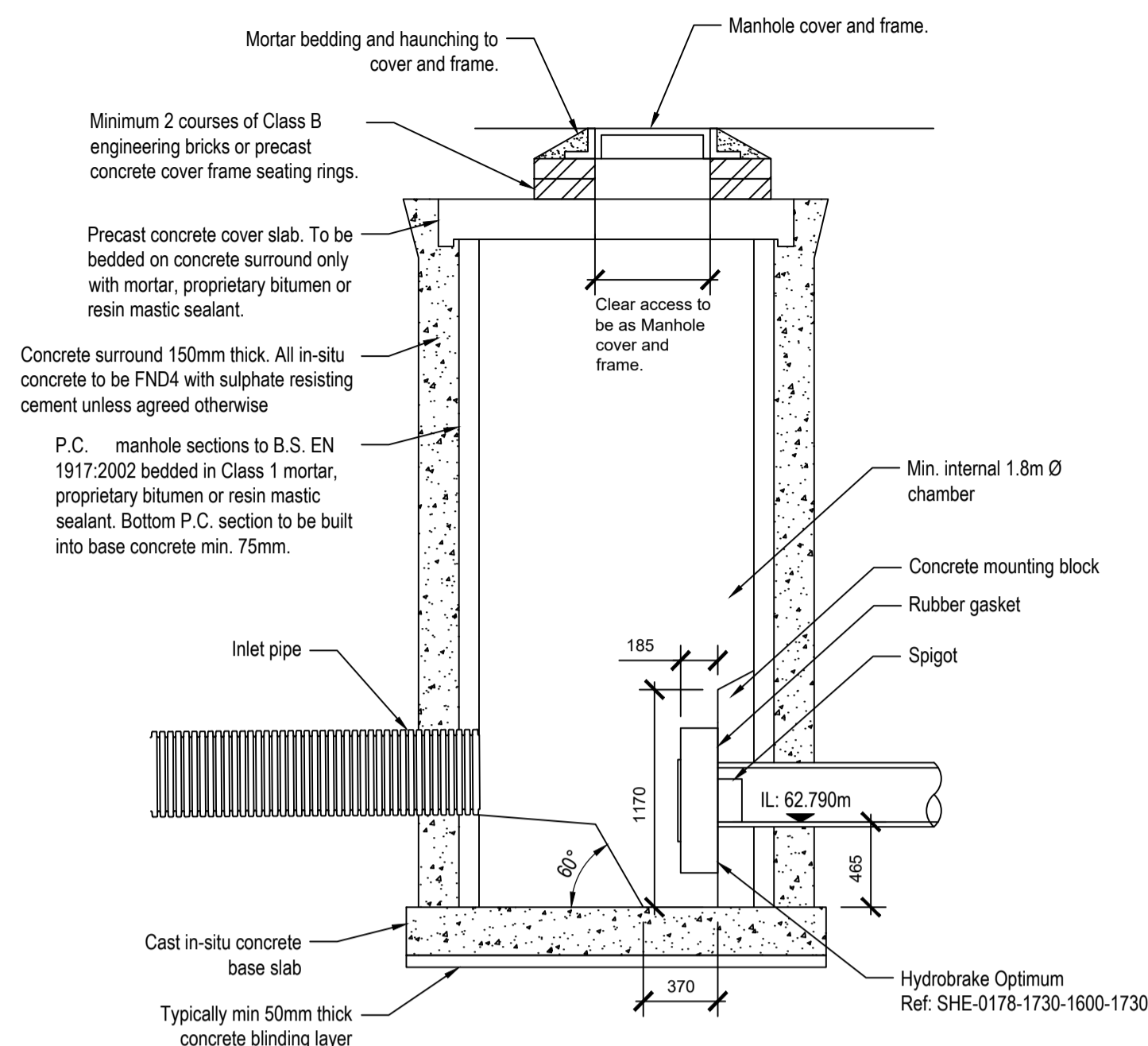

Hydrobrake Flow Control Manhole Detail MH S12
 Scale 1:25

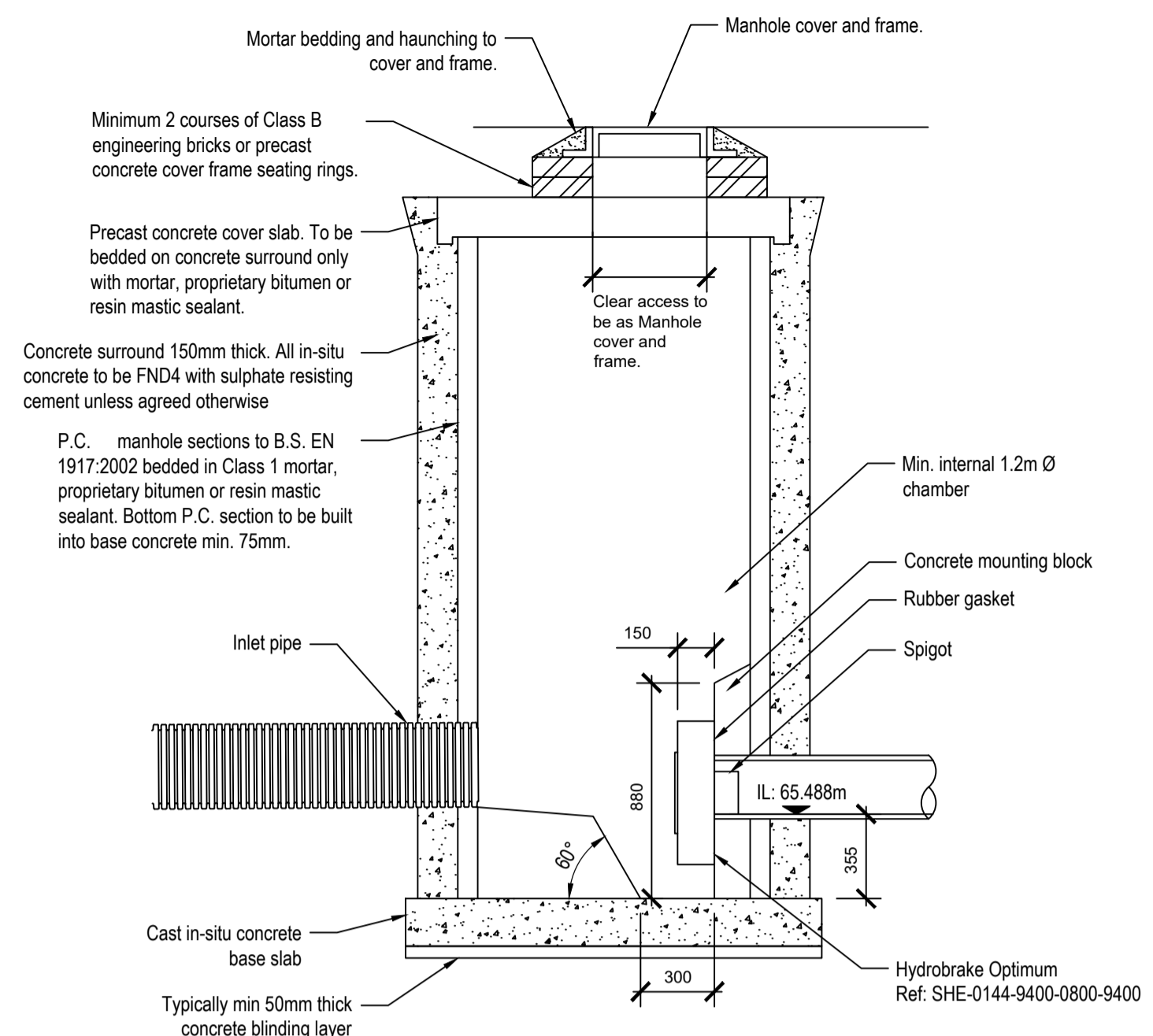

Hydrobrake Flow Control Manhole Detail MH S15
 Scale 1:25

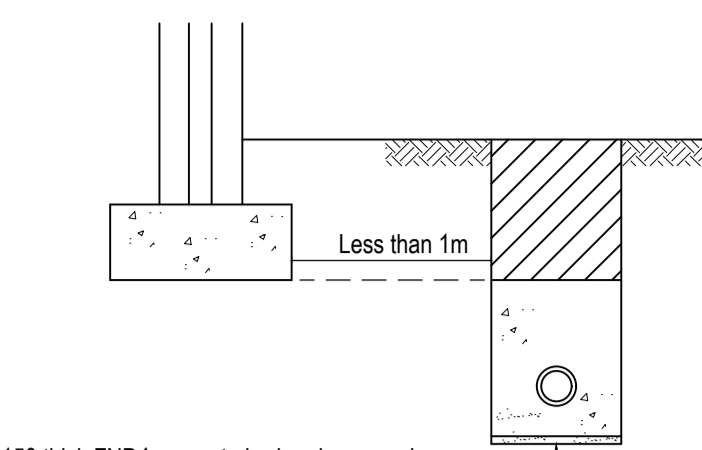

150 thick FND4 concrete bed and surround required when drain trench edge is less than 1m from foundation. Concrete to be brought up to underside level of footing concrete.
 Note: Concrete bed and surround to be discontinued at every pipe joint using compressible filler to be 18mm thick for pipework upto 450mm diameter

Drain trench edge less than 1m from footing/foundation edge

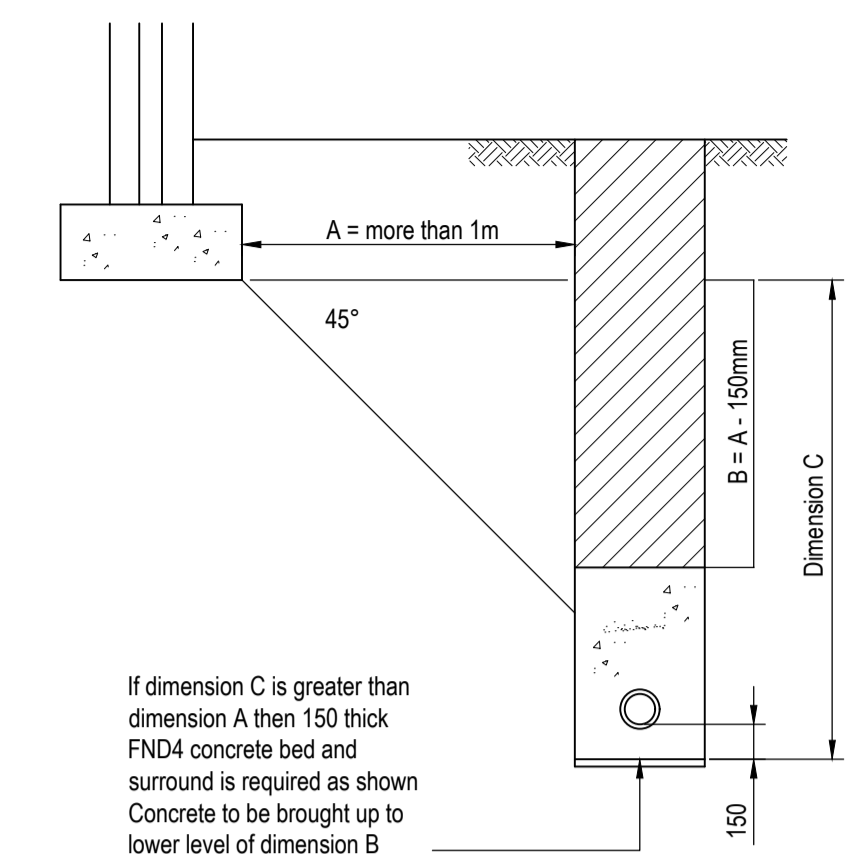

If dimension A then 150 thick FND4 concrete bed and surround is required as shown. Concrete to be brought up to lower level of dimension B.

Drain trench edge more than 1m from footing/foundation edge

Pipe Bedding Adjacent to Foundation
 (Scale 1:25)

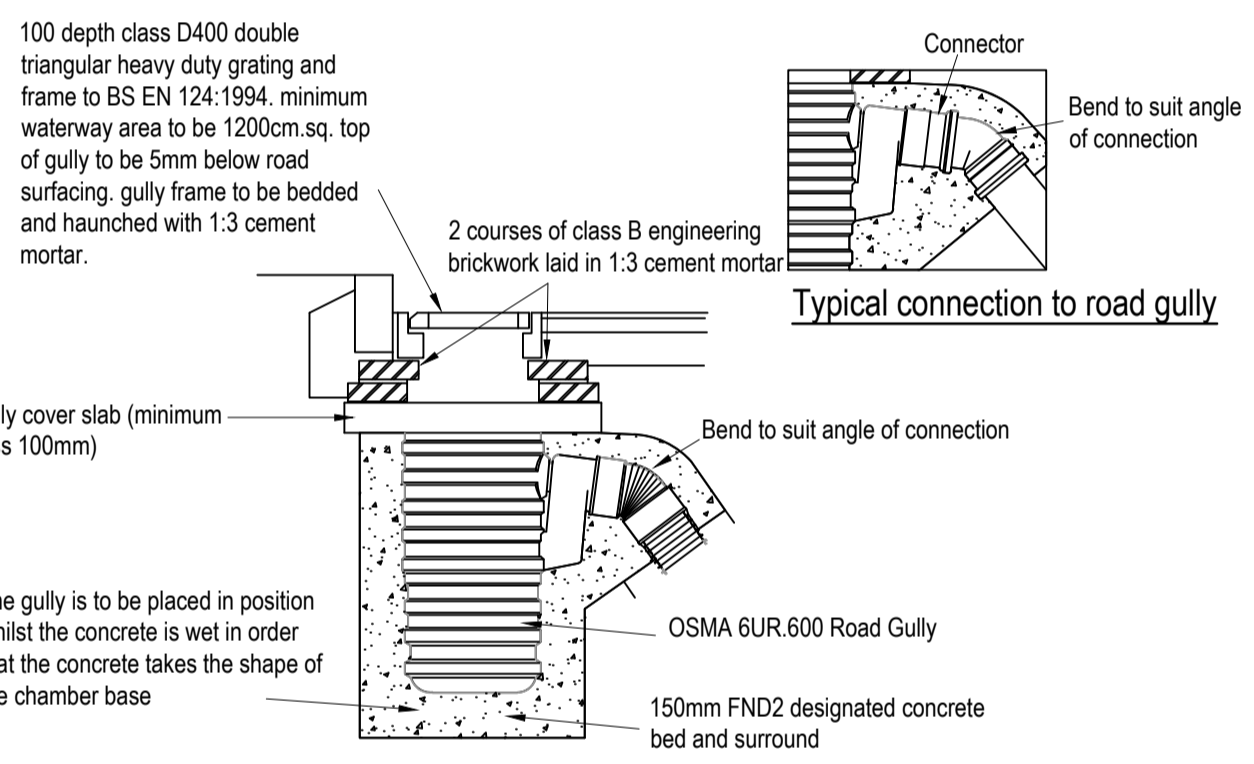

Typical Private Road Gully
 (Scale 1:25)

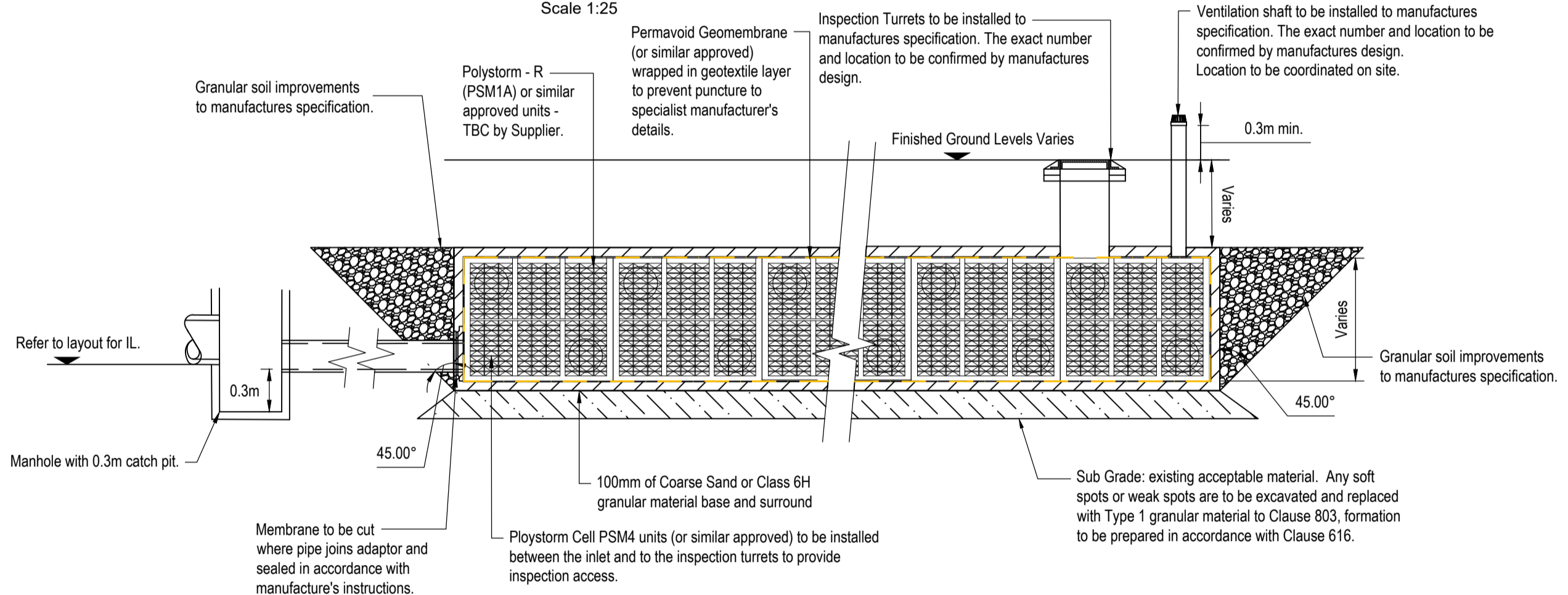

Typical Tanked Geo Cellular Crate Detail
 Not to Scale

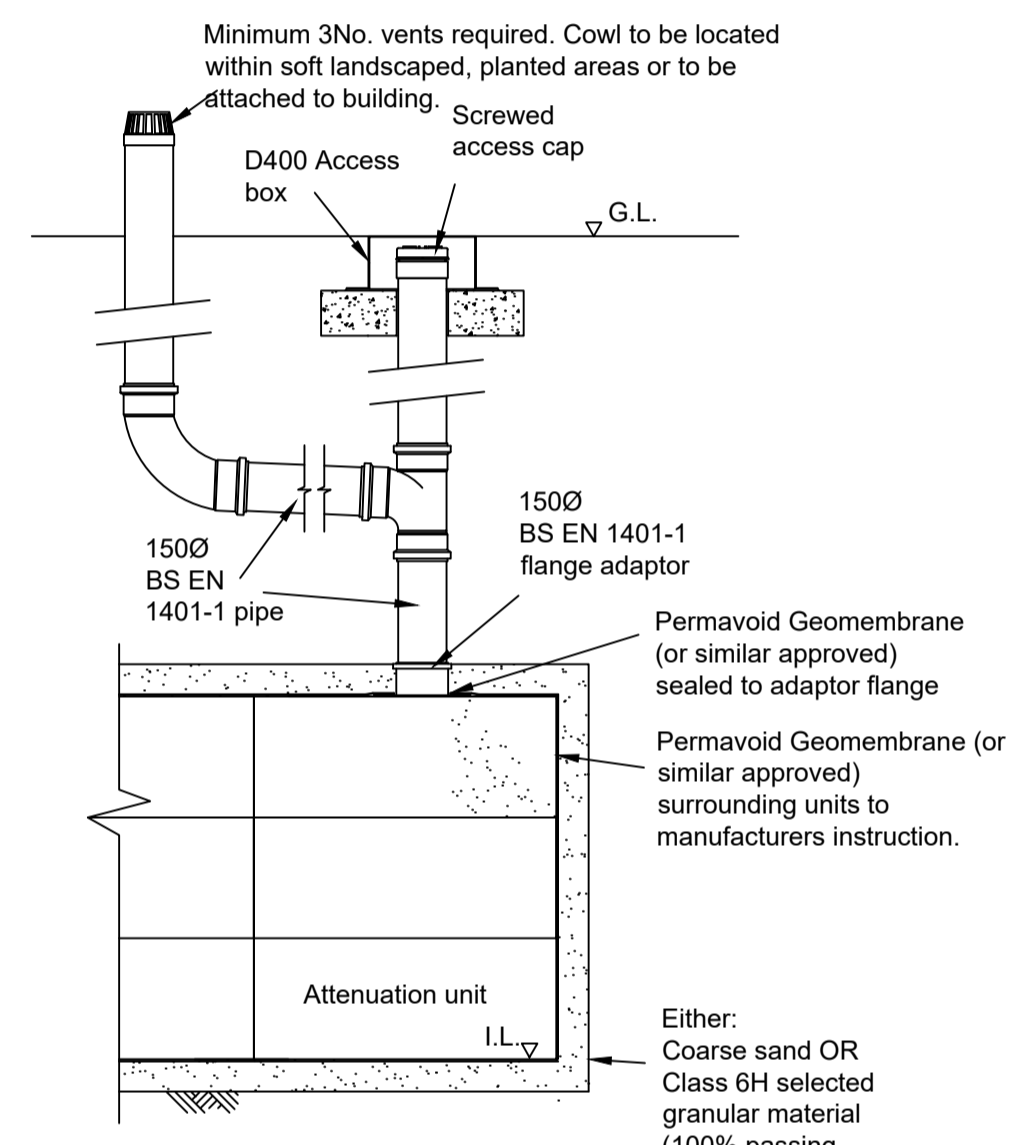

Typical Tank Vertical Vent Pipe Connection
 Scale 1:25

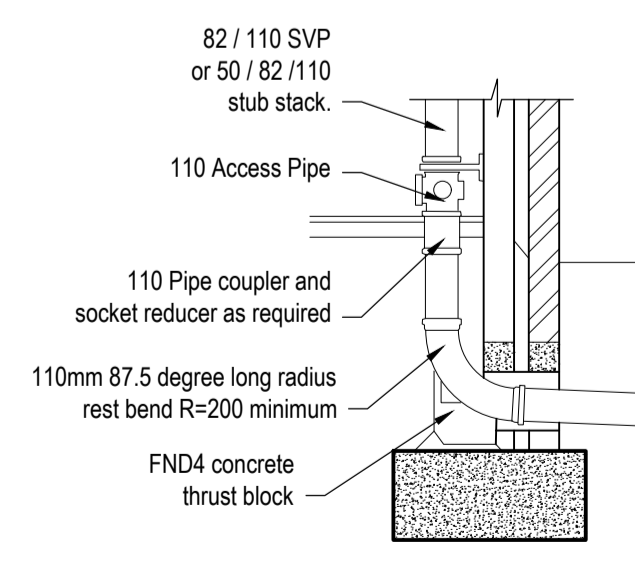

Soil vent pipe and sub stack connection

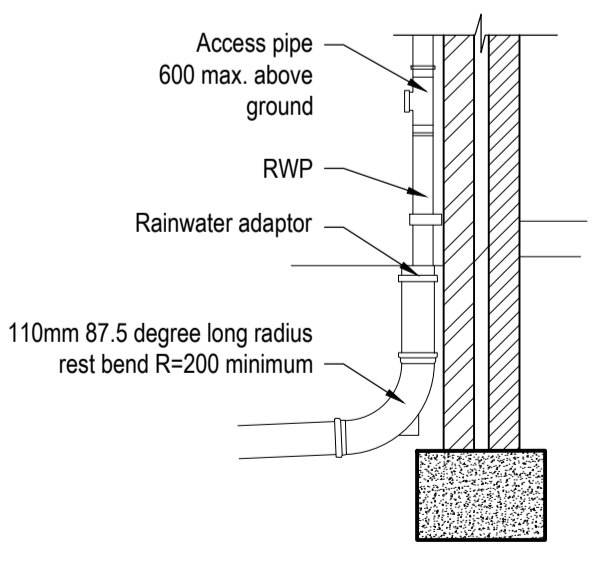

External RWP to Drain

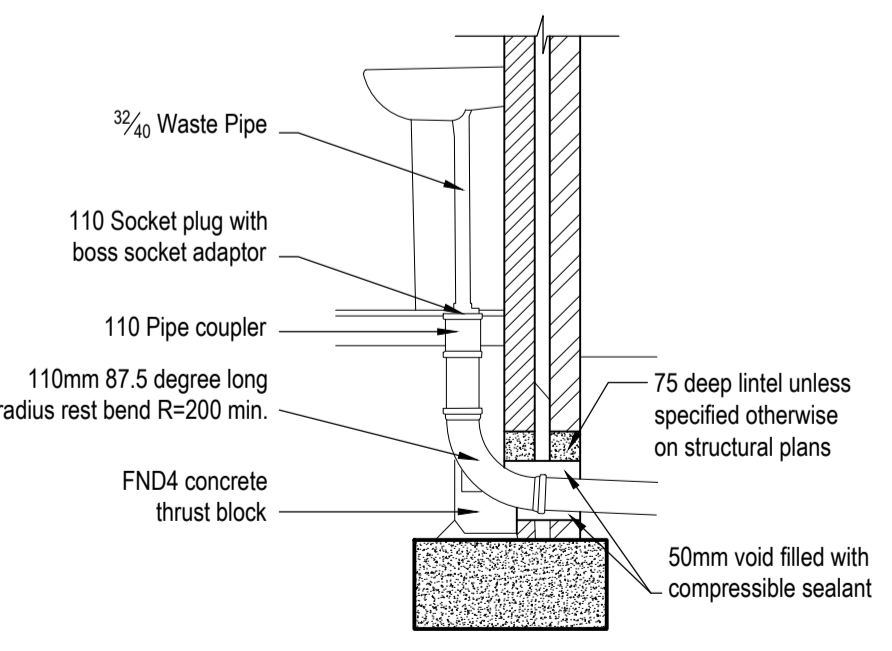

Internal Waste Pipe Connection

Internal to External Drainage Connections
 (Scale 1:25)

Rev.	Date	Description	Drn / Chk / Appr.
P01	28/11/2025	Draft Issue	LC / CS
Submittal: S3 - Suitable for Review & Comment			

JNP GROUP
 CONSULTING ENGINEERS
 Amersham • Belfast • Brighouse • Bristol
 Hartlepool • Sheffield • Warwick
 www.jnpgroup.co.uk

Client: John L Brierley Ltd.
 Job: Turnbridge Mills, Quay Street, Huddersfield
 Title: Drainage Details Sheet 2 of 2

Classification: FI_60_20
 Scale @ A1: As Shown
 Accredited Contractor: HAS, Constructionline, Supplier to British

Project - Originator - Volume/System - Level/Location - Type - Discipline - Number: S12097 - JNP - XX-XX-DR - C - 3002
 Revision: P01

APPENDIX B: RECORDS OF MAINTENANCE

APPENDIX C: SPEL OIL SEPARATOR MAINTENANCE REQUIREMENTS

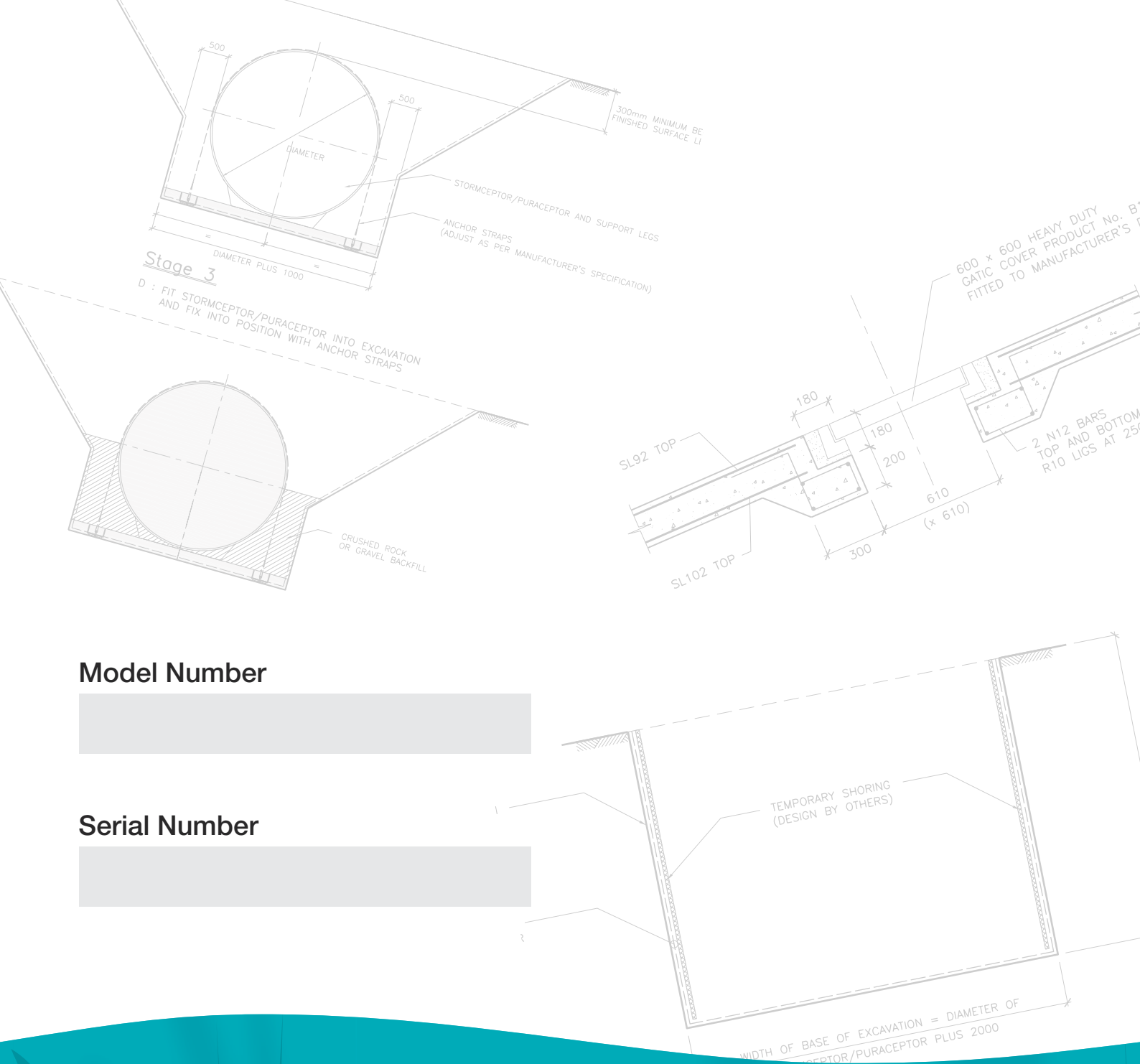

Model Number

Serial Number

SPEL PURACEPTOR™ CLASS 1

Operation and Maintenance Manual

www.spel.com.au

Introduction

Congratulations on your purchase of a SPEL Environmental Stormwater Quality Improvements Device.

With proper care and by following a few simple guide lines your system will give you many years of dependable service.

Important

Only qualified personnel should maintain, operate and repair you Stormwater system. Any wiring of equipment should be performed by a qualified electrician.

Warning

Operation may cause injury. Take all necessary precautions, wear protective equipment, refer to Engineers Department.

For your own safety, read all instruction manuals prior to working on equipment.

Safety Precautions

- Follow all “occupation, health and safety” regulations.
- Ensure maintenance personnel are aware of “Confined Spaces” guidelines, which must be followed.
- Make sure that there is sufficient oxygen and that there are no poisonous gases present.
- Check the explosion risk before welding or using electric hand tools.
- Do not ignore health hazards. Observe strict cleanliness.
- Ensure that the lifting equipment (where required) is in good condition.
- All personnel who are to work with these systems should be vaccinated against diseases that can occur.
- Keep a first aid kit handy.

Health & Safety

Maintenance should be carried out by a competent contractor in accordance with the above procedures.

Health and Safety at Work legislation and good building practice.

A warning notice should be visible at the top of each access shaft – ‘danger, harmful fumes’ and ‘respirators should be worn in this tank.’ Before entering persons must be qualified in accordance with ‘confined space’ requirements.



Information contained in this data sheet is approximate and for general guidance only. In accordance with the companies policy of constant improvement and development SPEL Products reserves the right to change the specification without prior notice.

SPEL PURACEPTOR™ CLASS 1 Operation & Maintenance Manual



- » Service Stations
- » Fuel Depots
- » Windfarms
- » Switchyards
- » Sub Stations
- » Power Stations
- » Industrial Locations

Contents

SPEL Puraceptor – How it works.....	4
SPEL Puraceptor Maintenance.....	5
SPEL Coalescer Units.....	6
SPEL Auto Closure Device	7
SPEL Oil Alert System	8
Spare Parts List	10

OIL CONTAINMENT

"How it works"

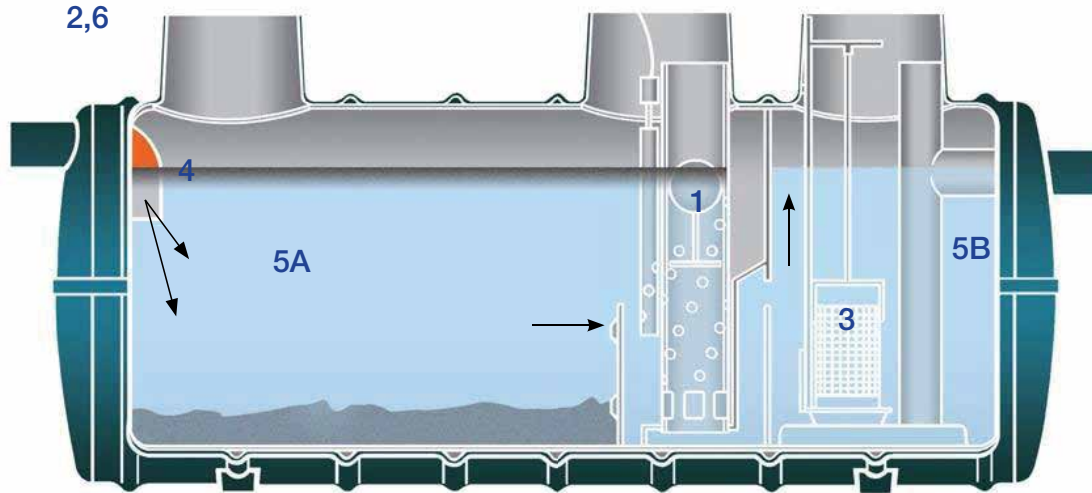

SPEL Puraceptor™ is a FULL RETENTION separator that treats all flows and is sized to contain more than the anticipated maximum oil spillage enabling it to be fully operational at all times.

It has two chambers, a coalescer and is fitted with an automatic closure device specifically designed to treat and contain major oil spills thereby making it suitable for high risk applications.

It achieves a water discharge quality of 5mg light liquids per litre complying to European Standard BS EN 858.1. 2006.

Treatable flow rates range from 2LPS to 200LPS.
Pipe sizes range from 100mm to 450mm (larger sizes on request).

Careful and proper planning by corporate Australia and government bodies is essential when designing and implementing systems that are effective in protecting our environment. The proven and independently accredited SPEL Puraceptor™ (complies to European Standard BS EN 1858.1 2006) is an Australian made stormwater treatment and oil containment device that can contain and prevent light liquid pollutants from discharging into our waterways.

1 AUTOMATIC CLOSURE DEVICE

The AUTOMATIC CLOSURE DEVICE (A.C.D.) is a precisely engineered device comprising a water-bouyant ball that is sensitive to any change in the water density as a consequence of light liquids build up, thereby automatically activating a process of depressing the A.C.D. to SHUT OFF the separator, preventing pollutants from discharging to drains and waterways.

2 FULL RETENTION

All liquid is treated. There is no by-pass operation.

3 COALESCER EQUIPPED

Provides a coalescing process for the separation of smaller globular of light liquid pollutants to reduce the light liquid content in the outlet to 5mg/litre or less.

4 INLET DIP PIPE - FLAME TRAP

For minimum turbulence and to prevent fire and inflammable vapours passing through to the drainage system.

5 TWO CHAMBER

A non-turbulant flow through two horizontal treatment chambers, utilising the underflow principle to retain light liquids in all flow conditions.

A. CONTAINMENT CHAMBER: Where Total Suspended Solids (TSS) silt, sediments, sludge and gross pollutants are trapped and settle on the chamber floor and where light liquids are contained.

B. COALESCER CHAMBER: Where light liquids separation is enhanced reducing it to 5mg/litre or less prior to discharge.

6 GRAVITY OPERATED

Will function in the event of power failure and fits into existing pipe drainage systems or new sites.

7 MAINTENANCE

Easy and safe with no entering of the tank required.

Puraceptor Maintenance

Puraceptors™ should be inspected at three - six - or twelve monthly intervals depending on site conditions, to determine the depth of retained pollutants and silt in both chambers and the correct operating of the ACD (automatic closure device). When the depth of the oil/fuel retained has reached the predetermined design level, (approx. 50mm) or after a spill it should be cleaned out.

1. CONTAINMENT CHAMBER:

Where silt, sediments, sludge, gross pollutants settle out and light liquids are retained. The auto closure device operates in its retaining tube next to the oil alert sensor probe.

2. COALESCER CHAMBER:

Where light liquids separation is enhanced prior to discharge and where the coalescer unit is incorporated, the coalescer should be removed and cleaned in accordance with the requirements set out in the coalescer data sheet.

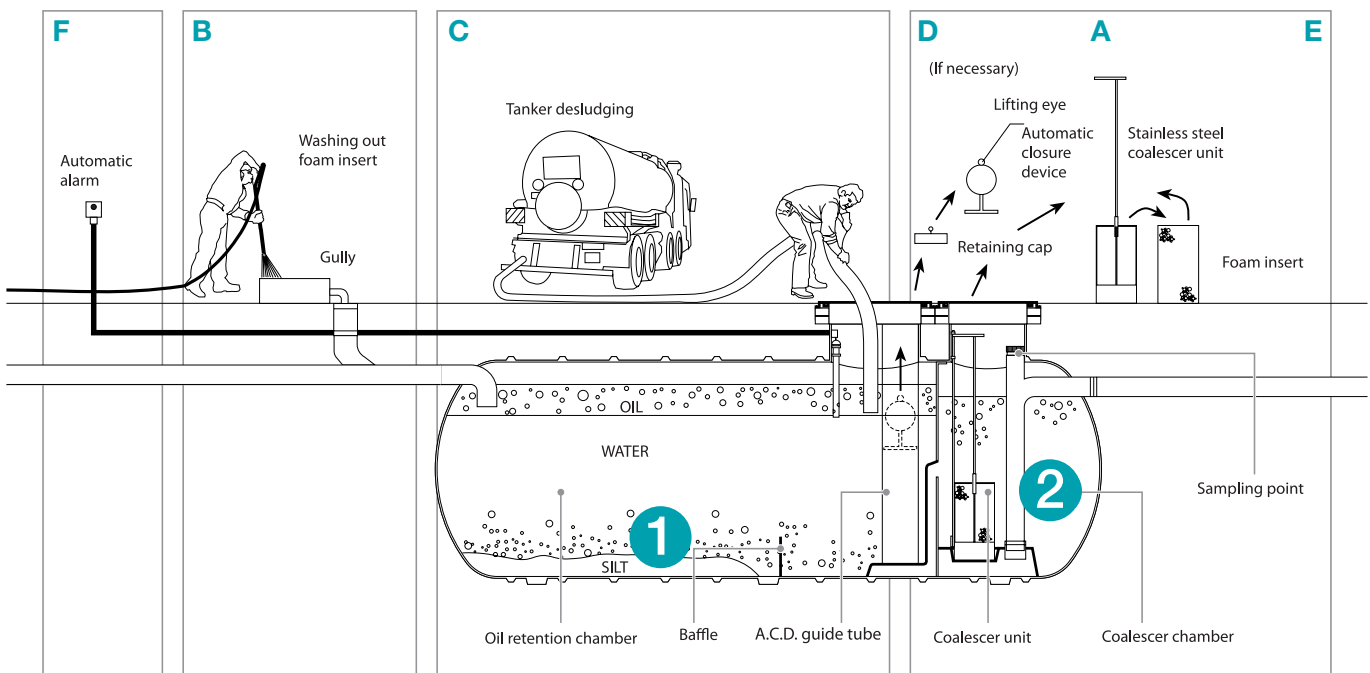

MAINTENANCE PROCEDURE

A Coalescer unit

Use the lifting handle or the chain and lift the coalescer unit out of the tank and place it near the Puraceptor™. In a retained area so pollutants do not escape.

B Cleaning foam insert

Remove foam insert and wash with normal water pressure ensuring the dirty water runs into the Puraceptor™.

C Sucking out oil/fuel & silt

Suck off the retained oil from both chambers of the Puraceptor™ and then the silt deposited on the bottom, leaving sufficient water to ensure the (auto closure device) ACD remains floating.

D Sucking out complete contents (if necessary)

If the quantity of pollutants exceeds recommended level, the complete contents of the Puraceptor™ may need to be removed. After sucking out completely, remove the ACD.

After sucking out completely, remove the ACD. Using a pole with a hook, lift out the ACD using the lifting eye on the float, if fitted.

E Re-insert coalescer unit and ACD

Re-insert the foam insert into the stainless steel coalescer unit and re-insert the coalescer unit into the Puraceptor™ as provided with the SPEL lifting/location/locking system.

Partially fill the Puraceptor™ with clean water (if necessary) to ensure the ACD when re-inserted remains floating. Re-insert the ACD.

Finally check the ACD is floating after it has been replaced to safeguard against its removal by unauthorised persons, unless depth of tank precludes doing so from ground level.

F SPEL automatic alarm/monitoring system

The SPEL automatic alarm/monitoring system probe should be lifted out of the probe protection tube, wiped clean and re-inserted. the system should now be reset according to instructions.

SPEL Coalescer Units

Prior to installation

1. Remove any strapping / ropes which have been used to hold the coalescer units from shifting in transit.
2. The access shaft(s) above the coalescer units should be covered to prevent ingress of concrete, dust, debris etc., which could clog the foam inserts.
3. On completion of installation, check that the coalescer unit is inserted securely into the base socket.

On heavily polluted sites silt and contaminants may build up in the coalescer unit foam inserts and add significantly to its weight. Use lifting chain sets that are on hooks at ground level for safe lifting with a tripod or hoist.

Installation

During installation, it is important that the foam inserts are not clogged with dust, debris or drops of wet concrete. To safeguard against this, we recommend covering the access shaft with a sheet of polythene, if not already covered.

Commissioning

On completion of installation, check the foam insert is fitted inside the stainless steel coalescer unit and the coalescer unit is inserted securely into the base socket.

Maintenance

1. Lift handle and coalescer unit out of the tank and place in a retained area so pollutants do not escape.
2. Remove foam insert and wash with normal water pressure ensuring the dirty water runs into the Puraceptor™ / Stormceptor™.
3. Make sure the hole in the centre of the coalescer foam is facing towards the manhole when installed in the tank.
4. Re-insert the foam insert into the stainless steel coalescer unit and re-insert the coalescer into the Puraceptor™ / Stormceptor™. After the tank has been cleaned.

The SPEL Puraceptor™ Class 1 separator and the SPEL Stormceptor™ Class 1 by-pass separators incorporate coalescer units. The coalescer units provide a coalescence process for the separation of small globules of light liquid pollutants before final discharge to the surface water drain.

Coalescers are found in the second chamber of the SPEL Puraceptor™ and the second chamber of the SPEL Stormceptor™ Class 1.

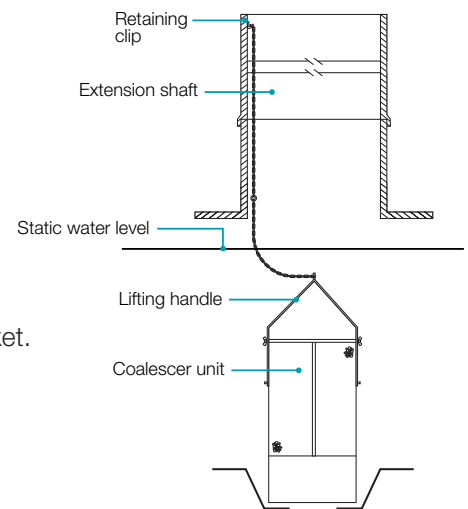

Figure 1. Coalescer unit with lifting chains.

SPEL coalescer units guide rail system/lifting, locating and locking system

SPEL coalescer unit guide rail system

This facilitates easy insertion and removal of coalescer units. The system is robust, manufactured throughout in stainless steel and is action positive, leaving no doubt the coalescer unit is located properly.

Brackets fixed to the top and bottom of the coalescer unit simply engage the stainless steel guide rail fixed to the top of the stub access shaft. The coalescer is then lowered in the normal way, being guided at the correct angle into the conical base unit which finally locates the coalescer unit into its final position.

Extension guide rails can be incorporated into the SPEL extension shafts to suit (preferably when ordered with the separator).

However, when the separator is full of water, debris or sludge accumulated over a period could prevent the coalescer unit from re-seating correctly after servicing.

The coalescer unit lifting / locating / locking system ensures the coalescer unit is seated correctly and can be locked into position to prevent tampering.

The stainless steel lifting handle can be extended to suit deep tank inverters and provide easy access for lifting manually or with a tripod and hoist utilising the lifting hook.

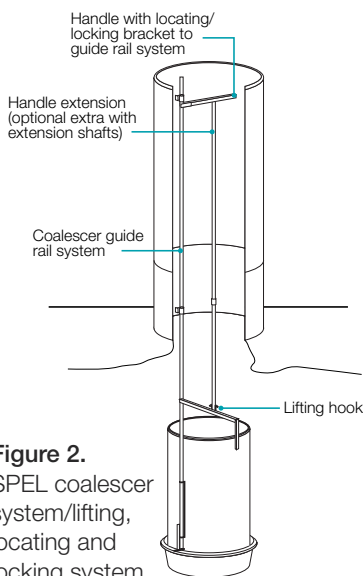

Figure 2. SPEL coalescer system/lifting, locating and locking system.

SPEL Automatic Closure Device (ACD)

SPEL ACD

The Automatic Closure Device (ACD) is found in the first chamber of a Puraceptor™. The purpose of the ACD is to close the separator off automatically when the maximum storage capacity of light liquid is attained.

The ACD is to ensure that in the event of a major spillage, pollutants do not pass into the drainage system; it should not be regarded as a substitute for an automatic alarm / monitoring system.

Prior to installation

Prior to installation the ACD retaining tube should be covered to prevent ingress of concrete etc., which could fall onto the ACD and upset its calibration.

Operation and Maintenance

If the tank should fill with light liquid, the ACD which is calibrated for a specific gravity of 0.85, will automatically sink and close off the SPEL Puraceptor™.

Normally routine maintenance would include removing light liquid intercepted within the Puraceptor™. If a SPEL automatic alarm / monitoring system is incorporated, it will automatically indicate when the Puraceptor™ should be emptied. Only in an emergency will the Puraceptor™ fill to its maximum and operate the ACD.

In such an event the Puraceptor™ should be completely sucked out and the ACD lifted out. Check that the ACD is in good working condition – ie. Lifting hook secure and sealed; float not leaking; knuckle joint free and clean; sealing ring intact and complete. Clean with warm soapy water before re-inserting.

To re-insert the ACD, partially fill the Puraceptor™ with clean water (if necessary) to ensure the ACD when re-inserted remains floating.

Re-insert the ACD.

Finally check the ACD is floating after it has been replaced to safeguard against its removal by unauthorised persons, unless depth of tank precludes doing so from ground level.

SPEL Puraceptor™ Class 1 separators – Two Chamber Models Commissioning

After the tank has been installed, leave the water in.

1. Remove the ACD from the packing box, taking care not to cause damage.
2. Insert the ACD into the retaining tube using the lifting eye, if fitted, ensuring it floats correctly with the float (top section approx. 50mm) just visible above the water level.

Note: If the tank's invert depth exceeds 1metre, it is advisable to remove the retaining cap prior to installation and only replace after inserting the ACD, if it is possible to do so from ground level.

Automatic closure device SPEL Puraceptor™ Class 1 separators (two chamber)

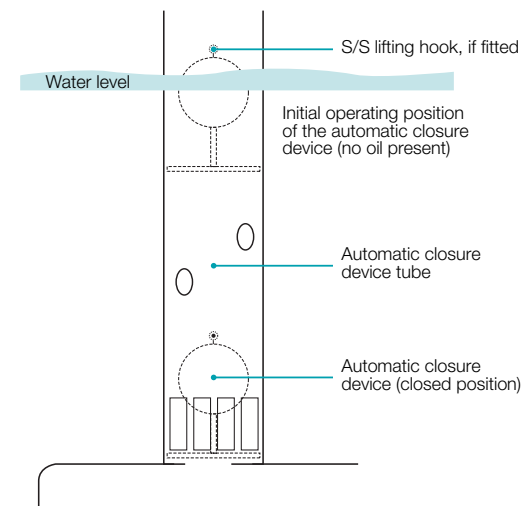

SPEL Automatic Alarm/ Monitoring System

The SPEL automatic alarm/monitoring system provides a audible warning alarm when the level of the oil in the SPEL separator reaches approximately 10% of the storage volume under static liquid level conditions. This is a early warning system that is used for spills or lack of maintenance.

The system comprises of a probe mounted in the main separation chamber which senses when the designed volume of light liquids has accumulated and sends a signal to the electronic control unit activating a red 'empty now' warning light and an audible alarm.

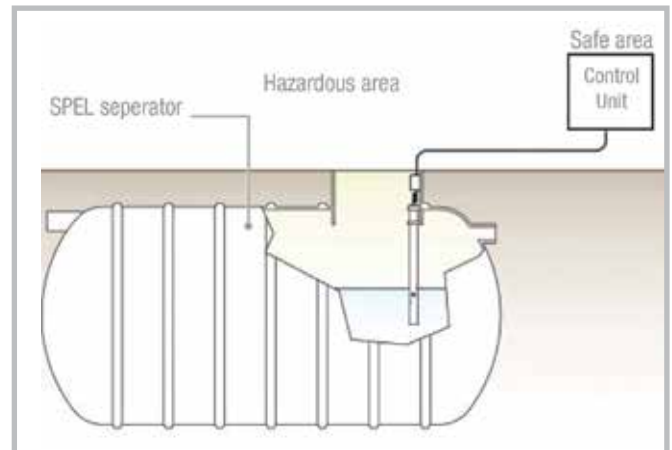

Operation

The probe is freely suspended in the probe protection tube in the separator at the correct level. When the oil-layer or depth of hydrocarbons reaches the predetermined level, the top of the probe will be immersed in the oil, breaking the circuit and activating the alarm. It is a 'fail-safe' system providing complete assurance that it is operative. If a fault occurs it will be signalled immediately.

Installation

Control unit (general positioning)

The control unit has been designed to be located indoors and outdoors, within a nonhazardous area. It should be wall mounted and positioned such that the LED display and push switches on the front panel can be readily seen and accessed. The unit can be secured to the wall by using the four mounting holes provided. Included within the control is an intrinsically safe circuit (approved according to ATEX Directive 94/9/EC), to which the probe unit is connected.

Maintenance

When the separator is maintained, lift the probe out of the probe protection tube, check it operates the alarm (see under Tests Ref. 10.2) and at the same time wipe oil and contaminants from the probe to prevent a fake alarm after re-inserting.

Insert probe onsite

The probe protection tube is factory fitted and the probe matched to ensure the alarm is activated when the light liquids reach approximately 10% of the storage volume the SPEL separator is designed for.

All that is required on site is to undertake the electrical installation in accordance with the instructions provided and lower the probe with the pre-fixed location cap into the probe protection tube. When the cap locates onto the top of the probe protection tube, the probe is suspended at the correct level.

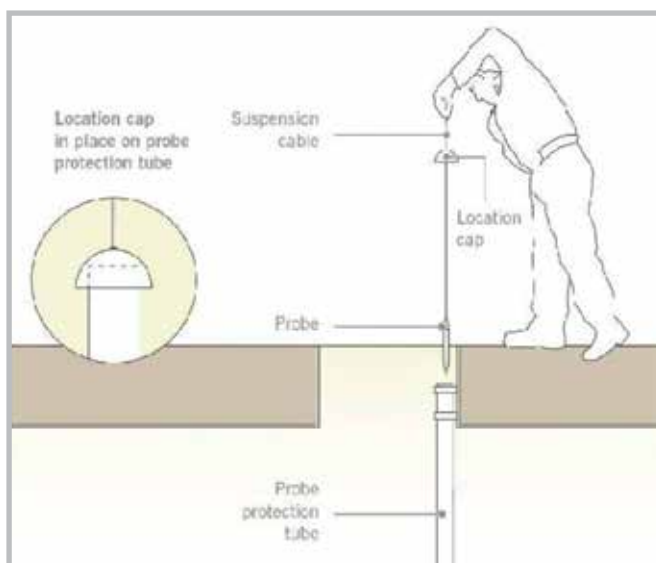
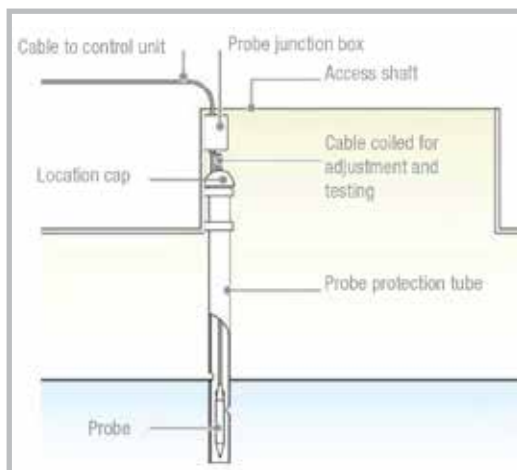

SPEL Automatic Alarm/ Monitoring System

Continued...

Control unit (electrical connections)

1. Mains voltage connection;

The control unit should be connected to a suitable 220/240V AC supply and fused at 3 amps.

Note: This appliance must be earthed.

2. Control unit/probe junction box connection

Wiring from the control unit to the probe junction box in the separator chamber requires a 3-core screened, 0.75mm core section cable.

Maximum cable length: 300 metres.

3. Probe connection

A 5 metre 3-core probe cable is normally fitted to the junction box and the probe.

After all connections have been made, the cables must be secured by tightening each entry gland.

Probe

The probe is installed freely suspended in the SPEL separator within the probe protection tube. The 3-core cable is connected into the junction box mounted in the access shaft above the probe protection tube. Extra cable is provided to enable raising the junction box where extension shafts are incorporated.

Important note: In all cases good, standard electrical practice should be followed and the installation must conform to the Australian Wiring Rules – AS 3000 – 2007.

In essence, the installation must be such that the intrinsic safety is not compromised by:

- Exposure to risk of mechanical damage
- Unauthorised modification of interference
- Exposure to moisture, dust and foreign bodies
- Excessive heat
- Invasion of intrinsically safe circuit by other electrical equipment or circuitry

Certificate of conformity

The alarm device has been approved to be used in explosion-hazardous areas. The control unit and probe are approved according to ATEX Directive 94/9/EC. These approvals mean that the probes can be installed in Zone 0, which is continuously explosion-hazardous.

The SPEL oilset control unit must be located in the safe area, but it can be connected to the probe without any barrier.

Tests (10.2)

The function can be tested by lifting the probe within the probe protection tube. In approximately 5 seconds, the alarm is given by a red light and audible signal. Both relays release. Push the RESET button – the buzzer goes off and relay pulls in.

When the probe is placed in water again, relay pulls in and the red light goes off.

Cable break and short circuit test

Also the function can be tested in case of cable fault or short circuit. First cause short circuit in probe cable terminals 1 and 2. Then the yellow light of short circuit is lit. Both the relays pick up and the buzzer goes on. Remove the short circuit and reset the buzzer.

Simulated Function Test

The function of probe, cable and electronics can be tested. Push the TEST button for 2 to 5 seconds. Both relays pick up, and the red light is lit. When the TEST button is released, the red light goes off and relay returns to its normal position. The buzzer and relay must be reset.

Installation

Important note: It is important that installation is carried out by a competent technician familiar with this type of equipment or contact our Special Products Division for installation, commissioning and maintenance service.

Spare Parts List

DATE: _____

INVOICE NO: _____

TYPE: _____

MODEL: _____

SERIAL NO: _____

JOB NO: _____

Line	Description	Qty	Part No.
1			
2			
3			
4			
5			
6			
7			
8			

For all spare parts enquiries, please phone: + 61 2 8838 1055.

Fax form to +61 2 8014 8699

MAINTENANCE SERVICE LEDGER

Model No.	
Installation Address	
Initial Operating Date	
Working Capacity	
Primary Chamber Spill Capacity	
Oil Alert Probe trigger threshold	
Minimum Maintenance Frequencies	ANNUALLY from the initial operational date or if indicated by the oil alert probe alarm
<p>Note: Oil Alert Probe alarm is triggered when fuel/oil hydrocarbons reaches 10% of primary chamber capacity.</p>	

MAINTENANCE RECORD

Service Date	Coalescer Flushed	Primary Chamber Sediment Removed & Hydrocarbons Skimmed	Secondary Chamber Sediment Removed & Hydrocarbons Skimmed	Oil alert Probe Cleaned & Alarm Checked	Service Manager Name & signature

HEAD OFFICE

PO Box 2011
North Parramatta NSW 1750
104 Grose St
Parramatta NSW 2150

Phone: + 61 2 8838 1055

Fax: +61 2 8014 8699

STATE CONTACTS

New South Wales	61 2 8838 1055
Canberra	61 2 6128 1000
Queensland	61 7 3277 5110
Victoria & Tasmania	61 3 5274 1336
South Australia	61 8 8275 8000
West Australia	61 8 9350 1000
Northern Territory	61 2 8838 1055
New Zealand	64 9 276 9045

www.spel.com.au

SPEL Environmental accepts no responsibility for any loss or damage resulting from any person acting on this information. The details and dimensions contained in this document may change, please check with SPEL Environmental for confirmation of current specifications.

APPENDIX D: POLYSTORM TANK CDM REGULATIONS RISK ASSESSMENT AND METHOD STATEMENT FOR THE INSPECTION AND MAINTENANCE

Health, Safety and Access Requirements for Inspection and Maintenance

All inspection and maintenance activities associated with the attenuation storage tank shall be undertaken in accordance with relevant health and safety legislation, including but not limited to the Construction (Design and Management) Regulations 2015 and the Confined Spaces Regulations 1997.

Access to the attenuation tank will typically be via manholes or access chambers as per the construction details provided, which shall be considered confined spaces. As such, all works shall be undertaken by competent and trained personnel and in accordance with an approved Risk Assessment and Method Statement (RAMS) and Permit to Work system where required.

The following requirements shall be adhered to:

General Requirements

- Maintenance operations shall be planned and carried out to minimise risk to operatives and others.
- Wherever practicable, inspection of the attenuation tank shall be undertaken remotely (e.g. CCTV survey) to avoid the need for confined space entry.
- Safe access and egress points shall be maintained at all times.
- Working areas around open chambers shall be suitably cordoned off with barriers and warning signage.

Confined Space Working

- Entry into the attenuation tank shall only be undertaken where absolutely necessary.
- A confined space permit shall be implemented prior to entry.
- Atmospheric testing shall be carried out before and during entry to monitor oxygen levels and the presence of harmful gases.
- Continuous gas monitoring equipment shall be used.
- Suitable ventilation shall be provided where required.
- A trained top person shall be present at all times during entry operations.
- Emergency rescue equipment (e.g. tripod and winch) shall be available and operable.

Operational Hazards

Key risks associated with inspection and maintenance activities include:

- Hazardous atmospheres (toxic or oxygen-deficient)
- Sudden ingress of water during rainfall events
- Slips, trips and falls around access chambers
- Manual handling of covers and equipment
- Exposure to contaminated water and sediments
- Risks associated with high-pressure jetting equipment

- Appropriate control measures shall be implemented to mitigate these risks, including the use of suitable personal protective equipment (PPE), safe systems of work, and trained operatives.

Weather and Flood Risk

- Maintenance activities shall not be undertaken during periods of heavy rainfall or where there is a risk of rapid inflow to the system.
- Weather forecasts shall be reviewed prior to undertaking any works involving access to the tank.

Waste Handling and Environmental Protection

- Any sediments, debris or contaminated materials removed during maintenance shall be handled and disposed of in accordance with relevant environmental legislation.
- Waste shall be removed by a licensed contractor and taken to an appropriately permitted facility.

Emergency Procedures

- An emergency plan shall be in place prior to commencement of works.
- In the event of an unsafe condition, works shall cease immediately and operatives shall evacuate the confined space.
- Rescue shall only be attempted by trained personnel using appropriate equipment.
- Emergency services shall be contacted where required.

Method Statement

1. Preparation

- Review drawings, O&M manuals, and previous inspection records
- Undertake briefing/toolbox talk
- Establish exclusion zones and safe access
- Obtain required permits (Confined Space, Permit to Work)

2. Access & Initial Checks

- Carefully remove chamber covers using correct lifting equipment
- Install edge protection/barriers
- Undertake atmospheric gas testing at access point

3. Inspection

- Carry out CCTV inspection as primary method
- Identify:
 - Sediment accumulation
 - Blockages
 - Structural condition of chambers/pipes

4. Cleaning & Maintenance

- Remove silt using vacuum tanker
- Jet pipework to clear blockages (controlled pressure)
- Avoid damage to geocellular tank structure
- Collect all waste for licensed disposal

5. Confined Space Entry (Only if unavoidable)

- Implement full confined space controls:
- Permit issued
- Competent trained operatives only
- Harness, tripod, and rescue system in place
- Top man in attendance at all times
- Continuous gas monitoring and communication maintained

6. Completion

- Final inspection carried out
- Replace and secure all covers
- Remove barriers and reinstate area
- Record findings and maintenance actions

7. Emergency Arrangements

- Stop work immediately if unsafe conditions arise
- Evacuate confined space without delay
- Do not attempt rescue without trained team and equipment
- Contact emergency services (999) if required
- First aid administered by trained personnel

8. Residual Risks

- Confined space hazards remain controlled but present
- Sudden inflow during extreme weather
- Equipment malfunction

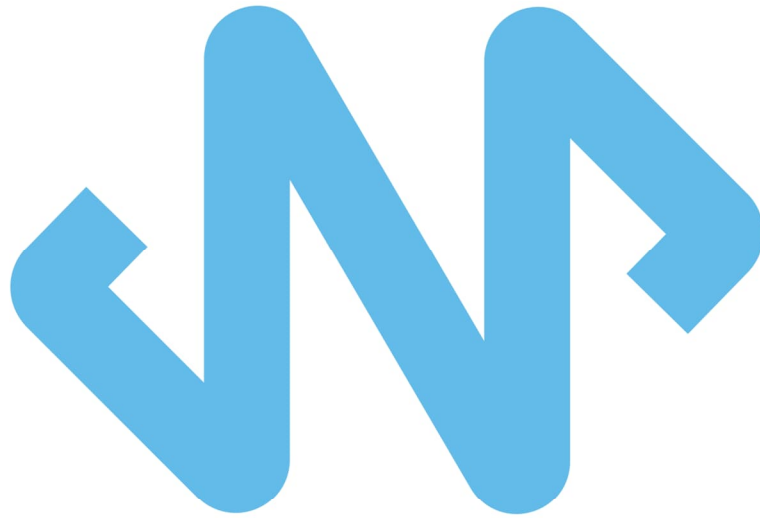

JNP GROUP

CONSULTING ENGINEERS

Amersham

Sycamore House
1 Woodside Road
Amersham
Buckinghamshire
HP6 6AA

telephone

01494 771221

more info

www.jnpgroup.co.uk/contact

Hartlepool

The Innovation Centre
Venture Court (Hub2)
Queens Meadow Business Park
Hartlepool
TS25 5TG

telephone

01429 800711

more info

www.jnpgroup.co.uk/contact

Belfast

Arthur House
41 Arthur Street
Belfast

BT1 4GB

telephone

02890 027270

more info

www.jnpgroup.co.uk/contact

Sheffield

MBP2 Meadowhall Business Park
Carbrook Hall Road
Sheffield
South Yorkshire
S9 2EQ

telephone

0114 244 3500

more info

www.jnpgroup.co.uk/contact

Brighouse

Woodvale House
Woodvale Road
Brighouse
West Yorkshire

HD6 4AB

telephone

01484 400691

more info

www.jnpgroup.co.uk/contact

Warwick

Portobello House
Portobello Way
Warwick
Warwickshire
CV34 5GJ

telephone

01926 889955

more info

www.jnpgroup.co.uk/contact

Bristol

Whitefriars,
Lewins Mead,
Bristol

BS1 2NT

telephone

01174 721705

more info

www.jnpgroup.co.uk/contact