

Proposed Site Layout - Scale 1/500

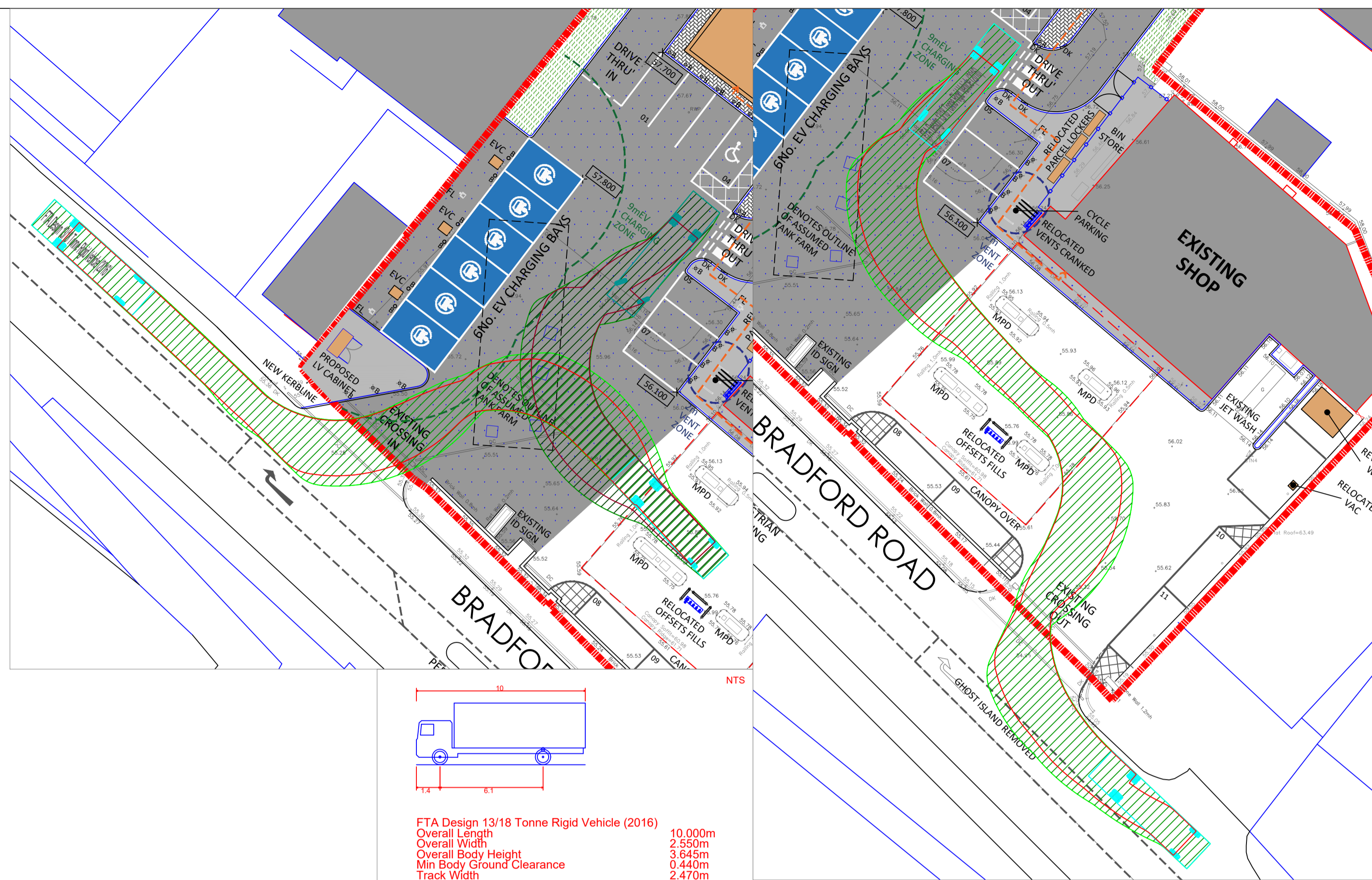

Swept Path Analysis - 10m Rigid - Scale 1/250

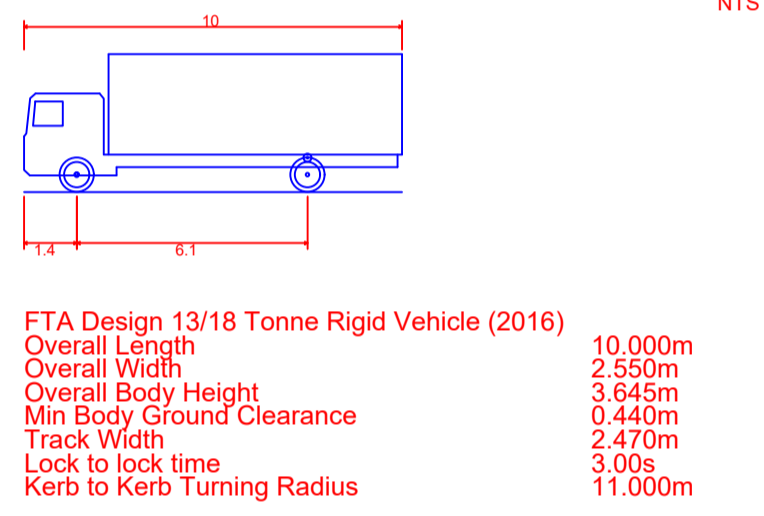

Swept Path Analysis - Oil Tanker - Scale 1/250

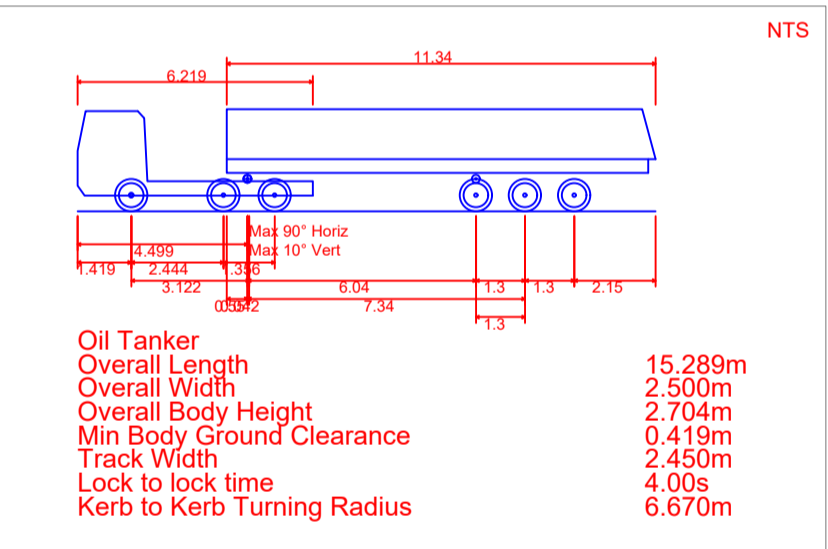
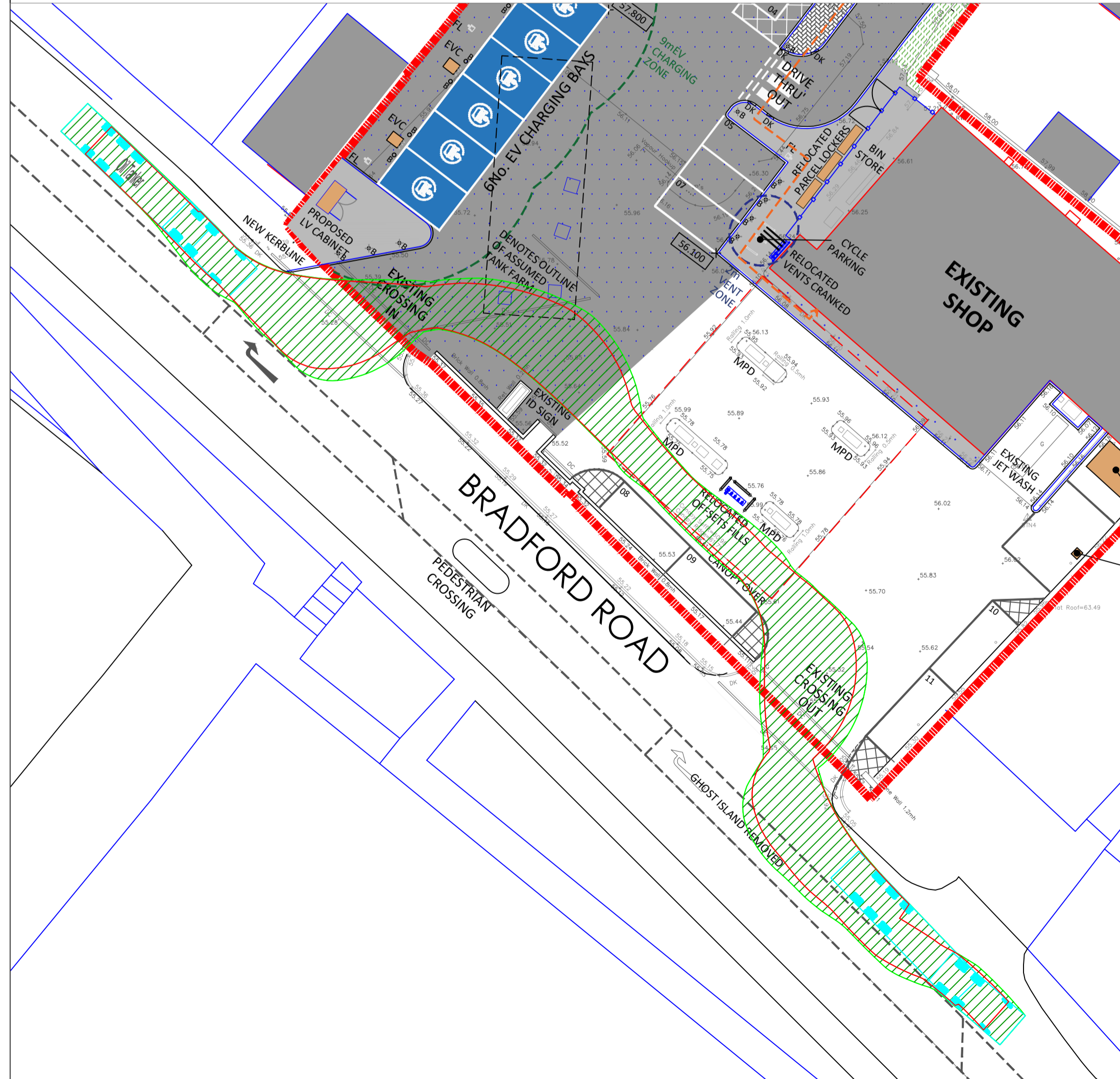

Swept Path Analysis - Large Car - Scale 1/200

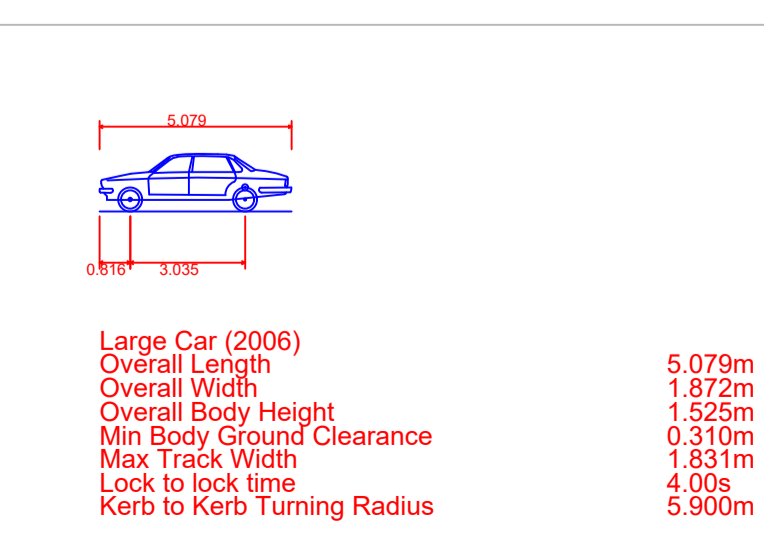
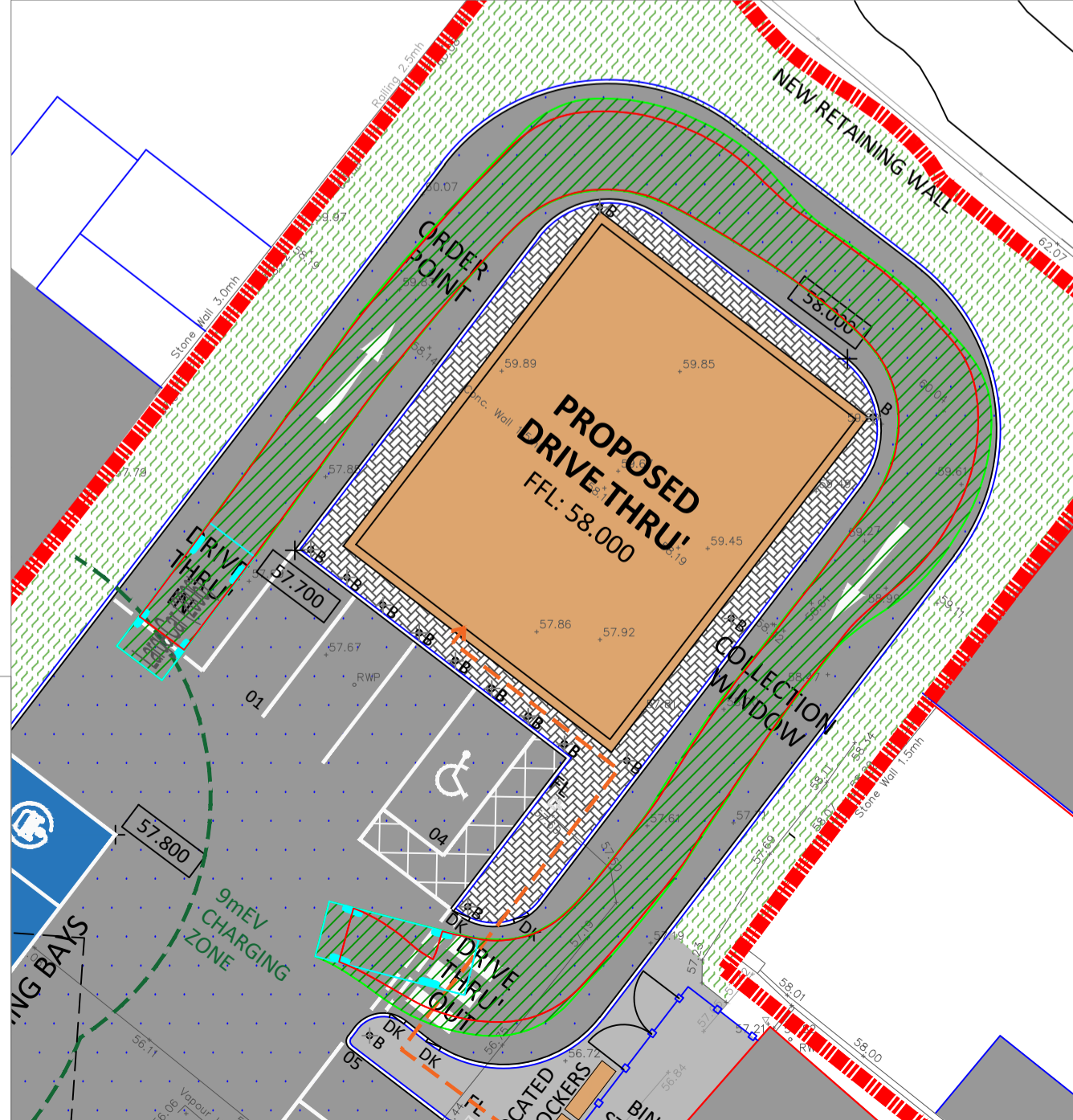

Notes
 All levels are stated in metres.
 This drawing is to be read in colour.
 All dimensions are stated in millimetres unless noted otherwise.
 Drawing provided for technical approval, NOT to be used for construction purposes.
 DTP are not responsible for the accuracy of data provided by clients or third parties.

Rev.	Date	Revisions	Drawn
A	01/06/26	Architect Layout Update	SA
-	21/05/26	First Issue	SA

+44 (0) 7411 751 693
 www.dynamictransportplanning.co.uk
 enquiries@dynamictransportplanning.co.uk

Client
Darwen Investment Ltd

Project
Proposed Drive-Thru Unit Development, A652 Bradford Road, Batley

Drawing Title
Proposed Site Layout Swept Path Analysis Oil Tanker, 10m Rigid & Large Car

Date	May 2026	Scale	As Specified @ A1
Drawn	SA	Approved	GS

Drawing Number
DTP/3707526/ATR001

Rev.
A