

**Operating principle**

In addition to anaerobic digestion taking place in the primary settlement chamber (2) the Ensign unit allows the clarified water to pass into a second 'aerobic' chamber (3) where it is treated to remove the dissolved constituents. Here aerobic bacteria supported by diffused air and mobile media, ensures full treatment is achieved before the treated effluent and sloughed off bacteria flows to a final settlement chamber (3). The final effluent is then discharged to the drainage field or watercourse via a Polylok filter.

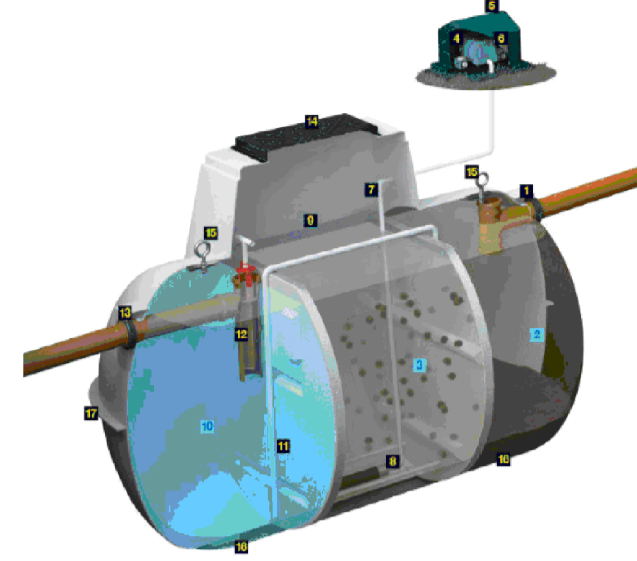

**KEY**

1. Inlet
2. Primary settlement chamber
3. Aeration chamber
4. Compressor with alarm
5. Compressor housing (if external or internal optional)
6. BCD 3 electrical connection
7. PVC pressure pipe for diffusers
8. Bio media
9. Stainless steel mesh
10. Final settlement chamber
11. Sludge return
12. Unique Polylok tertiary filter (Only on Ensign Ultra units)
13. Outlet
14. Access lid
15. Integral lifting eyes
16. Stabilising feet
17. Unique tying-in lip

**Foul Water Treatment unit - Typical detail**

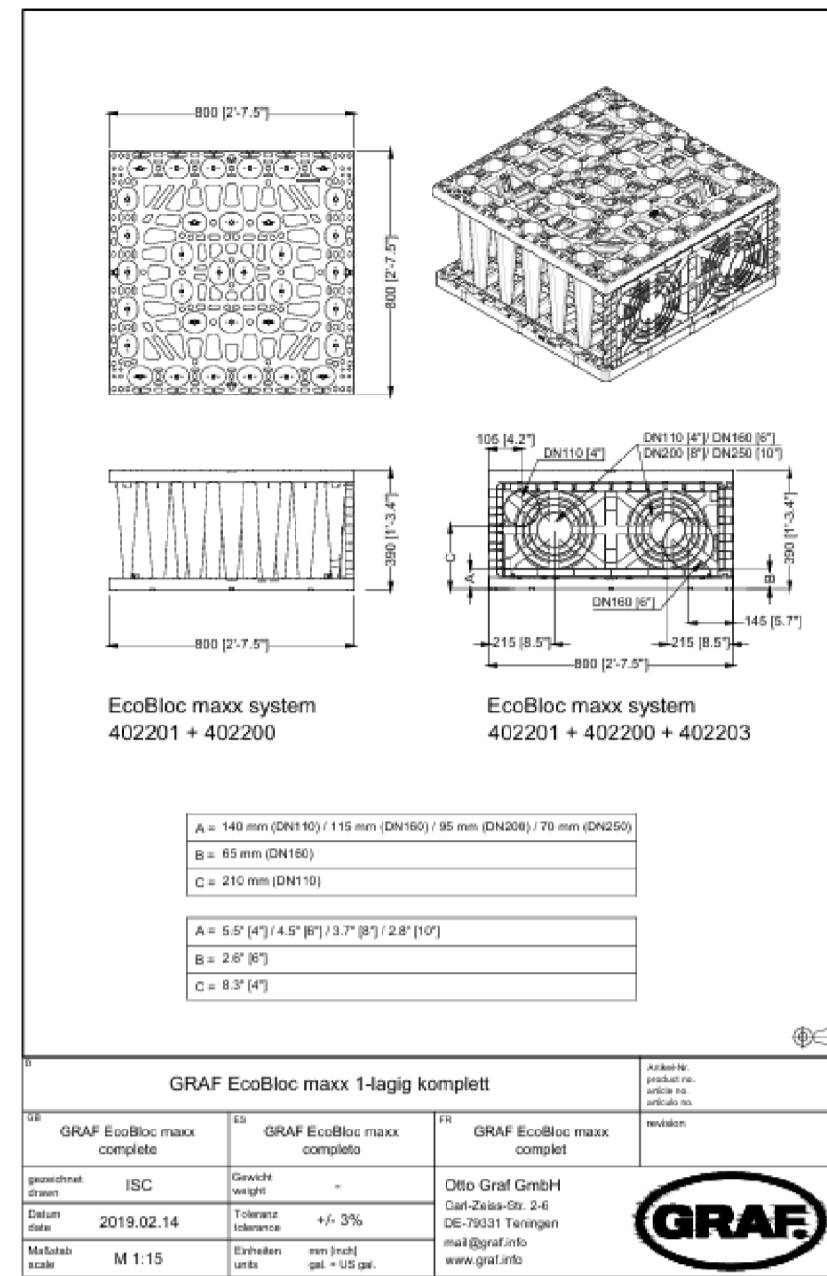

**Graf Ecobloc Maxx detail - Crate Attenuation**

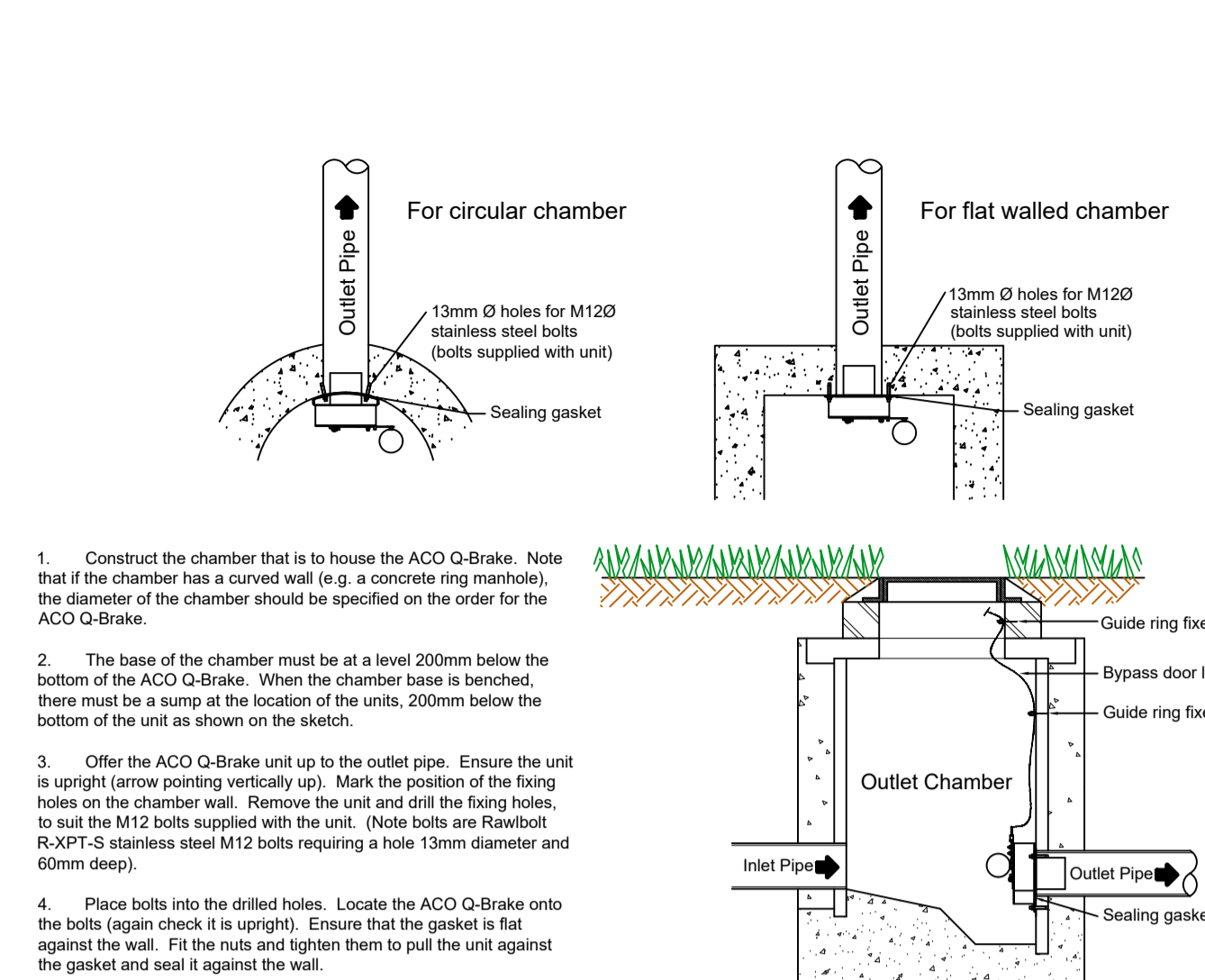

1. Construct the chamber that is to house the ACO Q-Brake. Note that if the chamber has a curved wall (e.g. a concrete ring manhole), the diameter of the chamber should be specified on the order for the ACO Q-Brake.
2. The base of the chamber must be at level 200mm below the bottom of the ACO Q-Brake. When the chamber base is finished, there must be a sump at the location of the units, 200mm below the bottom of the unit as shown on the sketch.
3. Offer the ACO Q-Brake unit up to the outlet pipe. Ensure the unit is upright (arrow pointing vertically up). Mark the position of the fixing holes on the chamber wall. Remove the unit and drill the fixing holes to suit the M12 bolts supplied with the unit. (Note bolts are Rawbol R-XT-S stainless steel M12 bolts requiring a hole 13mm diameter and 60mm deep).
4. Place bolts into the drilled holes. Locate the ACO Q-Brake onto the bolts (again check it is upright). Ensure that the gasket is flat against the wall. Fit the nuts and tighten them to pull the unit against the gasket and seal it against the wall.
5. Fix the two wire guide rings (supplied) to the chamber wall, one approximately mid height and one just under the access cover. Thread the bypass door lifting wire through the rings. Adjust the length of the wire by fixing the handle in the correct position and cutting the cable to length.

**ACO Q-Brake detail - Flow Control Unit**

**General Notes**

- Do not scale this drawing. If in doubt, consult with the Engineer
1. This drawing is to be read in conjunction with all other relevant Engineers, Architects and Specialist design drawings and specifications.
  2. All dimensions and levels are in metres unless noted otherwise.
  3. This drawing is for information purposes and all information displayed is subject to detailed design.
  4. Cover levels noted are indicative or best design levels. constructed levels should take into account as-built surfacing levels and gradients.
  5. The Contractor shall be responsible for checking all fix-ins for line and level with existing foul and surface water systems before commencing any works.
  6. The Engineer shall be notified immediately, in writing, should any errors or discrepancies be found prior to the commencement or continuation of any works. All work is to be carried out in accordance with current British Standards, Building Regulations and NHBC Standards.
  7. All drainage work is to be strictly in accordance with the requirements of the Building Regulations 2010, Approved Document Part H, 'Drainage and waste disposal'.
  8. It is the responsibility of the Contractor to execute the works at all times in strict accordance with the requirements of the Health and Safety at Work Act 1974, and the C.D.M. Regulations 2015. The Contractor will be deemed to have allowed for full compliance, including full liaison with the Principal Contractor, within his rates.
  9. All existing land drains encountered on site during construction are to be re-connected.
  10. Should any departure from the proposed slab or external level be considered, agreement shall be sought from the Engineer immediately and prior to the commencement or continuation of any works. Proposals should take full account of all restrictions to the slab level.
  11. Temporary protection to be provided to drainage work during construction as necessary.
  12. Power supply to separator/treatment units, alarm, panel, vent etc to be provided by contractor in accordance with manufacturers recommendations.
  13. Topographical survey shown is based upon Creative Planning surveys drawing BR-001
  14. Architects layout shown is based upon Creative Planning drawing CP0028-BR-001. This layout may be subject to change and is intended for indicative purposes only.

**Specification Notes**

15. The following types of pipe may be used unless noted or agreed otherwise:
  - Pipes up to 300mm diameter to be Structured Wall to BS EN 13476, Polypropylene to BS EN 1552 or PVC-U to BS EN 1401.
  - Pipes 300mm diameter or over to be Concrete to BS 5911.
16. Both Clay and Concrete pipes shall be strength class 120 (100/150mm min crushing strength 28kN/m). Thermoplastic pipes shall have a minimum ring stiffness of SM4.
17. Pipes which run adjacent to buildings shall be installed in strict accordance with Part H, Clauses 2.23 to 2.25.
18. All pipes, chambers and fittings shall be installed, bedded and backfilled in accordance with the manufacturers instructions subject to the following minimum requirements:
 

| Pipe Location             | Cover to crown | Clay/Concrete Pipe Bedding | Plastic Pipe Bedding | Backfill                 |
|---------------------------|----------------|----------------------------|----------------------|--------------------------|
| Roads (HGV)               | >1.2m          | Class S                    | Class S (S10r2)      | Type 1 Granular          |
| Drives / car parking      | >0.9m          | Class 'A' (Concrete)       | Class 'A' (Concrete) | Type 1 Granular          |
| Hard and soft Landscaping | >0.6m          | Class S (Concrete)         | Class S (S10r2)      | Suitable as dug material |

19. The first flexible joint in pipes adjoining a manhole shall be a maximum length of 600mm from the inside face of the manhole, connecting to a rocker pipe. The length of the rocker pipe shall be as follows:

| Pipe diameter | Length of Rocker pipe |
|---------------|-----------------------|
| 150-600mm     | 600mm                 |
| 675-750mm     | 1000mm                |
| over 750mm    | 1250mm                |

20. All manholes and inspection chambers situated in areas subject to vehicular loading to have class D400 covers and frames to BS EN124 and those not subject to vehicular loading to have class minimum class B125 covers and frames.
21. Drainage frames must be tied to manhole risers by use of manufacturers ties (eg. Polypipe ref FRK500 fixing kit and FRK501 black ties.) The ground works contractor will be held fully responsible for any accidents due to incorrect fitting or failure to use the correct manufacturers fixing equipment.
22. All drains in the vicinity of existing or proposed trees to be constructed in accordance with the requirements of NHBC Practice Note 3.

