

Elevation A-A

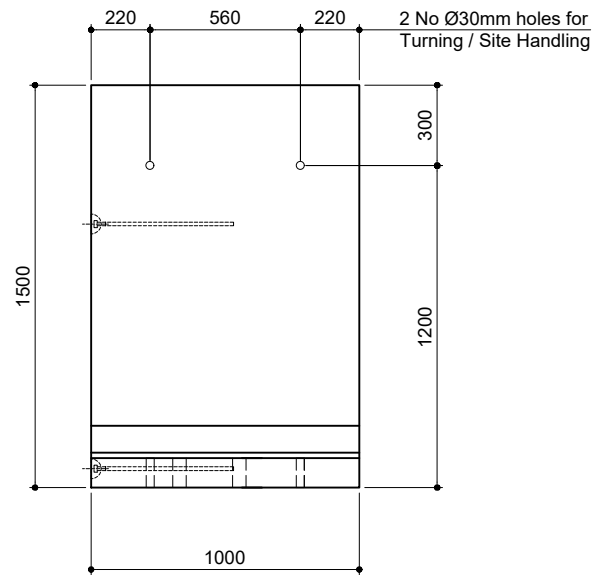

Elevation B-B

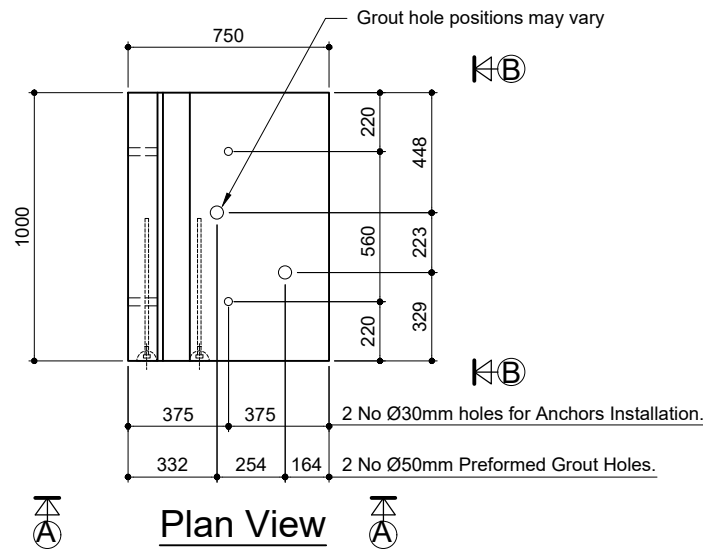

Plan View

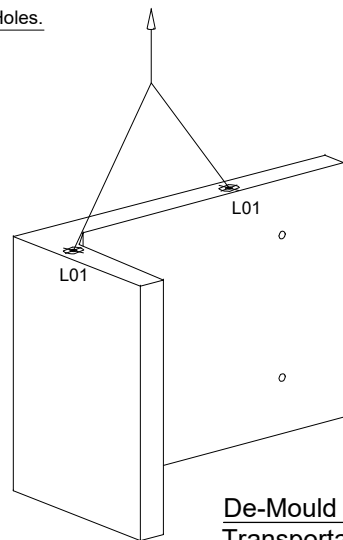

De-Mould and Transportation Diagram (nts)

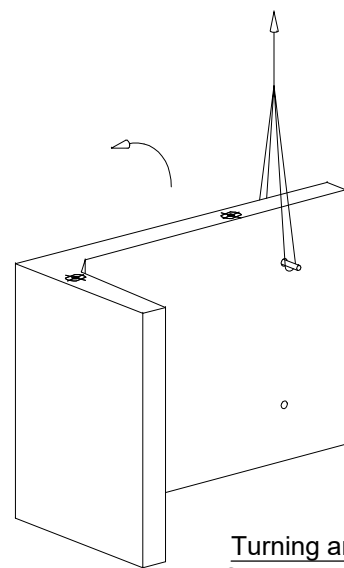

Turning and Site Handling Diagram (nts)

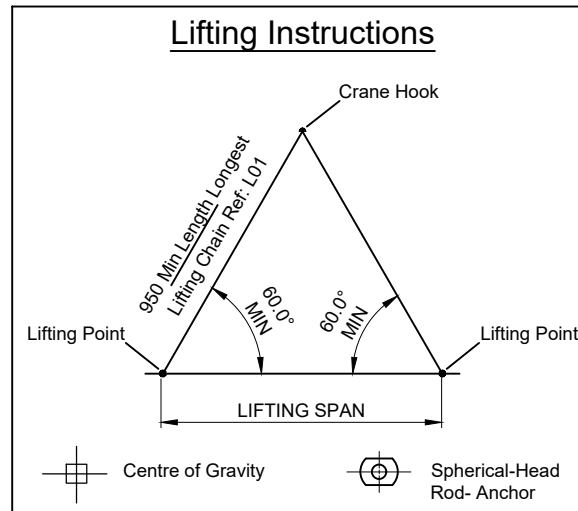

Lifting Instructions

Centre of Gravity Spherical-Head Rod-Anchor

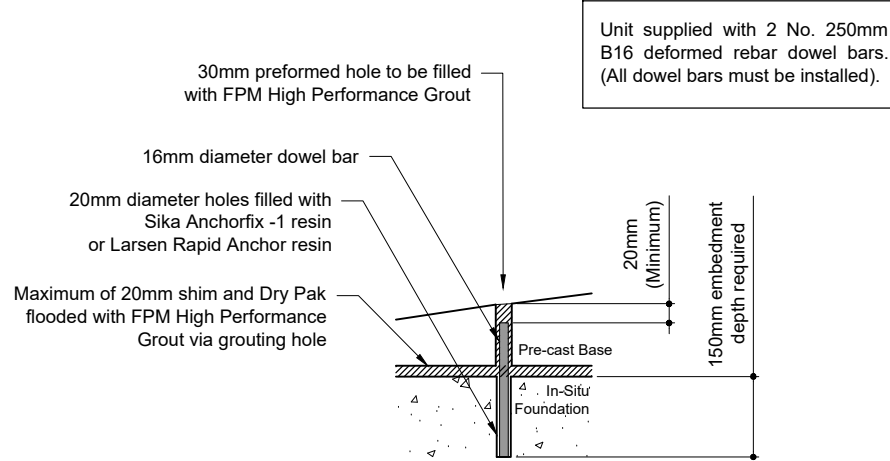

Anchor Detail Scale 1:10

- Installation steps:**
- Position the units on to the shimmed concrete foundation.
  - Dry Pak to the edge of the base of the units to create a seal to the perimeter.
  - Through the 30mm preformed holes drill a 150mm, 20mm diameter hole into the foundation.
  - Fill holes with the resin to a level so that when the dowels are inserted the resin becomes level with the top of the foundation (as a minimum).
  - Insert the B16 dowel bar into the resin. Ensure that the bar is pushed to the base of the drilled hole.
  - Ensure the units are uniformly supported by using the grouting hole to completely flood the shimmed void (and grouting hole) with grout.
  - Grout around the dowel so that the dowel is completely encapsulated.
  - Do not disturb dowel bar or unit until grout has achieved full strength in accordance with resin and grout manufacture guidelines.

- The Construction (Design and Management) Regulations 2015**
- If you are unsure of your responsibilities please refer to the HSE website.
  - These notes should be read by all CDM duty holders. Whilst we do not go into specifics such as working at heights, working over excavations, slips and trips etc, where  $\Delta$  is shown in the notes and on the drawing some potential hazard / risks are identified and should be assessed accordingly by the main contractor and the design team prior to any site works commencing.
  - Particular attention should be made to the notes identified by  $\Delta$  which have the potential for significant risk where not adhered to. This F.P. McCann unit drawing should be read in conjunction with all other relevant drawings available from the design team e.g Architect, Engineer, Steelwork sub-contractor etc.
  - Lifting** - The lifting equipment referred to in note 1 is the only lifting equipment which should be used on F.P. McCann supplied units. All elements must be lifted in accordance with F.P. McCann's lifting plan/method statement.
  - Installation** - Where it is necessary to work at height i.e. removal of shackles, procedures for working at heights must be followed. The manufactures guidelines and safety recommendation for the application of the grout and resin must be followed.

- Notes:**
- Handling**
    - Unit Volume / Weight

Unit Ref	Volume (m <sup>3</sup> )	Weight (T)	Weight + 5% (T)
1500 Wall Unit	0.26	0.68	0.71

Weight is based on 2.5 T/m<sup>3</sup>.  
+5% is recommended for sizing lifting equipment.
    - All lifting points shall be used as specified below:

As-Cast Lift	Qty	Simply Reference	SWL (T)
Sph. Head Rod Anchors	2	STRA025520	2.5

Upright Lift	Qty	Reference
Wire Rope Lifters	2	Rope Assemblies - A18 Master Link

Anchor recesses to be filled by others on site.
    - The site lifting / installation equipment may be purchased from Simply Precast (Tel: 0800 678 5178).  
Site Lifting: Pin Anchor Lifting Shackle Ref: SPARC025.
  - Concrete**
    - Lifting strength based on 2 cubes = 15 N/mm<sup>2</sup>.
    - Characteristic 28 day cube strength = 55 N/mm<sup>2</sup>.
    - Concrete provides Design Chemical Class 2 (DC2) to Special Digest 1, Table D2.
  - Reinforcement**
    - Reinforcement (500B or C) to BS4449.
    - Scheduling, dimensioning, bending and cutting to BS8666.
    - Cage to be tack welded and/or tied with 17 gauge annealed tying wire.
  - Manufacture**
    - Manufactured to BS EN 13369:2013.
    - Tolerances based on BS EN 13369:2013 & BS EN 13670:2009.
    - Finishes: As below unless indicated otherwise on drawing

Class	Cast Edge		All Other Faces
	Steel Float	A	
    - Marking: Units shall be indelibly marked to show:
      - Unit reference and date of manufacture
      - Unit weight + 5%
  - Design**
    - Design to BS EN 1992-1-1:2004 & BS EN 1997-1:2004.
    - Application of the wall to conform to standard loading conditions(8) or to be verified (by Others) to be suitable based on noted wall capacities (7). Loading of the wall during construction must be considered.
    - F.P. McCann have designed the concrete units only, the stability of the support conditions should be checked by overall scheme designer.
    - Design Life: >100 years to BS8500.
    - Cover to Reinforcement & Exposure:

Min Cover	Cover Block Size (mm)	Min Cover (mm)	Max Cover (mm)
All Faces	45	40	50
  - Foundation**
    - Concrete base to be designed and installed (by others).
    - To ensure good bond and satisfy cover requirements in the anchors the slab should have minimum strength of C20 / C25 and a minimum depth of 250mm.
  - Retaining Wall Capacity**
    - Sectional moment capacity at analysis position (top of haunch) = 6kNm/m run (in both directions).
    - Sectional moment capacity above 2nd analysis position = 6kNm/m run (in both directions)
  1. Analysis position 1 (top of haunch) 230mm.  
2. Analysis position 2 750mm
  - Stabilizing action from backfill material to be assessed on the unit weight of backfill (where applicable).
  - Resistance to overturning from fixing when loaded to the rear (over the heel) about the leading edge = 7kNm/m run.
  - Resistance to overturning from fixing when loaded to the front about the leading edge = 7kNm/m run.
  - Shear resistance at foundation = 110kN/m run.
- Standard Loading Conditions**
  - Four Loading conditions considered: -
    - Loaded to rear with level fill and live load surcharge.
    - Loaded to front with level fill and live load surcharge.
    - Loaded to rear with 20° sloped fill.
    - Loaded to front with 20° sloped fill.

Construction loading must not be more onerous than the permanent condition.
- The backfill material should be free draining granular material such as a class 6N or 6P, fill as define in the manual of Contract Documents for Highway Works Volume 1 Specification Series 600 Clause 610 & table 6/1.  
Characteristic effective shearing resistance  $\phi = 35^\circ$ ,  
Unit weight of fill = 19kN/m<sup>3</sup>
- Live Load 10.0kN/m<sup>2</sup>

Rev	Date	Revision detail	By	Chk'd
H	Dec/23	Grout notes updated	AS	SH
G	April/23	Grout notes updated	AS	SH
F	Feb/22	Notes updated	AS	SH

Manufacture Tolerances	
Allowable dimensional variations shall not exceed the following:	
Length/Height	Cross section (each direction)
Length $\pm$ 6mm	$\pm$ 6mm
Height $\pm$ 6mm	
Edge straightness (deviation from intended line)	
$\pm$ 6mm	
Holes	
Size of hole or opening:	+ 5/-0
Location of holes:	$\pm$ 25mm

**MC fpmccann**  
 F.P. McCann  
 Lydney Industrial Estate, Harbour Road  
 Lydney, Gloucestershire, GL15 4EJ  
 Tel: 01594 847500  
 Fax: 01594 847501  
 www.fpmccann.co.uk

Contract / Title: **F. P. McCann Standard Retaining Wall Straight L Wall 1.5m High General Arrangement**

Drawn: LK    Scale: 1:20, 1:10    Status: Manufacture  
 Date: 14/12/16    Chk'd: SH    Feb, 2022

Drawing no: **FPM-SLW-1.5-GA**    Rev: **H**