

REF: Domino's Mirfield

47 Huddersfield Road

Mirfield

WF14 8AE

Date 30th January 2025 update 26th March 2025

1.0 INTRODUCTION

2.0 PREAMBLE TO PIZZA TAKEAWAY SPECIFICATION

3.0 DETAILED DESIGN OF VENTILATION SYSTEM

3.1 Canopy Hood.

3.2 Extraction

3.3 Speed Controls

3.4 Make up Air System

3.5 Water heater within air in system

3.6 Silencers

3.7 Odour Control

3.8 Filter Specification

3.9 Dwell Time

3.10 Extraction Duct Work Brief

3.11 Make Up Air Ductwork Brief

3.12 External Cowl with Air Velocity

3.13 Proposed Elevations

3.14 Odour Risk Assessment

3.15 Gas inter-lock System

4.0 Cold room and Airconditioning compressor data sheets

1.0 INTRODUCTION:

The information contained within this document should be used as supporting information when applying for Change of Use Planning Approval and is based on *BESA – Building Engineering Services Association, Guidance on the control of odour and noise from Commercial Kitchen Exhaust system*. This follows feedback from various Local Authorities who using BESA / EMAQ Control of Odour and Noise From Commercial Kitchen Exhaust Systems as a guide when referring to the extract system as part of the application process.

The advises that the aim of any ventilation/extraction is to ensure that no nuisance, disturbance or loss of amenity is caused by odour, fumes, food droplets or noise, to nearby properties.

Additionally, the visual appearance of the flue may be important and the flue itself may require a separate planning permission. Enquiries should be made to the Local Authority Planning Department regarding this matter.

A suitably qualified and experienced person with specialist knowledge of ventilation schemes should undertake the design and installation of a ventilation system.

Designing and installing appropriate ventilation systems may involve considerable

expense.

In circumstances where the end user of the premises is unknown, or where the specific type of food to be cooked is unknown, the installation should be designed to achieve the highest level of odour control in order to cater for a worst-case scenario.

There are many different types of odour abatement available (carbon filters, electrostatic precipitation, high dilution and high velocity extraction) however not all types are suitable for all cooking methods. In each case, grease filters must be installed.

2.0 PREAMBLE TO PIZZA TAKEAWAY SPECIFICATION

Please note that a Pizza takeaway produces very little grease and the extract system is predominately removing heat and gas combustion fumes. All work is carried out in accordance with the latest relevant British (or Irish regulations where applicable) and European Standards, statutory Regulation and Byelaws together with the following publications:

CIBSE Codes and guides to current practice

Water Authority By Laws

BESA - DW143 Practical Guide to Ductwork Leakage Testing

BESA - DW144 Specification for Sheet Metal Ductwork

BESA - DW172 Guide to Good Practice for Kitchen Ventilation Systems

BESA - RUAG70 Guide to Good Practice Refrigeration

The Building Regulations

Gas Safety (Installation and Use) Regulations 1998

All plant, ducts, pipe cables etc. shall be adequately protected against accidental damage corrosion and external environment and shall be capable of safe decontamination and removal in the future without disturbing other services. Pipes and ducts shall be adequately sized, kept as short as practicable, leak-proof with a minimum number of joints and have provision for routine maintenance. All facilities shall be designed to prevent the ingress or egress of rodents, vermin, and insects.

The duct will be fixed to the shell of the unit using anti-vibration fixing mounts and under no circumstances will flexible ductwork be used other than the fan connections

The HVAC contractor shall supply the client with system design drawings, prior to manufacture and installation

For projects in England and Wales, the HVAC contractor shall also demonstrate compliance with Building Regulations Approved documents L2A & L2B. This will include:

- (a) Provision of details of the efficiency and controls of heating, cooling and ventilation systems in accordance with Non-Domestic & Heating, Cooling and Ventilation compliance Guide (2006)
- (b) Provision of commissioning certificates including air leakage tests on the ductwork

The HVAC contractor shall ensure that externally the ductwork conforms to the supplied drawings in terms of its route, height and termination. These drawings will have formed part of our Planning Approval and will be built as such.

Upon completion of the installation, all shall be fully tested and proved including airflows. The contractor shall produce an Operating and Maintenance Manual which shall contain details of all equipment supplied, a record drawing of the complete mechanical services installation and copies of all Test Certificates. It shall contain a Maintenance Schedule based on the manufacturer's recommendations.

3.0 DETAILED DESIGN OF VENTILATION SYSTEM

3.1 Canopy Hood. Supplied by Whites

Canopy dimensions are 3131mm wide x 1359 Deep

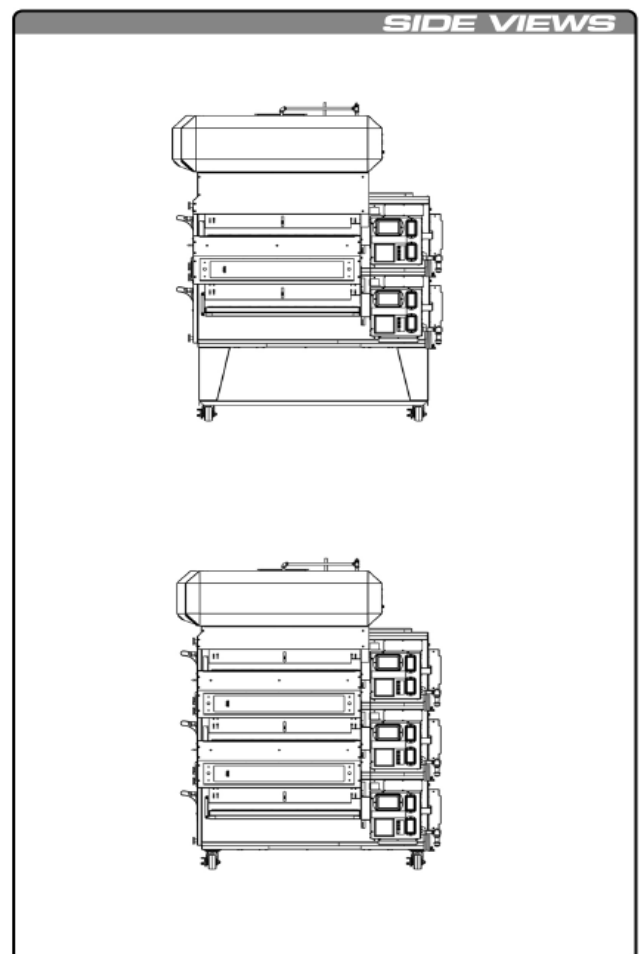
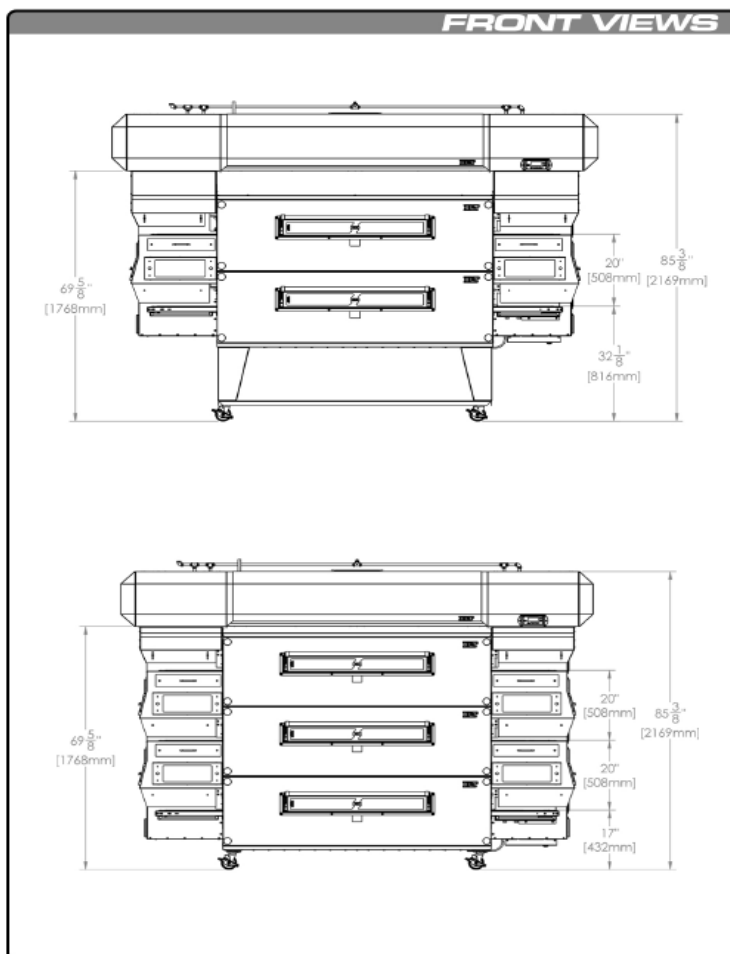
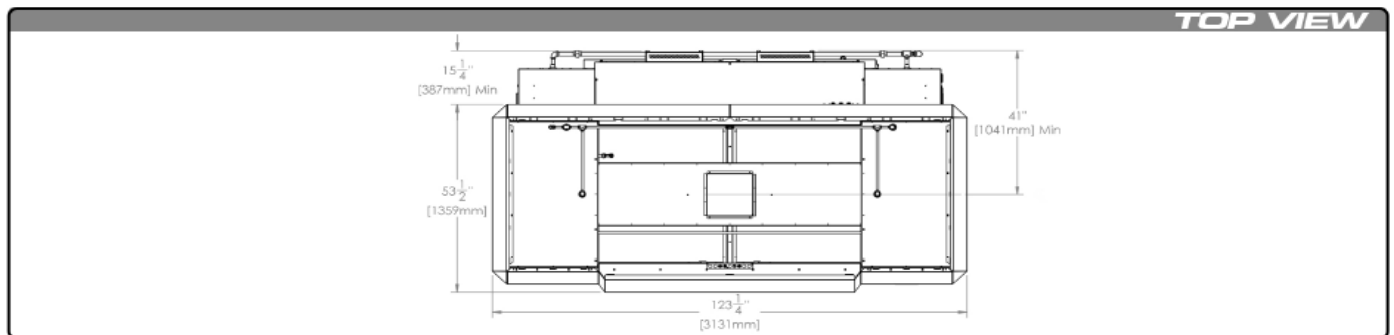

3870H**MODEL**
F-Version**XLT**
SmartSolutions™**DATA SHEET****F-VERSION HOOD FOR XLT 3870 OVEN****ELECTRIC UTILITY SPECIFICATIONS**

<i>Inputs Into Electrical</i>		
	Standard	World
VAC	208/240 VAC	230 VAC
Amps	3 Amps	3 Amps
Hz	60 Hz	50 Hz
Phase	1 Phase	1 Phase

*Do not connect to 3 phase power. 1 phase only.

<i>Output From Electrical</i>	
The XLT Hood System Provides:	
Up to three (3) switching outputs for HVAC damper and/or dedicated unit.*	
One (1) 230 VAC, 4.3 Amp, variable frequency, three (3) phase power output for the ventilation exhaust fan. (Maximum output: 10 Amp)*	
Relocation cord will physically connect into oven.	
One (1) 24 VDC fire alarm signal.*	Up to three (3) receptacles for ovens.

*VFD only.

HOOD AND SHROUDS WEIGHT

Hood and/or Shrouds Only	<i>Hood Only</i>		<i>Hood & Shrouds</i>			
	lbs	kg	<i>Double</i>		<i>Triple</i>	
			lbs	kg	lbs	kg
	453	205	703	319	775	352

EXHAUST FLOW RATES

	<i>Double Stack</i>	<i>Triple Stack</i>
CFM (All Ovens On)	800	1140
M3/Min (All Ovens On)	22.65	32.28
Efficiency Comparison	17.18% More Efficient Than E-Version	22.08% More Efficient Than E-Version

*Figures represent TOTAL VOLUME measured at the duct (Minimum recommended). Refer to XLT Ovens I&O Manual for full complete information.

EXHAUST FAN AND CURB

Dimensions	<i>Specs</i>					
	inches	mm	inches	mm	inches	mm
	31	787	31	787	67	1702
Crated Weight (Stacked)	lbs	kg				
	185	84				

OVEN & HOOD WARRANTY

<i>USA & Canada (Parts & Labor)</i>	<i>International (Parts & Labor)</i>
10 Years Oven & Hood Combo Purchase*	7 Years Oven & Hood Combo Purchase
7 Years Standard	5 Years Standard

*Pre-piped fire suppression system must be purchased on each oven and hood.

3.2 Extraction**Extraction fan**

The fan specified in the extraction system is a Soler and Palau CVAT/4-6000/450 D, rpm 1465, sound pressure level 63 outlet dBA, pressure level air volume 5.620(m³/h),

This fan will be fitted with an inverter single phase in, three phase out.

The fan will be fitted with anti-vibration mountings to the ceiling and DEC flexible connections between the fan and silencers; this will stop any reverberation noise travelling back through the ceiling or floors.

Fan duty 1.38m³/sec @ 250pa static pressure.



ACOUSTIC CABINET FANS

CVAB/T-ND Series



Range of direct drive backward curved centrifugal cabinet fans designed for ventilation of commercial kitchens and industrial applications. Cabinet fan manufactured from aluminium profiles and double thickness side panels internally lined with 25 mm thickness of fireproof fiberglass acoustic insulation. Circular duct connection flange on the inlet and outlet. CVAB-N/CVAT-N incorporates direct drive backward curved centrifugal impeller, manufactured from aluminium (CVAB-N) or steel (CVAT-N) sheet, with motor fitted inside the air stream.

Motors

CVAB-N
Single-phase external rotor motors 230V 50Hz, IP55, class F, with thermal protection, speed controllable by tension. Working temperature from -40°C to 60°C.

CVAT-N
Three-phase 4 and 6 pole motors 230/400V 50Hz, IP55, class F, with thermal protection (PTC), speed controllable by inverter. Working temperature from -20°C to 40°C.

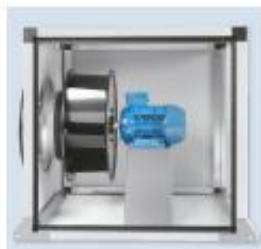

Backward curved centrifugal impellers
To prevent accumulation of dirtiness. Dynamically balanced.

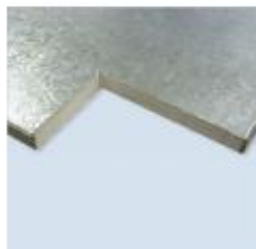

Low noise level
Double thickness side panels lined with 25 mm thickness of fireproof fiberglass acoustic insulation.



Robustness
Quality finished aluminium profiles and plastic corners providing a great robustness.

Specific applications



Industrial kitchens

ACOUSTIC CABINET FANS CVAB/T-ND Series

TECHNICAL CHARACTERISTICS

Before installation check that the product electrical characteristics listed on the data plate label (voltage, power, frequency, etc.) match those of the intended electrical supply.

Model	Speed (rpm)	Maximum absorbed power (W)	Maximum absorbed current (A)	Maximum air flow (m ³ /h)	Sound pressure level* (dB(A))			Weight (kg)
					Inlet	Radiated	Outlet	
SINGLE-PHASE 4 POLES								
CVAB/4-1400/250N D	1300	107	0,5	1280	49	44	50	13,0
CVAB/4-2000/315N D	1390	169	0,7	1820	53	47	54	13,0
CVAB/4-3000/355N D	1370	312	1,3	2800	58	51	58	30,0
CVAB/4-4000/400N D	1390	557	2,3	4210	62	54	60	32,0
CVAB/4-6000/450N D	1380	930	4,0	6140	64	57	63	46,0
CVAB/4-9000/500N D	1390	1289	5,5	7580	68	61	66	58,0
THREE-PHASE 4 POLES								
CVAT/4-1400/250N D 0,18	1480	116	0,5	1.230	50	37	48	13,0
CVAT/4-2000/315N D 0,18	1460	169	0,5	1.830	54	41	53	13,0
CVAT/4-3000/355N D 0,18	1430	251	0,5	2.660	56	43	56	30,0
CVAT/4-4000/400N D 0,37	1445	438	0,9	3.850	60	47	60	32,0
CVAT/4-6000/450N D 0,75	1465	747	1,7	5.620	63	50	64	46,0
CVAT/4-9000/500N D 1,1	1480	1347	2,5	7.900	67	53	68	58,0
CVAT/4-12000/560N D 2,2	1470	2093	4,2	11.100	69	56	71	82,0
CVAT/4-16000/630N D 3	1460	3234	5,9	14.640	72	60	75	113,0
THREE-PHASE 6 POLES								
CVAT/6-15000/710N D 1,5	970	1828	3,6	14.320	72	60	74	149,0

* Sound pressure level measured in free field condition at 1.5m, at the medium working point on the performance curve, shown 2, 5, 8 and 11.

Model	VFKB	
	1-PHASE SUPPLY	3-PHASE SUPPLY
CVAT/4-1400/250N D 0,18	VFKB-24	VFKB-45
CVAT/4-2000/315N D 0,18	VFKB-24	VFKB-45
CVAT/4-3000/355N D 0,18	VFKB-24	VFKB-45
CVAT/4-4000/400N D 0,37	VFKB-24	VFKB-45
CVAT/4-6000/450N D 0,75	VFKB-24	VFKB-45
CVAT/4-9000/500N D 1,1	VFKB-24	VFKB-45
CVAT/4-12000/560N D 2,2	VFKB-27	VFKB-48
CVAT/4-16000/630N D 3	VFKB-27	VFKB-48
CVAT/6-15000/710N D 1,5	VFKB-27	VFKB-48

DIMENSIONS (mm)

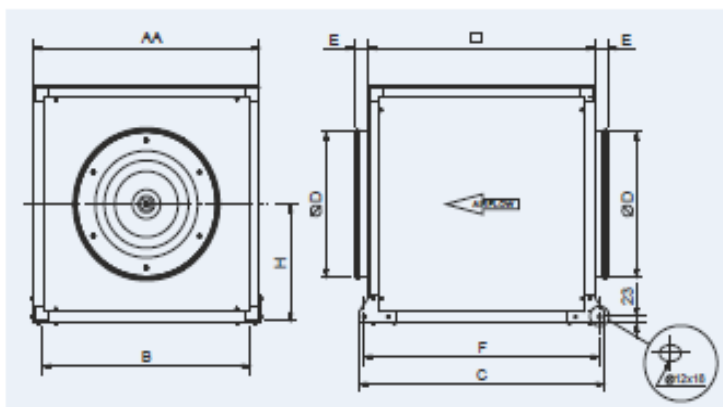

Model CVAB - CVAT	A	B	C	D	E	F	H
1400/250N D	500	457	574	250	58	534	250
2000/315N D	500	457	574	315	58	534	250
3000/355N D	650	607	724	355	58	684	325
4000/400N D	650	607	724	400	58	684	325
6000/450N D	750	707	824	450	58	784	375
9000/500N D	800	757	874	500	58	834	400
12000/560N D	900	826	977	560	58	937	450
16000/630N D	1000	959	1077	630	58	1037	500
15000/710N D	1100	1059	1177	710	58	1137	550

3.3 Speed Controls

Speed Control Inverter Extraction

Single phase in, three phase out, the inverter works using single phase in 240V and splits it over three 240v phase to the fan.

This will also be fitted with a stop/start with cook and prep control.

Air-in control REB 5

Both extraction and makeup air system will be fitted on time clocks, the system will shut down when the store closes.



47. Remove the front panel of the enclosure by removing the panel fixing screws. This provides access to the control circuit board terminals that are inside the enclosure. Replace the panel when the wiring connections have been made, ensuring that the seal is correctly positioned.
48. Check that the unit mountings and electrical connections are secure and in accordance with the applicable wiring diagram on page 6 (and if applicable, page 7 also) of this instruction booklet.
49. For wiring diagrams of other schemes, please contact S&P.
50. IF IN DOUBT, ASK!

WIRING DIAGRAMS (SINGLE PHASE 230V - 50Hz MAINS SUPPLY)
 L - Supply Live 230V - 50Hz
 N - Supply Neutral
 E - Earth

WIRING DIAGRAM No. 1 - ON/Off to installer-defined speed and thereafter manual speed adjustment via the Inverter's integral keypad.

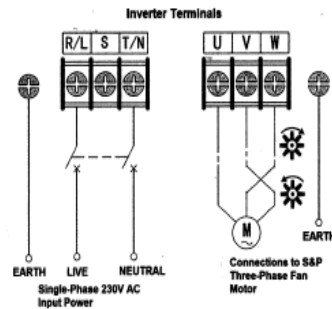

IMPORTANT NOTE TO INSTALLERS!
 THE PACKAGED 3-PHASE FAN SUPPLIED WITH THIS INVERTER HAS BEEN CONFIGURED TO ACCEPT A 3-PH 230V SUPPLY, NOT A 400V SUPPLY - IT IS ESSENTIAL THAT THE FAN IS NOT RE-CONFIGURED.
 IF IN DOUBT, ASK!

WIRING DIAGRAM No. 2 - Operation Mode b, Off/On and speed control by additional accessory S&P REB-CVF 0-10V Speed Controller code S&P5401304100.

NOTE - WIRING DIAGRAM No.2 is IN ADDITION TO WIRING DIAGRAM No.1

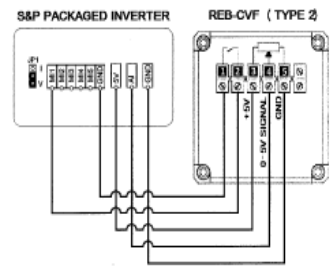
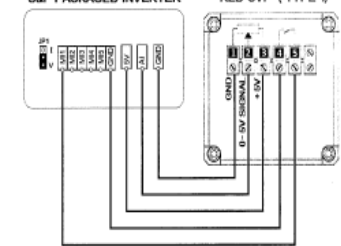

In addition to Wiring Diagram No. 1, Wiring Diagram No.2 plus the "Programming the Inverter" sequence on page 9 of this instruction booklet must be followed.

Air input controller REB 5



stop/start with cook and prep control for extraction

3.4 Make up Air System

The fan specified in make-up air system is Soler and Palau CBM/6-320/240-550W, rpm 900, sound pressure level 67 inlet dBA @ 0 Metres, air volume 4700(m³/h), This fan will be fitted with a REB 5 speed control. Pre filter 496mm x 496mm G4. Code PPF49649647 The fan will be fitted with anti-vibration mountings this will stop any reverberation noise travelling back through the ceiling. Fan duty 1.3m³/sec @ 200 pa static pressure.

LOW PRESSURE CENTRIFUGAL FANS



CBM Range



Range of double inlet direct drive low pressure centrifugal fans manufactured from **galvanised sheet steel**. All the models are fitted with forward curved centrifugal impellers manufactured from galvanized sheet steel. Available, depending upon the model, with single phase or three phase motors, in 4 or 6 poles.

Motors

All standard motors (1) are IP10, Class B, equipped with thermal protection and ball bearings greased for life.

Electrical supply:

Single phase 230V-50Hz (capacitor fitted on the fan housing).

Three phase 230/400V-50Hz .
(See characteristics chart).

(1) Except CBM-380/380 fitted with an aluminium housing closed motor IP44 class F.

Additional Information

Mounting feet as accessory, allowing 4 different positions.

On request

Aluminium housing closed motors, IP44, class F (T version).

Coupling flange fitted at the fan outlet (B version).

Anti-vibration mounts



All motors are fitted with support including rubber antivibration mounts **reducing the noise** transmitted to the installation

Impeller dynamically balanced



Impeller **dynamically balanced**, according to ISO 1940 standard, providing vibration free operation

A P P L I C A T I O N S



Incorporation in ventilation cabinets



Air conditioning equipment

P O S I T I O N S

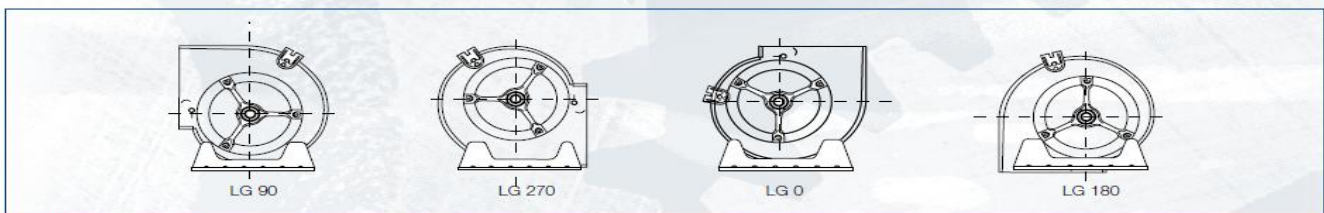

Mounting feet (accessory) allow 4 positions of the inlet discharge.

■ Technical characteristics

Before installation check that the product electrical characteristics listed on the data plate label (Voltage, power, frequency etc) match those of the intended electrical supply.

Model	Motor power		Equiv. in inches	Poles	Speed (r.p.m.)	Capacitor (µF / V)	Maximum current absorbed 230/1/50 (A)	Maximum current absorbed 230-400/3/50 (A)	Airflow (m ³ /h)	Sound pressure level * (dB(A))	Weight (kg)
	(W)	(PK)									
CBM/6-180/180-72W	72	1/10	7/7	6	960	4/400	1,0	-	1400	56	9
CBM/4-180/180-147W	150	1/5	7/7	4	1350	6/400	1,5	-	1565	59	10
CBM/6-240/180-122W	120	1/6	9/7	6	900	8/500	2,1	-	2430	63	15
CBM/6-240/180-245W	250	1/3	9/7	6	920	10/450	2,45	-	2680	65	16
CBM/6-240/240-122W	120	1/6	9/9	6	850	8/500	2,1	-	2500	61	16
CBM/6-240/240-245W	250	1/3	9/9	6	900	10/450	2,75	-	2900	63	17
CBM/4-240/240-373W	370	1/2	9/9	4	1350	10/400	3,8	-	2650	65	19
CBM/6-270/200-245W	250	1/3	10/8	6	900	10/400	3,0	-	3480	65	18
CBM/6-270/200-373W	370	1/2	10/8	6	970	15/400	4,0	-	4000	68	19
CBM/4-270/200-373W	370	1/2	10/8	4	1300	12/400	5,0	-	3150	66	21
CBM/6-270/270-245W	250	1/3	10/10	6	900	10/400	3,0	-	3550	63	20
CBM/6-270/270-373W	370	1/2	10/10	6	900	15/400	4,0	-	4500	67	21
CBM/4-270/270-550W	550	3/4	10/10	4	1400	15/400	5,9	-	3540	66	23
CBM/6-320/240-550W	550	3/4	12/9	6	900	18/400	5,8	-	4700	67	28
CBM/6-320/240-1100W (trif.)	1100	1,5 (3f)	12/9	6	900	-	-	7,0/4,2	7000	75	28
CBM/6-320/320-550W	550	3/4	12/12	6	900	18/400	5,8	-	5250	66	30
CBM/6-320/320-1100W (trif.)	1100	1,5 (3f)	12/12	6	900	-	-	7,0/4,0	7900	78	30
CBM-RTC/6-380/380-2200W (trif.)	2200	3 (3f)	15/15	6	940	-	-	10,4/6,0	9000	70	45

* Measured at 1.5 meters at the fan inlet side in free field

3.5 Water Heater within the air in system

VBR 70-40-3 WATER HEATING BATT

Item no. 5476

Document type: Product card

Document date: 2019-03-12

Generated by: Systemair Online Catalogue

Description

Water-heating battery

Water-heating battery for heating air in ventilation systems with rectangular ducts. Hot-zinc-coated casing, heat transmission element with copper tubes and aluminium fins. In cold conditions, a frost protection device with sensor should be fitted to reduce the risk of damage from freezing. The water-heating battery can be installed in a horizontal or vertical duct with an optional direction.



Technical parameters

Max. operating temperature	150 °C
Max. operating pressure, at water temp. 100°C	1600000 (16bar) Pa
Max. operating pressure, at water temp. 150°C	1000000 (10bar) Pa

AIRGARD® Type II Pleated Panel Filters



AIRGARD® TYPE II FEATURES:

- Moisture resistant cardboard frame.
- G4 efficiency to provide a good base level of filtration.
- Fully supported media bonded to expanded mesh grid.
- The filtering media is bonded to the case to eliminate air by-pass.
- Strong, robust construction.
- Extended surface area.
- High dust holding capacity.
- Dimensions of product are part marked into frame for positive ID.

APPLICATIONS

- Hotels
- Offices
- Food production
- Air conditioning
- Hospitals
- Pre-filtration asbestos removal

AIRGARD® TYPE II PLEATED PANEL FILTER

Used in a variety of HEVAC applications where higher level air cleanliness is needed over the standard pre filters. Glass media is unacceptable in food and pharmaceutical industries and in some hospital areas. Especially useful where the installation requires a combination of high arrestance coupled with control over smaller particles. The high capacity version is selected when space is at a premium; filter sizes match the rated capacities of bag filters.

CONSTRUCTION / MATERIAL SPECIFICATIONS

The Airgard® Type II is manufactured with pleated synthetic media, and an expanded diamond grid with 97% open area. The casing is constructed from a heavy duty rigid water resistant card, with support members along the diagonals. The media is bonded to the support grid and the frame in order to avoid the possibility of air bypass. The case is designed for minimum resistance and maximum free area, the case is also crease formed to stop moisture ingress. The product can be manufactured in a variety of depths from 22mm to 97mm deep. Optional metal frame available as shown above.

- 22mm (1") Filters are 9 Pleats per 300mm (1ft)
- 47mm (2") Filters are 9 Pleats per 300mm (1ft)
- 97mm (4") Filters are 9 Pleats per 300mm (1ft)

TYPE II HIGH CAPACITY PLEATED PANEL

We are able to manufacture the Type II with increased filter media over the standard product, for situations where an increase in air volume is required.

- 22mm (1") Filters are 12 Pleats per 300mm (1ft)
- 47mm (2") Filters are 12 Pleats per 300mm (1ft)
- 97mm (4") Filters are 12 Pleats per 300mm (1ft)

TYPE II HIGH EFFICIENCY PLEATED PANEL

Where situations arise we manufacture the Type II with a higher grade of filter media, F6, F7, F8 are available.

AIRGARD® TYPE II IMPREGNATED CARBON PLEATED PANELS

For less demanding situations the use of impregnated media can be considered. They utilise non-woven synthetic media, which is then impregnated with activated carbon. They offer an alternative to our granular carbon systems however they cannot offer either the life span or dwell time that can be found with the rest of the range.

AIRGARD® Type 11 Pleated Panel Filters

FITTING INSTRUCTIONS

- Fit products, observe direction of airflow indicator

HANDLING

- Handle with care when unpacking.
- Store in dry and frost protected place.

MAINTENANCE

- All maintenance and replacement schedules will be set by the original equipment installer. Please refer to this for more information.
- When handling any components suitable PPE should be used – gloves, eye protection and access equipment should be used where required.
- Filters should not be cleaned but replaced when required in accordance with maintenance schedule set by the installation contractor.

PACKAGING

All units are packaged in double wall boxes, glued closed for protection whilst in transit against contamination.

TECHNICAL SPECIFICATIONS

SIZE ORDERING GUIDE (TOLERANCES +/- 2mm)				
Part Number	Actual Size HxWxD	Nominal Size HxWxD	Weight	Available Efficiencies *
PPF24824822	248 x 248 x 22mm	254 x 254 x 25mm	0.07kgs	G4, F6, F7, F8, High Capacity, Carbon Impregnated Pleated Panels
	9.76 x 9.76 x 0.87"	10 x 10 x 1"	0.15lbs	
PPF49624822	496 x 248 x 22mm	508 x 254 x 25mm	0.14kgs	G4, F6, F7, F8, High Capacity, Carbon Impregnated Pleated Panels
	19.53 x 9.76 x 0.87"	20 x 10 x 1"	0.31lbs	
PPF29329322	293 x 293 x 22mm	304 x 304 x 25mm	0.09kgs	G4, F6, F7, F8, High Capacity, Carbon Impregnated Pleated Panels
	11.54 x 11.54 x 0.87"	12 x 12 x 1"	0.21lbs	
PPF59429422	594 x 294 x 22mm	609 x 304 x 25mm	0.19kgs	G4, F6, F7, F8, High Capacity, Carbon Impregnated Pleated Panels
	23.39 x 11.57 x 0.87"	24 x 12 x 1"	0.41lbs	
PPF37537522	375 x 375 x 22mm	381 x 381 x 25mm	0.15kgs	G4, F6, F7, F8, High Capacity, Carbon Impregnated Pleated Panels
	14.76 x 14.76 x 0.87"	15 x 15 x 1"	0.34lbs	
PPF49637522	496 x 375 x 22mm	508 x 381 x 25mm	0.19kgs	G4, F6, F7, F8, High Capacity, Carbon Impregnated Pleated Panels
	19.53 x 14.76 x 0.87"	20 x 15 x 1"	0.41lbs	
PPF49639622	496 x 396 x 22mm	508 x 406 x 25mm	0.20kgs	G4, F6, F7, F8, High Capacity, Carbon Impregnated Pleated Panels
	19.53 x 15.59 x 0.87"	20 x 16 x 1"	0.43lbs	
PPF62039622	620 x 396 x 22mm	635 x 406 x 25mm	0.24kgs	G4, F6, F7, F8, High Capacity, Carbon Impregnated Pleated Panels
	24.41 x 15.59 x 0.87"	25 x 16 x 1"	0.53lbs	
PPF44844822	448 x 448 x 22mm	457 x 457 x 25mm	0.19kgs	G4, F6, F7, F8, High Capacity, Carbon Impregnated Pleated Panels
	17.64 x 17.64 x 0.87"	18 x 18 x 1"	0.42lbs	
PPF49649622	496 x 496 x 22mm	508 x 508 x 25mm	0.24kgs	G4, F6, F7, F8, High Capacity, Carbon Impregnated Pleated Panels
	19.53 x 19.53 x 0.87"	20 x 20 x 1"	0.52lbs	
PPF59649622	596 x 496 x 22mm	609 x 508 x 25mm	0.27kgs	G4, F6, F7, F8, High Capacity, Carbon Impregnated Pleated Panels
	23.46 x 19.53 x 0.87"	24 x 20 x 1"	0.60lbs	
PPF62049622	620 x 496 x 22mm	635 x 508 x 25mm	0.28kgs	G4, F6, F7, F8, High Capacity, Carbon Impregnated Pleated Panels
	24.41 x 19.53 x 0.87"	25 x 20 x 1"	0.63lbs	
PPF59659622	596 x 596 x 22mm	609 x 609 x 25mm	0.31kgs	G4, F6, F7, F8, High Capacity, Carbon Impregnated Pleated Panels
	23.46 x 23.46 x 0.87"	24 x 24 x 1"	0.68lbs	
PPF24824847	248 x 248 x 47mm	254 x 254 x 50mm	0.12kgs	G4, F6, F7, F8, High Capacity, Carbon Impregnated Pleated Panels
	9.76 x 9.76 x 1.85"	10 x 10 x 2"	0.26lbs	

Pressure drop and airflow information available on request.

3.1 Silencers.

Two silencers will be fitted to the extraction system, inflow side this silencer will be 600mm long, x 450mm 1D (inside measurement) wall thickness of 50mm.

On the outflow side will be a 600mm long, x 450mm inside diameter 1D (inside measurement) wall thickness of 50mm.

Silencer Ref: Extraction SIL 450-600 450 560 1000 2D Positive side
 SIL 450-600 450 560 600 1D Negative side

Air in system SIL 450-600 450 560 600 1D Negative side

The sound level at termination point will be a lowered by a further 3 to 5 dBA due to where the fan will be mounted with in the ductwork.

Circular silencers

SIL

[Download Wentyle](#)
[Download AlnorCAM](#)
[Buy via B2B](#)



Description

The silencers are usually supplied with SPIRAL®system sealing. Diameters $d_1 > 315$ mm require additional NSL couplings to be ordered, which should be installed in the silencer prior to installation. These male ends are not silencer parts, and they should be ordered separately.
 Glass mineral wool inside with thickness:
 50 mm d1a SIL-50 - depending on the dimension of the outer casing
 100 mm d1a SIL-100 - depending on the dimension of the outer casing

Example identification

Product code: **SIL - iii - aaa - bbb**
 type _____
 insulation thickness _____
 $\varnothing d_1$ _____
 L _____

Dimensions

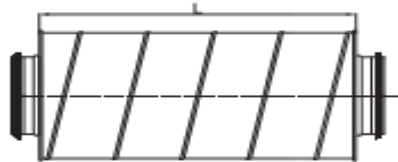
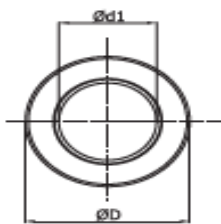

Cross-section for individual types: SIL, SIRC, $d_1 \leq 315$ mm.

Not applicable diameters: D-100, D-125, D-160, D-200, D-250 - in the embodiment of the insulation thickness of 50 mm.

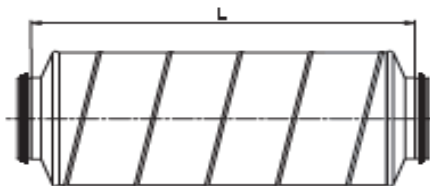
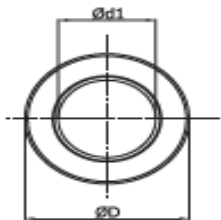

Cross-section for silencers: SIL, SIRC in the embodiment of the insulation thickness of 50 mm and applicable diameters: D-100, D-125, D-160, D-200, d-250.

Silencers made with pressed reductions.

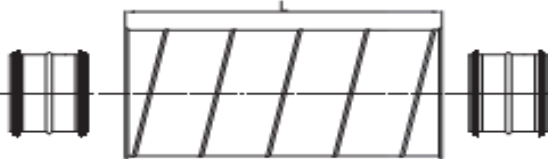
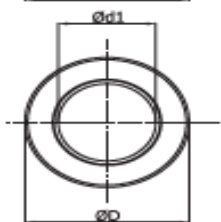

Cross-section for individual types: SIL, SIRC, $d_1 > 315$ mm

Circular silencers

SIL

[Download Wentyle](#)
[Download AlnorCAM](#)
[Buy via B2B](#)

Dimensions

SIL-50 - 50 mm thickness insulation

Description	Ød, nom [mm]	D nom [mm]	L [mm]	attenuation [dB] for frequency [Hz]								[kg]
				125	250	500	1000	2000	4000	8000		
SIL 080-300	80	180	300	6	15	29	45	50	26	28	2	
080-500	80	180	500	9	18	32	48	53	29	31	3	
080-600	80	180	600	11	19	33	49	54	30	32	3	
080-900	80	180	900	13	22	36	52	57	33	35	5	
080-1000	80	180	1000	14	23	37	53	58	34	36	6	
080-1200	80	180	1200								7	
SIL *100-300	100	200	350	5	13	26	41	44	22	24	2	
*100-500	100	200	550	8	16	29	44	47	26	27	3	
*100-600	100	200	650	9	17	30	45	49	27	29	3	
*100-900	100	200	950	12	19	32	48	51	29	31	5	
* 100-1000	100	200	1050	13	21	34	49	52	30	32	6	
* 100-1200	100	200	1250								7	
SIL *125-300	125	224	350	4	11	22	37	41	19	21	3	
*125-500	125	224	550	7	14	26	40	44	22	24	4	
*125-600	125	224	650	8	15	27	41	45	24	25	4	
*125-900	125	224	950	11	18	29	44	47	26	28	7	
* 125-1000	125	224	1050	12	19	31	45	49	27	29	7	
* 125-1200	125	224	1250								9	
SIL 150-300	150	250	300	4	11	23	34	36	18	19	4	
150-500	150	250	500	7	14	26	37	39	21	22	4	
150-600	150	250	600	8	15	27	39	41	22	23	6	
150-900	150	250	900	11	18	29	42	43	25	26	8	
150-1000	150	250	1000	12	19	30	42	44	26	27	8	
150-1200	150	250	1200								10	
SIL *160-300	160	250	350	3	9	20	33	35	16	18	3	
*160-500	160	250	550	6	12	23	36	38	19	21	5	
*160-600	160	250	650	7	14	24	37	39	21	22	6	
*160-900	160	250	950	10	16	26	40	42	23	25	8	
* 160-1000	160	250	1050	11	17	28	41	43	24	26	8	
* 160-1200	160	250	1250								10	
SIL *200-300	200	300	350	2	7	16	31	31	15	16	4	
*200-500	200	300	550	5	10	19	34	34	18	19	6	
*200-600	200	300	650	6	11	20	35	35	19	20	7	
*200-900	200	300	950	8	13	23	38	38	22	23	10	
* 200-1000	200	300	1050	9	15	24	39	39	23	24	11	
* 200-1200	200	300	1250								12	
SIL *250-500	250	355	550	4	9	18	29	27	15	16	9	
*250-600	250	355	650	5	11	19	30	28	16	18	11	
*250-900	250	355	950	8	13	22	33	31	19	20	14	
* 250-1000	250	355	1050	9	14	23	33	32	20	21	12	

SIL-50 - 50 mm thickness insulation

Description	Ød, nom [mm]	D nom [mm]	L [mm]	attenuation [dB] for frequency [Hz]								[kg]
				125	250	500	1000	2000	4000	8000		
* 250-1250	250	355	1200	11	17	25	35	34	21	23	17	
* 250-1550	250	355	1500	12	18	26	37	35	23	24	20	
SIL 300-500	300	400	500	4	8	16	25	23	13	15	13	
300-600	300	400	600	5	10	18	27	25	14	16	15	
300-900	300	400	900	7	12	20	30	27	17	18	16	
300-1000	300	400	1000	8	13	21	30	28	18	19	19	
300-1200	300	400	1200	10	15	23	32	30	20	21	22	
300-1500	300	400	1500	12	17	24	34	32	21	23	25	
SIL 315-500	315	400	500	4	7	14	23	21	13	14	11	
315-600	315	400	600	5	8	16	25	19	14	15	12	
315-900	315	400	900	7	11	18	28	21	17	18	16	
315-1000	315	400	1000	8	12	19	28	22	18	19	16	
315-1200	315	400	1200	10	14	21	30	24	19	21	19	
315-1500	315	400	1500	12	16	23	32	26	21	22	25	
SIL 355-600	355	450	600	4	9	16	22	17	13	14	13	
355-900	355	450	900	7	11	19	25	19	16	17	18	
355-1000	355	450	1000	8	12	20	26	21	17	18	20	
355-1200	355	450	1200	10	15	22	27	22	18	20	22	
355-1500	355	450	1500	11	16	23	29	24	20	21	27	
SIL 400-600	400	500	600	4	8	15	20	15	12	13	15	
400-900	400	500	900	6	10	18	23	17	15	16	20	
400-1000	400	500	1000	8	12	19	24	18	16	17	22	
400-1200	400	500	1200	9	14	21	25	20	17	19	25	
400-1500	400	500	1500	11	15	22	27	22	19	20	31	
SIL 450-600	450	560	600	4	8	16	18	13	12	12	23	
450-900	450	560	900	6	11	18	21	16	15	15	27	
450-1000	450	560	1000	7	12	19	22	17	16	16	29	
450-1200	450	560	1200	9	14	21	23	18	17	17	31	
450-1500	450	560	1500	11	16	23	25	20	19	19	36	
SIL 500-600	500	600	600	3	7	14	17	11	11	12	32	
500-900	500	600	900	6	9	16	20	14	13	14	42	
500-1000	500	600	1000	7	11	17	21	15	14	15	51	
500-1200	500	600	1250	9	13	19	22	17	16	17	59	
500-1500	500	600	1500	10	14	20	24	18	17	19	72	

3.7 Odour Control

Unit size 1200mm D x 600mm H x 1200mm W

Constructed from galvanised steel with access doors to remove and replace the filters

Cleaning schedule

Pre-filter 2 x 595 x 595 Mesh filter

Cleaning period once a month

Pre- filter 2 x 595 x 595 G4 filter

Change once a month

Carbon bag filters 2 x 595 x 595

Change every six months

LONGAR® Type 4 Mesh Filter

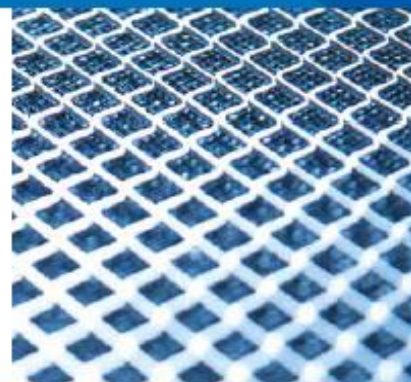

LONGAR® TYPE 4 FEATURES:

- The LONGAR® Type 4 Mesh filter is manufactured using a patented expanded mesh, this offers a unique design based on many years of R&D. This results in a mesh that delivers greater air or grease arrestance, integral strength and low pressure loss.
- Comes with a safety edge channel to offer greater strength and safety over conventional products available on the market place.
- Using an Expanded metal multi-layer pad we are able to offer a panel with greater rigidity and importantly the pad cannot migrate particles, which can be found in 'knit mesh' filters, these types of panels can be hazardous where strands can break away from the filter.
- Due to the nature of the material that we use, its Integral strength means when it comes to cleaning it will stand up well, and outlast panels of lesser constructions.
- Tested to Eurovent 4/5.
- Handles and drain holes are available.
- Available in Galvanised Steel, Stainless Steel and Aluminium.

APPLICATIONS

- Primary air filtration G2/G3
- Kitchens
- Cooker hoods
- All types of grease extraction
- General heating and ventilation pre-filtration

LONGAR® TYPE 4 MESH FILTER

The LONGAR® Type 4 Mesh filter is the result of years of experience in the manufacture and development of filters for the HEVAC world. With over 40 years of manufacturing experience the products brought to the market place today are clearly world class in price and product.

The LONGAR® Type 4 is a superior grease filter, available in a large selection of sizes and materials options.

Our Mesh filters are of robust construction and are used for a variety of applications, grease and air or dust collection applications, coalescer and spark arrestance, ideal as a prefilter for large particle contaminants and widely used in high air volume applications.

CONSTRUCTION DETAILS / MATERIAL SPECIFICATION

Media: Expanded metal patented design to aid filtration, available in stainless steel, galvanised steel, and aluminium.

Frame: U shaped section supplied with safety edge, available in stainless steel, galvanised steel and aluminium.

Filter thickness: Filter panels are available in actual thicknesses of: 8,10,12,20,25,40,45,50 and 95mm. Other sizes available on request.

Support mesh: Our own Q14 mesh is used in the grease filter as the support mesh.

Handles and drain holes: Folding handles and drain holes can be supplied as an option when required. They are fitted by default to the short dimension, unless otherwise stated by the customer at the time of ordering.

Housings: We can supply front withdrawal housings where required, see separate data sheet.

For technical specifications, part numbers and ordering information, please see overleaf.

FITTING INSTRUCTIONS

- Fit products, handles in direction of air in.
- Product vertical in air stream.
- Drain holes lower edge to exit into drip tray if installed.

HANDLING

- Handle with care when unpacking.
- Store in dry and frost protected place.

MAINTENANCE

- All maintenance should be carried out in accordance with the planned maintenance set by installation contractor.
- When handling any components suitable PPE should be used - gloves, eye protection and access equipment.
- Filters should be cleaned by a trained operative either daily for heavy use or weekly for light use.
- For more exact guide to cleaning you should contact a cleaning specialist.

PACKAGING

All units are packaged in double wall boxes with separators for standard sizes, glued closed for protection whilst in transit against contamination.

TECHNICAL SPECIFICATIONS

Tested to Eurovent 4/5

Fire rating = UL Class 2

100% relative humidity

Longar specifies the Grease Filter as height x width x thickness. The handles are fixed to the height and drain holes punched on the width.

Please ensure correct orientation is given when ordering.



Carbon Impregnated Bag Filters

Applications

The Activated Carbon impregnated bag filter, can be utilised to remove the slight general odours associated with towns and cities.

When a Carbon Bag Filter is used in the extract systems of light duty catering establishments, such as coffee shops, the life of it will be very short, as the odour retention is directly proportional to the weight of activated carbon on the product.

Airclean will not recommend this product for new installations for odour removal.

Description

The fully cured coating of the activated carbon powder on the polyester non-woven bag filter material is formed into pockets which are stitched and tagged to minimise blinding from each other.

The formed pockets are supported by a copper coated rod assembly which, with the media, is sealed into the corrosion resistant galvanised steel header frame.

Technical

Filter Classification:
 Maximum Operating Temperature : 40 Degrees Centigrade
 Maximum Operating Humidity: 80% RH



STANDARD CARBON IMPREGNATED BAG FILTERS

Dimensions					Flow Rate		Part Numbers
OT Inches		Actual mm			Flow	Pressure Drop	
H x W	D	H	W	D	m³/s	Pa	
24 x 12	12	594	289	289	0.38	70	1410801
	20	594	289	492	0.47	70	1410804
24 x 20	12	594	492	289	0.50	70	1410802
	20	594	492	492	0.64	70	1410805
24 x 24	12	594	594	289	0.75	70	1410803
	20	594	594	492	0.94	70	1410806
NON STANDARD							1410899



Front Withdrawal Frame



MEZ Flanged Side



Duct Mounted Filter



Fully Welded Side



3.8 Dwell time 0.2 sec

3.10 Extraction Duct Work Brief

Extraction duct work

The ducting systems will be mounted above the suspended ceiling running from the canopy, with the fan and silencers hung from ant-vibration to the ceiling, stopping any vibration traveling through the ceiling.

From the canopy the ducting will be in 300mm x 600mm rectangular changing into 450mm SPT to the fan and silencers, the ducting will stay to same ducting 450mm SPT then changing as it passes through the window into fire rated ducting. The ducting will travel up the rear elevation wall to 1 meter above the roof line terminate with a jet cowl.
duct runs as shown on plans.

3.11 Make Up Air Duct Work Brief

The air supply will be mounted above the suspended ceiling, the air will be brought into the store through a weather louver grille 500mm x 500mm mounted through the wall on the side elevation. The air will be distributed through 600mm x 600mm four-way ceiling grilles.

Makeup air system as shown on the below plans.

This system will give 80% volume of the extraction system, 85% volume of the extracted air is required to be replaced by mechanical air supply fan and controller discharging through surface mounted grilles or sufficient free area space ie: windows or doors open with fly screens to give air replacement.

Ducting ColourGalvanised

CowlJet Cowl

Discharge velocity on the cowl 12-15m3/s

All our systems comply with DW175 regulations and specifications with regards to ducting sizes, heights and fan duties etc.

The Commissioning sheet will be issued after the work has been completed showing air flow rate and inventory of the system fitted.

Air in

Weather louver grille

Grille sizes,500mm x 500mm



Extraction cowl



Spiral Tube

450mm x 450mm Fire rate ducting will be used for the Extraction system on the rear elevation of the store.



2 and 4-hour fire-rated ductwork

Lindab Thor Duct® BS476 fire-rated ductwork has been designed to cater for the various fire safety requirements within the building industry today.

The ventilation of buildings creates potential fire risks as ducts penetrate compartments, resulting in the possibility of fire and smoke spreading to areas of a building, separate from the fire location. The prevention of fire spreading through ducted systems is of critical importance.



BS476 Part 24 (1987) and ISO6944 (1985) is a fire test on building materials to determine the fire resistance of ventilation ducts. Evidence of the ability of a ductwork system to resist the spread of fire whilst maintaining its stability and integrity as a ductwork system is demonstrated.

The correct use of fire-rated ductwork will maintain fire compartmentation and assist in the safe dispersal of hazardous smoke and fumes. BS476 fire resisting ducts will facilitate escape and fire fighting.

Lindab Thor Duct® BS476:

- Square, Round and Flat Oval
- Tested BS476 part 24:1987
- A complete system, tested with insulation
- 400°C Uninsulated test
- One, two and three sided ducts
- Galvanised steel, mild steel and stainless steel
- Tested with insulation to meet DW172 requirements on Kitchen Extract and Smoke Extract (multi-compartment)

Thor Duct® is a complete system with fire resisting access doors and fire resisting silencers.

Performance of Lindab Thor Duct[®] BS476

Fire resisting ductwork may need to pass through compartment walls or floors that will have a prescribed fire resistance period in terms of the load-bearing capacity (stability), integrity and insulation criteria, for durations of 30 to 240 minutes.

The standard periods of stability and integrity should in all cases be at least equal to those required for the penetrated element of construction. Lindab Thor Duct[®] BS476 has been tested and provides up to 240 minutes to meet even the most challenging requirements.



Application	Stability and Integrity			
	120 minutes	240 minutes	Type A	Type B
Smoke control	✓	✓	✓	✓
Pressurisation	✓	✓	✓	✓
Kitchen	✓	✓	✓	✓
Passive/Compartmentation	✓	✓	✓	✓

Lindab Thor Duct[®] has been independently tested by the following notified bodies; Warrington Exova In the UK, Applus Laboratories Barcelona.

Lindab Thor Duct[®] is also approved by Applus Laboratories under the requirements of SPC-117. Approved for use in the Middle East.

Lindab Thor Duct[®] has certification of approval through the certifier scheme, the property of Warrington Exova.

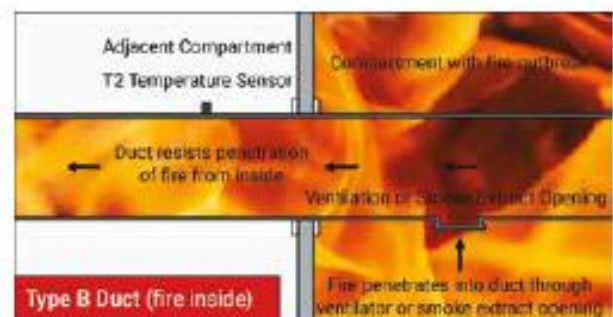
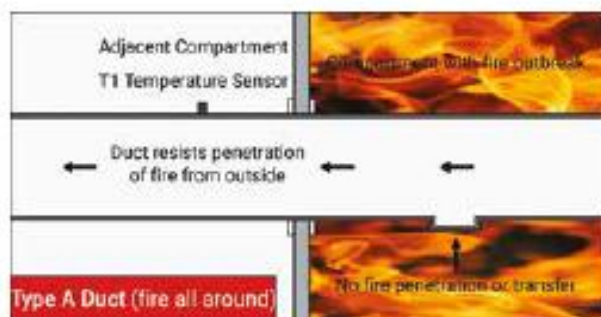



Description

Spiral Tube | Hotchkiss

Spirally Wound Tubing.

- Comes in a wide variety of diameters.
- Manufactured in standard 3.0m lengths.
- Custom lengths can be made upon request.
- Galvanised material - manufactured in accordance with DW144 specification.

Order Example:

SPT 150 3000

Product _____

Dimension $\varnothing d$ _____

Length _____

Also available in custom lengths.
Manufactured to order.

Dimensions

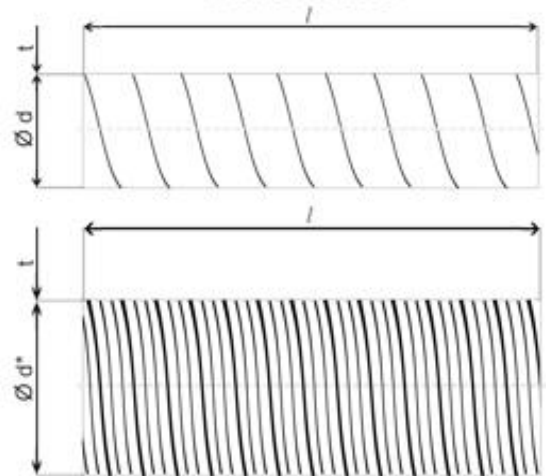

Nominal Diameter mm	Surface Area m ²	Cross Sectional Area m ²	Standard Gauge mm	Standard Length mm	Weight Kg/m
63	0.198	0.003	0.5	3000	1.01
80	0.251	0.005	0.5	3000	1.14
100	0.314	0.008	0.5	3000	1.42
112	0.352	0.010	0.5	3000	1.59
125	0.393	0.012	0.5	3000	1.78
140	0.440	0.015	0.5	3000	1.99
150	0.471	0.018	0.5	3000	2.13
160	0.503	0.02	0.5	3000	2.28
180	0.565	0.025	0.6	3000	3.07
200	0.628	0.031	0.6	3000	3.41
224	0.704	0.039	0.6	3000	3.82
250	0.785	0.049	0.6	3000	4.26
280	0.880	0.062	0.6	3000	4.78
300	0.942	0.071	0.6	3000	5.12
315	0.990	0.078	0.6	3000	5.38
355	1.115	0.099	0.8	3000	8.08
400	1.257	0.126	0.8	3000	9.10
450	1.414	0.159	0.8	3000	10.23
500	1.571	0.196	0.8	3000	11.37
560	1.759	0.246	0.8	3000	12.73
600	1.885	0.283	0.8	3000	13.65
630	1.979	0.312	0.8	3000	14.33
710	2.231	0.396	0.8	3000	16.15
800	2.513	0.503	0.8	3000	18.20
900	2.827	0.636	1.0	3000	25.58
1000	3.142	0.785	1.0	3000	28.43
1120	3.519	0.985	1.2	3000	38.21
1250	3.927	1.227	1.2	3000	42.64
1400	4.398	1.539	1.2	3000	47.76
1500	4.712	1.767	1.2	3000	51.17
1600	5.027	2.011	1.2	3000	54.58

Technical Data

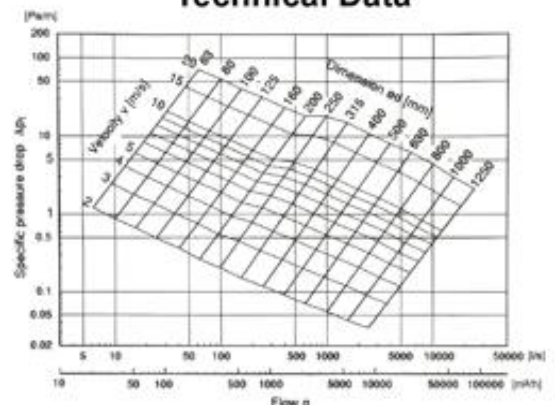

3.13 Proposed Elevations

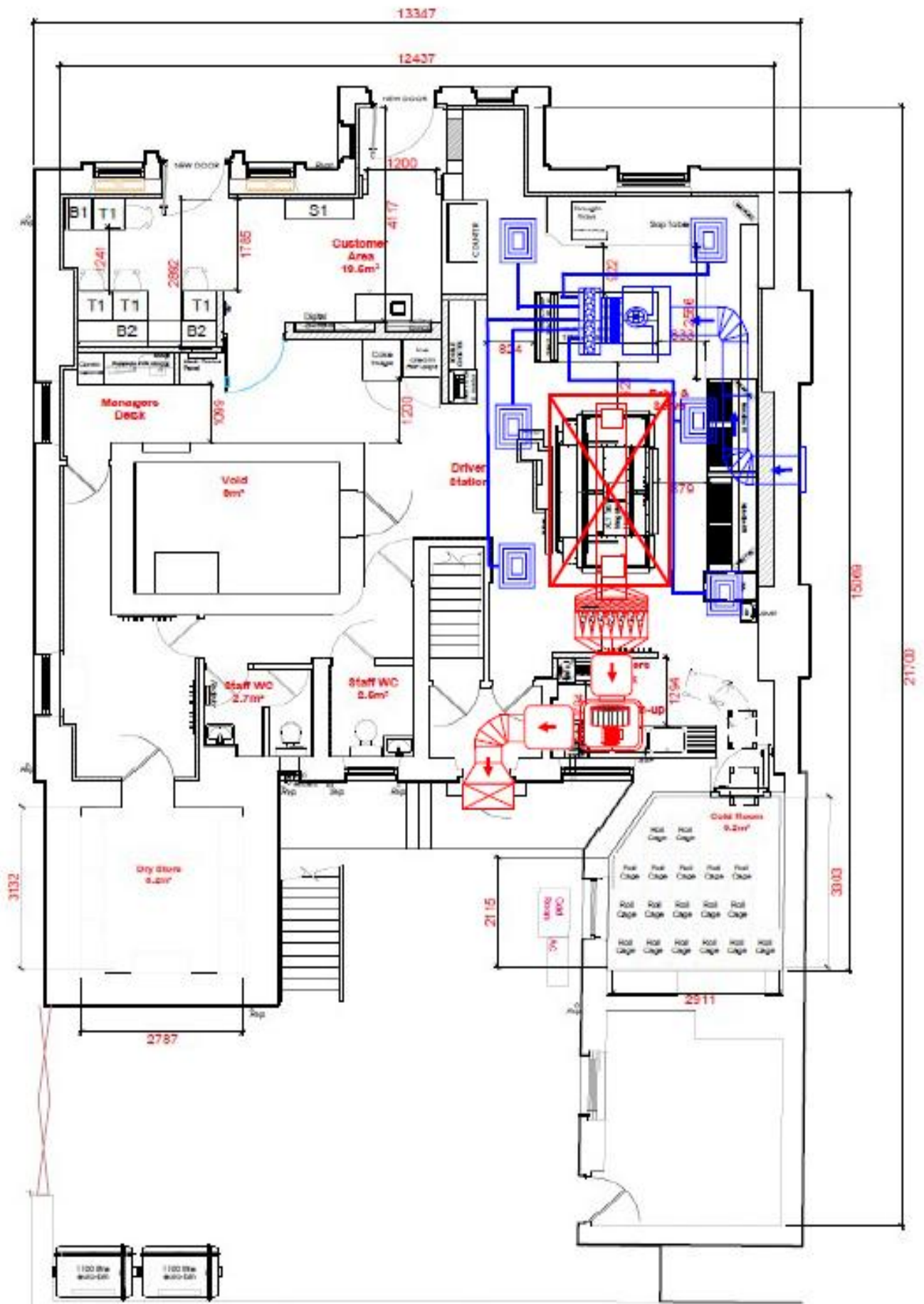



Fire rated ducting running up the outside of the building

03 - Existing Elevation 3

Scale 1 : 100

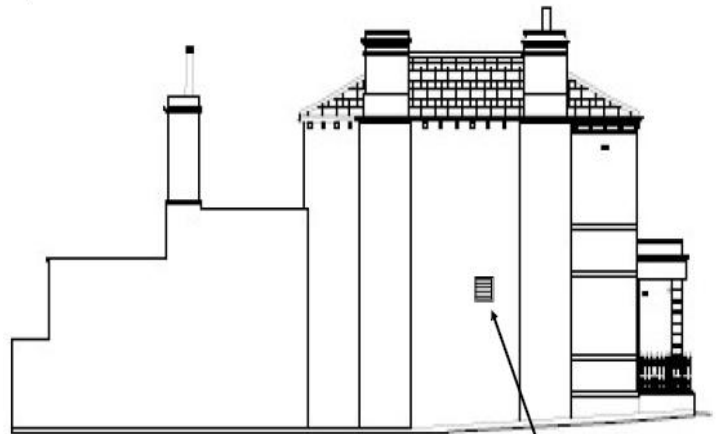

06 - Existing Elevation 6

Scale 1 : 100

500mm x 500mm weather louver grille



3.14 Odour Risk Assessment



Canopy UK - A guide to odour control

Odour control must be designed to prevent odour nuisance in each situation. The following diagram determines the odour control required using a risk assessment method. Please see below for considerations considered to calculate the level of odour control required.

Impact Risk	Odour control requirement	Significance score*
Low – medium	Low level odour control	Less Than 20
High	High level odour control	20-35
Very High	Very high-level odour control	35+

*Based on the sum of contributions from dispersion, proximity of receptors, size of kitchen & cooking type

Criteria	Score	Score	Details
Dispersion	Very Poor	20	Low level discharge, discharge into courtyard or restriction on stack.
	Poor	15	Not low level but below eaves, or discharge at below 10m/s
	Moderate	10	Discharging 1m above eaves at 10-15 m/s
	Good	5	Discharging 1m above the ridge at 15 m/s
Proximity of receptors	Close	10	Closest sensitive receptor less than 20m from kitchen discharge
	Medium	5	Closest sensitive receptor between 20 and 100m
	Far	1	Closest sensitive receptor more than 100m from kitchen discharge
Size of kitchen	Large	5	More than 100 covers or large size takeaway
	Medium	3	Between 30 and 100 covers or medium size takeaway
	Small	1	Less than 30 covers or a small takeaway
Cooking type (odour and grease loading)	Very high	10	High Level pub, fried chicken, burgers or fish & Chips
	High	7	Kebab, Vietnamese, Thai or Indian
	Medium	4	Cantonese, Japanese or Chinese
	Low	1	Most pubs, Italian, French, Pizza or steakhouse.

Example application of scoring procedure for four different cooking situations

Example	Dispersion	Proximity of receptors	Size of kitchen	Cooking type	Total score
1, Pub	15	1	5	1	22
2, Kebab	20	10	3	7	40
3, Medium Indian	15	5	5	7	32
4, French restaurant	5	10	1	1	17

Odour assessment of premises and surrounding areas.

Address

47 Huddersfield Road
Mirfield
WF14 8AE

- **Meals served per day** 100+
- **Cooking style.**
Pizza Oven
- **Meals served.**
Pizzas
- **Opening times.**
MON-SUN 11:00am – 10:00pm

Business	Dispersion	Proximity of receptors	Size of kitchen	Cooking type	Total score
Take away	5	10	3	1	19

With an impact risk of 19, this system will require a higher level of odour control, Canopy UK propose installing the following:

Fine filtration, with carbon bag filter. 0.4 second Dwell time will be achieved with the filter box sizing and filtration.

Assessed & Signed

John Ellingham

Canopy UK

23/03/25

Canopy UK, use Defra & DW/172 as a guidance for the calculations we carry out.

3.15 Gas inter-Lock System

Gas inter-lock

The Ventilation/Gas interlock system for the kitchen area shall be supplied by Canopy UK Direct Ltd Gas Safety Systems type Merlin CT1250.

The panel dimensions are 254mm high x 178mm wide x 62 mm deep. The box shall be rated to IP65 it shall be an ABS enclosure and be CE Approved. The fascia of the panel should be key operated (on/off) and a shrouded emergency shut off button located in the top right hand corner should be fitted (to meet BS6173.2001).The Ventilation/Gas interlock panel shall have a total of 7 L.E.D'S on the fascia, these should be: Power, Gas On, EM Stop, Supply Fan, Extract Fan, Fan Fault and Service).

1 x Merlin CT1250 Pan

1 x Gas Solenoid Valve (Size to be 1 1/4)

2 x Remote Gas Shut-Off Button (where required) to be fitted to the fire exists

This system work on using current monitoring instead of air flow switches.

MERLIN RANGE



KITCHEN EQUIPMENT

Merlin CT1250

The Merlin CT1250 ventilation interlock system, with built in current monitoring, is designed specifically for use in commercial kitchens to meet **BS6173: 2001**, which is now a much-recognised standard in the catering industry.

This panel is to be used when the kitchen appliances do have flame failure devices, therefore Gas proving is not a requirement.

The Merlin CT1250 acts as an interlock between the ventilation system and the gas solenoid valve. The system has a built in power monitor which is a method used for interlocking a kitchen's gas supply with the ventilation system. As an alternative to pressure differential switches the CT1250 is designed to monitor the electrical current going to a ventilation fan. When the fan is turned "on" the CT1250 monitors the electrical current going to the fan motor, when there is sufficient current going to the fan motor our panel receives a signal to indicate the fans are operating. Turning the key to the "on" position will open the gas solenoid valve. If the fans should fail, the "fan fault" LED on the panel will illuminate and the gas solenoid valve will close.

When there is a "fan fault" the supply fan or extract fan led on the Merlin CT1250 panel fascia will flash. This informs the electrician or kitchen staff which fan has failed.

Operating the system in the above manner will ensure the requirements of **BS6173: 2001** are fully met where all the catering equipment has flame failure devices fitted. Installation for the Merlin CT1250 is easy as there is no calibration. Wiring of the system is straightforward using volt free connections for all BMS and remote emergency stops. A corgi-registered installer would be required to fit the gas solenoid valve. All panels and gas solenoid valves supplied by S&S Northern carry a full 3-year manufactures warranty.

Current Monitoring

Calibration of the current monitor is easy, once wired set the fan speed controller to setting 1 (or low setting) for example.

Turn the blue rotary switches anti-clockwise until the green LED goes out, then slowly turn clockwise until the green LED is again illuminated. This will give you the minimum current requirement, if the fan is turned off the LED will go out, send a signal to the Merlin panel, which will in turn shut off the gas.

Key features of the Merlin CT1250

- Allows Compliance with BS6173: 2001 for commercial kitchens
- Clear LED display for system indications
- Complete all in one box
- Can be used when pressure differential switches cannot be used e.g. wall-mounted fans
- Reliable method of interlock, with no moving parts there's little to go wrong
- Straightforward to install and calibrate. The CT1250 can be easily adjusted to the users requirements
- This method is not recommended with belt driven fans
- Easy installation
- BMS Terminals Normally Closed or Normally open and common.
- Will accept remote emergency shut-off buttons
- Three year warranty
- All Merlin systems are designed to comply with the latest CE requirements and low voltage directives

4.0 Cold-rooms and Airconditioning Compressor date sheets

Cold room 10-15sqm

TYPICAL AIR CONDITIONING AND COLD ROOM COMPRESSOR DETAILS



FDUM125VNXWPVH

12.5 (3.5 ~ 14.0)

Indoor Unit : FDUM60VH x 2

Outdoor Unit : FDC125VNX-W

Specifications

R32

Indoor unit		FDUM60VH x 2			
Outdoor unit		FDC125VNX-W			
Power source		1 Phase 220-240V, 50Hz / 220V, 60Hz			
Nominal cooling capacity (Min-Max)		kW	12.5 (3.5 ~ 14.0)		
Nominal heating capacity (Min-Max)		kW	14.0 (2.7 ~ 17.0)		
Power Consumption	Cooling/Heating	kW	3.26 / 3.26		
EER/COP	Cooling/Heating	kW	3.83 / 4.30		
Inrush current		A	5		
Max. current		A	28		
Sound power level*1	Indoor*2	Cooling/Heating	dB(A)	60 / 60	
	Outdoor	Sound power level	dB(A)	68 / 70	
Sound pressure level*1	Indoor*2	Cooling (P-HI/Hi/Me/Lo)	dB(A)	36 / 31 / 28 / 25	
	Indoor	Heating (P-HI/Hi/Me/Lo)	dB(A)	36 / 31 / 28 / 25	
	Outdoor	Cooling/Heating	dB(A)	53 / 54	
Air flow	Indoor*2	Cooling (P-HI/Hi/Me/Lo)	m ³ /min	20 / 15 / 13 / 10	
	Indoor	Heating (P-HI/Hi/Me/Lo)	m ³ /min	20 / 15 / 13 / 10	
	Outdoor	Cooling/Heating	m ³ /min	100 / 100	
External static pressure*2		Pa	Standard:35 Max:100		
Exterior dimensions	Indoor	HeightxWidthxDepth	mm	280 x 950 x 635	
	Outdoor		mm	1,300 x 970 x 370	
Net weight		Indoor/Outdoor	kg	34 / 97	
Refrigerant Type GWP				R32/675	
Ref.piping size	Liquid/Gas	ømm	9.52(3/8") / 15.88(5/8")		
Refrigerant line (one way) length		m		Max.100	
Vertical height differences		Outdoor is higher/lower	m		Max.50 / Max.15
Outdoor operating temperature range	Cooling*2		°C		-15~50
	Heating		°C		-20~20
Air filter, Q'ty					(Option) Filter kit : UM-FL2EF
Remote control (option)					wired:RC-EX3A, RC-E5, RCH-E3 wireless:RCN-KIT4-E2

The data is measured under the following conditions(ISO-T1).

Cooling: Indoor temp. of 27°CDB, 19°CWB, and outdoor temp. of 35°CDB. Heating: Indoor temp. of 20°CDB, and outdoor temp. of 7°CDB, 6°CWB.

*1: Indicates the value in an anechoic chamber. During operation these values are somewhat higher due to ambient conditions

*2: If a cooling operation is conducted when the outdoor air temperature is -5°C or lower, the outdoor unit should be installed at a place where it is not influenced by natural wind, if wind blows, the low pressure will drop and compressor frequency will increase, this will cause the capacity to drop and may cause the unit to break down

*3: The values are for one indoor unit operation. (Multi system only) External static pressure is changeable to be set by the remote control. MAX external static pressure is 'High static pressure' setting. The values of sound pressure level become 5dB(A) higher at external static pressure of 100Pa.

Schematics

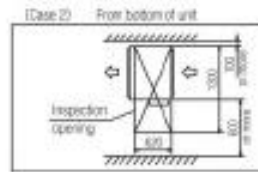
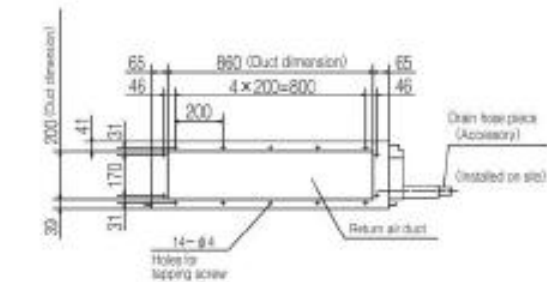

Symbol	Content
Model	60 71
A	Gas piping $\phi 12.7 (1/2")$ (Flare) $\phi 15.88 (5/8")$ (Flare)
B	Liquid piping $\phi 6.35 (1/4")$ (Flare) $\phi 9.52 (3/8")$ (Flare)
C1	Drain piping VP25 (O.D.32)
C2	Drain piping (Gravity drainage) VP60
D	Hole for wiring
F	Suspension bolts (3/8")
F	Outside air opening for ducting $\phi 152$ (Knock out)
G	Air outer opening for ducting $\phi 125$ (Knock out)
H	Inspection opening (320x62)

Note (1) The model name label is attached on the lid of the control box.

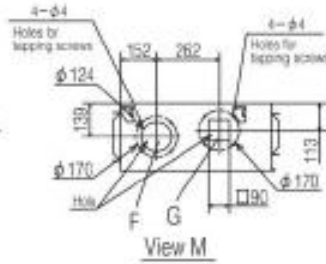
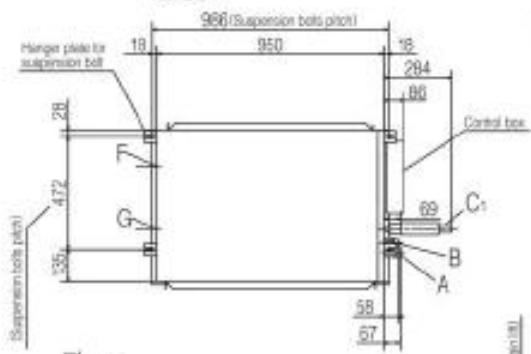

Space for installation and service

Select either of two cases to keep space for installation and services.
(Case 1) From side of unit

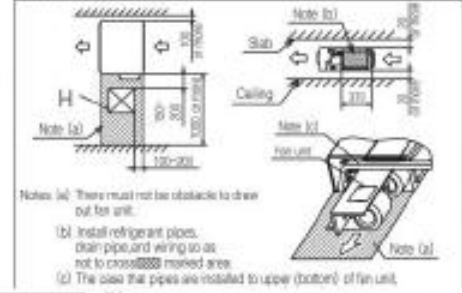

- Notes:
- (1) It must not be surrounded by walls on the four sides.
 - (2) The unit must be fixed with anchor bolts. An anchor bolt must not protrude more than 10mm.
 - (3) Where the unit is subject to strong winds, lay it in such a direction that the lower outlet faces perpendicularly to the dominant wind direction.
 - (4) Leave 1m or more space above the unit.
 - (5) A wall in front of the lower outlet must not exceed the unit height.
 - (6) The model name label is attached on the lower right corner of the front panel.

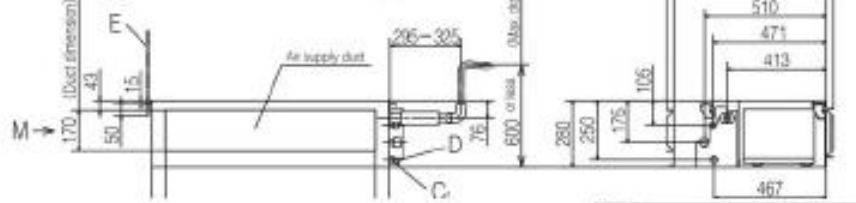

Symbol	Content
A	Service valve connector of the attached connecting pipe (Gas side) $\phi 15.88 (5/8")$ (Flare)
B	Service valve connector (Liquid side) $\phi 9.52 (3/8")$ (Flare)
C	Pipe/cable draw-out hole
D	Drain discharge hole $\phi 25$ (3places)
E	Anchor bolt hole M12 (4places)
F	Cable draw-out hole $\phi 30$ (3places)

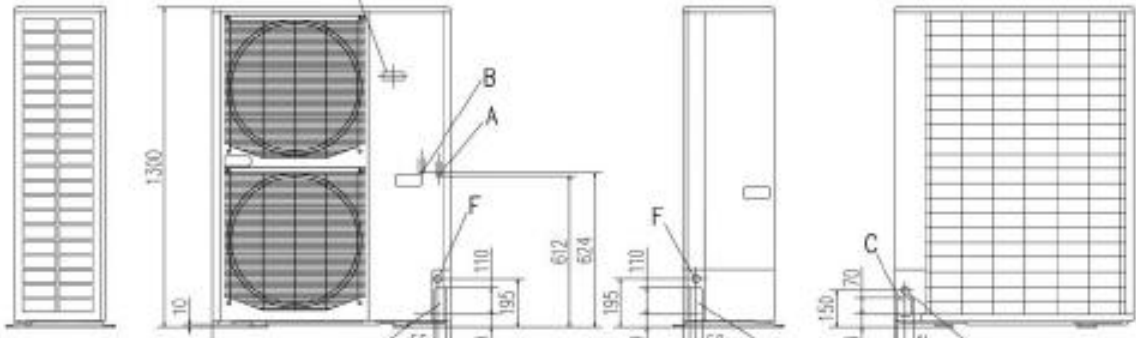
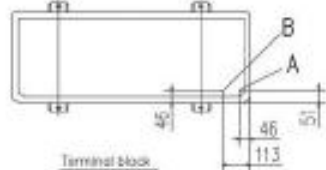

Category of Dimension	I	II	III
L1	Open	Open	500
L2	300	5	Open
L3	150	300	150
L4	5	5	5

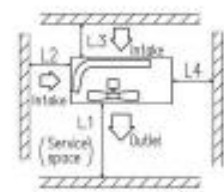
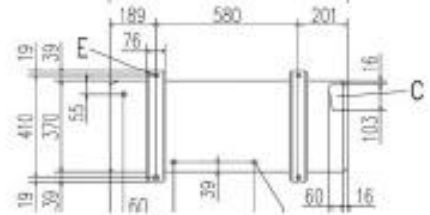



Condensing unit
Voltage Code : FZ

WINAJ4519Z-FZ

High Temp. Commercial (HP)

220 - 240V 1~ 50 Hz

R452A / R404A / R448A / R449A

WINAJ4519Z-FZ

Conditions	Frequency	Nominal Cooling Capacity		Sound Power ISO3745 / ISO 3743-1
		Watts	BTU/h	
EN13215 / R452A	50 Hz	2729	9306	63 dBA
EN13215 / R404A	50 Hz	2880	9754	63 dBA
EN13215 / R448A	50 Hz	2501	8528	63 dBA
EN13215 / R449A	50 Hz	2502	8532	63 dBA

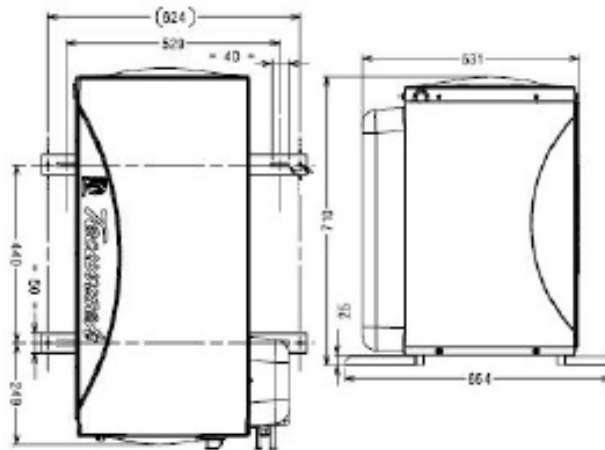
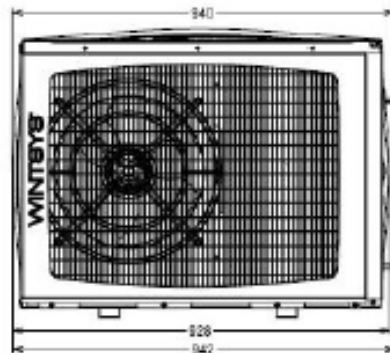

* EN13215 : T*Ambient 32.0°C / T*Evap. -10.0°C / T*Return gas temp.. 20.0°C
T*Subcooling. 3.0K

Net Weight (Kg)	65.0
Expansion device	Expansion_Valve
Air Flow (m³/h)	1650
Compo Data Sheet	224ST-FZ
Elec Comp Type	CSR
Current (Amp)	
Load Rated Amp	10,7
Max Cont Current	17,1
Lock Rotor Amp	48
Fan	
Speed (rpm)	546
Power (W)	56.0
Diameter (mm)	360
Protection	Overload
IP Level	IP44
Condenser	360/14100
Liquid Receiver	
Capacity (L)	2.35
Maximum Pressure (Bars)	32.0
Suction Line	
Suction Type	Tube / Tube
For Tubing Out Diam	15.9 (5/8")
Suction Connection Type	Brased
Liquid Line	
Liquid Line Type	Tube
For Tubing Out Diam	9.5 (3/8")
Liquid Connecton Type	Brased
Heat recovery pipes	
Component/ Type of connexion	NA
For tube Outside diameter :	NA

Note : Tecumseh reserves the right to change information contained in this document without notification.

maille < à 8mm



Tecumseh

WINAJ4519Z-FZ	Tension FZ : 220 - 240V 1~ 50 Hz
----------------------	---

Les performances sont données dans les conditions EN13215 :
Condition Dew

Gaz aspirés : 20.0 °C
Sous refroidissement : 3.0 K

The performance data are in EN13215 conditions :
Dew Condition

Return gas : 20.0 °C
Subcooling : 3.0 K

50 Hz R452A



N°6435

5 T ambiante	6 T évaporation	(°C)	-25	-20	-15	-10	-5	0	5	10	15
25	1 P frigorifique	(Watt)	1550	2006	2509	3060	3659	4306	5007	5773	6622
	2 P absorbée	(W)	1136	1259	1389	1528	1676	1836	2007	2189	2381
	3 I absorbée	(A)	5.25	5.75	6.31	6.93	7.61	8.36	9.18	10.1	11.0
	4 Tc	(°C)	29.6	31.3	33.2	35.3	37.5	39.7	41.9	43.9	45.8
32	1 P frigorifique	(Watt)		1763	2228	2729	3266	3843	4467	5153	5921
	2 P absorbée	(W)		1289	1432	1584	1746	1920	2104	2299	2502
	3 I absorbée	(A)		5.81	6.44	7.14	7.89	8.71	9.59	10.5	11.5
	4 Tc	(°C)		37.2	39.2	41.2	43.3	45.5	47.5	49.4	51.0
43	1 P frigorifique	(Watt)			1775	2194	2634	3100	3605	4168	4817
	2 P absorbée	(W)			1474	1653	1842	2042	2252	2471	2696
	3 I absorbée	(A)			6.60	7.42	8.29	9.22	10.2	11.2	12.3
	4 Tc	(°C)			48.6	50.6	52.6	54.6	56.4	58.1	59.4

50 Hz R404A

N°6377

5 T ambiante	6 T évaporation	(°C)	-25	-20	-15	-10	-5	0	5	10	15
25	1 P frigorifique	(Watt)	1685	2149	2657	3208	3801	4435	5116	5852	6662
	2 P absorbée	(W)	1198	1323	1453	1592	1739	1896	2063	2239	2423
	3 I absorbée	(A)	5.55	6.05	6.61	7.22	7.90	8.64	9.44	10.3	11.2
	4 Tc	(°C)	32.4	34.1	36.0	38.1	40.2	42.4	44.5	46.4	48.2
32	1 P frigorifique	(Watt)		1893	2362	2860	3389	3950	4550	5202	5927
	2 P absorbée	(W)		1359	1503	1654	1815	1984	2163	2350	2544
	3 I absorbée	(A)		6.13	6.77	7.46	8.20	9.01	9.87	10.8	11.7
	4 Tc	(°C)		40.0	41.8	43.8	45.9	47.9	49.8	51.6	53.2
43	1 P frigorifique	(Watt)			1887	2301	2726	3174	3649	4172	4770
	2 P absorbée	(W)			1558	1735	1921	2115	2318	2528	2741
	3 I absorbée	(A)			6.97	7.78	8.64	9.55	10.5	11.5	12.5
	4 Tc	(°C)			50.9	52.8	54.7	56.6	58.3	59.8	61.1

1 = cooling capacity 2 = power input 3 = current 4 = condensing temperature 5 = ambient temperature 6 = evaporating temperature

Nota : Tecumseh se réserve le droit de modifier les informations contenues dans ce document sans préavis.

Note : Tecumseh reserves the right to change information contained in this document without notification.



WINAJ4519Z-FZ	Tension FZ : 220 - 240V 1~ 50 Hz
----------------------	----------------------------------

Les performances sont données dans les conditions EN13215 : Condition Dew	Gaz aspirés : 20.0 °C Sous refroidissement : 3.0 K
The performance data are in EN13215 conditions : Dew Condition	Return gas : 20.0 °C Subcooling : 3.0 K

50 Hz R448A (*)

N°7013

5 T ambiante	6 T évaporation	(°C)	-25	-20	-15	-10	-5	0	5	10	15
25	1 P frigorifique	(Watt)	1314	1756	2248	2793	3394	4057	4788	5600	6511
	2 P absorbée	(W)	1074	1190	1316	1452	1600	1760	1932	2115	2307
	3 I absorbée	(A)	4.94	5.42	5.96	6.57	7.26	8.01	8.83	9.71	10.6
	4 Tc	(°C)	29.9	31.6	33.6	35.7	37.9	40.2	42.4	44.4	46.3
32	1 P frigorifique	(Watt)		1540	1999	2501	3050	3653	4319	5063	5904
	2 P absorbée	(W)		1220	1360	1510	1673	1848	2035	2233	2439
	3 I absorbée	(A)		5.49	6.11	6.79	7.55	8.38	9.27	10.2	11.2
	4 Tc	(°C)		37.7	39.6	41.7	43.8	45.9	48.0	49.9	51.5
43	1 P frigorifique	(Watt)				2040	2507	3017	3581		
	2 P absorbée	(W)				1580	1772	1978	2195		
	3 I absorbée	(A)				7.09	7.97	8.92	9.93		
	4 Tc	(°C)				51.1	53.1	55.1	56.9		

50 Hz R449A (*)

N°6407

5 T ambiante	6 T évaporation	(°C)	-25	-20	-15	-10	-5	0	5	10	15
25	1 P frigorifique	(Watt)	1315	1757	2249	2794	3396	4059	4791	5604	6515
	2 P absorbée	(W)	1074	1190	1316	1452	1600	1760	1932	2115	2307
	3 I absorbée	(A)	4.94	5.42	5.96	6.57	7.26	8.01	8.83	9.71	10.6
	4 Tc	(°C)	29.9	31.7	33.6	35.7	37.9	40.2	42.3	44.4	46.2
32	1 P frigorifique	(Watt)		1541	2000	2502	3052	3655	4321	5065	5907
	2 P absorbée	(W)		1220	1360	1510	1673	1848	2035	2233	2439
	3 I absorbée	(A)		5.49	6.11	6.79	7.55	8.38	9.27	10.2	11.2
	4 Tc	(°C)		37.7	39.6	41.7	43.8	45.9	47.9	49.8	51.5
43	1 P frigorifique	(Watt)				2041	2509	3018	3582		
	2 P absorbée	(W)				1580	1772	1978	2195		
	3 I absorbée	(A)				7.09	7.97	8.92	9.93		
	4 Tc	(°C)				51.1	53.0	55.0	56.8		

1 = cooling capacity 2 = power input 3 = current 4 = condensing temperature 5 = ambient temperature 6 = evaporating temperature

(*) Veuillez vous référer abondamment aux recommandations d'utilisation et Bulletin Marketing Tecumseh du fait de la température de reboulement élevée pour les applications LDP.

(*) Due to very high discharge temperature especially on LDP conditions, please strictly refer to Tecumseh Guidelines & Marketing Bulletin when using this refrigerant.

Nota : Tecumseh se réserve le droit de modifier les informations contenues dans ce document sans préavis.

Note : Tecumseh reserves the right to change information contained in this document without notification.

© 2025 Tecumseh Products Company
All rights reserved

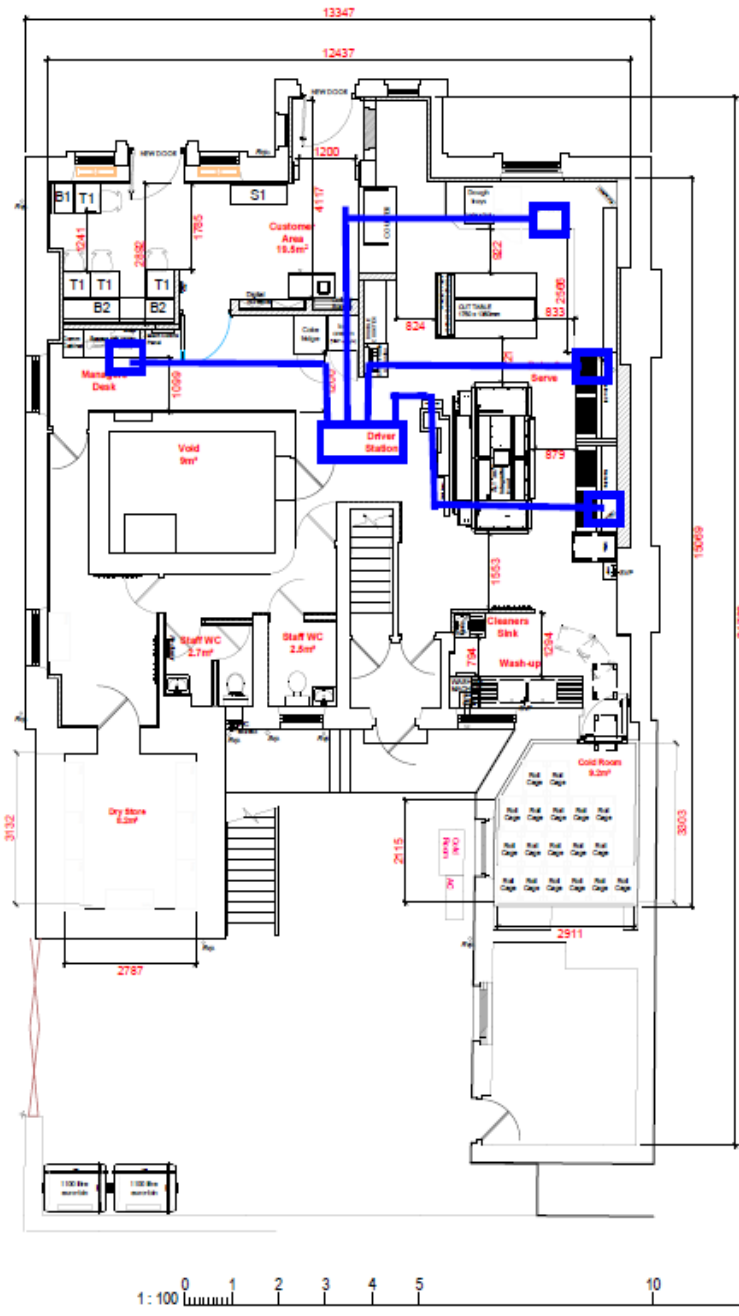

GAS CUPBOARD - Proposed location TBC

ELECTRIC CUPBOARD - existing location-basement. Relocation TBC.

CONDENSERS - to be consider on the back of the property in rear yard. Sizes TBC.

EURO BINS - to be consider on the back of the property.

EXTRACT DUCT - Location TBC
FRESH AIR INTAKE - Location TBC.

NOTES
 - Do not scale from this drawing, except for planning purposes
 - Check all dimensions on site.
 - Subject to survey.
 - Subject to site inspection.
 - Site boundary lines are indicative only.



NOTE:

GA: 148m²
(1593ft²)

All Works must comply with appropriate building regulations, and in particular Part M access to and use of buildings and Part K Protection from falling, collision and impact.

All proposed wall removals are subject to confirmation and approval by a structural engineer.

NO	DATE	BY	DESCRIPTION
01	24/01/25	HCH	Changes agreed on site meeting
02	07/01/2025	HCH	Final Issue

Revision Schedule



Project
 Domino's Mirfield
 47 Huddersfield Road
 Mirfield, WF14 8AE

Title
 Feasibility Layout

Working Status	Preliminary
Contract No.	-
Scale	1:100 @ A3
Client Ref.	-
Date	07/01/2025
Drawn by	HCH
Checked by	-

Working Number
 10131-SD-00-00-DR-A-SK001



Simons Design Ltd
 47 Oldfields
 Huddersfield, The Park, Huddersfield, Greater Manchester, WF14 8AE
 T: 01484 500 210
 E: info@simonsdesign.co.uk
 www.simonsdesign.co.uk

 For any more advice or support before placing the order please feel free to contact me
 07876 500 438 / 01733 7004

