



DRAINAGE IMPACT ASSESSMENT

Donaldson's Vets Honley

Reference	6369-JPG-XX-XX-RP-D-0621-S2-P03
Date	May 2024
Author	SMS

5 John Charles Way
LEEDS
LS12 6QA

Tel: 0113 263 1155
admin@jpg.group
www.jpg.group





CONTENTS

Confidentiality Statement

Document History

1.0	Introduction	1
2.0	The Site	1
3.0	Existing Drainage and Sewer Network	1
4.0	Development Proposals	1
5.0	Drainage Assessment	2
5.1	Proposed Surface Water Drainage & Disposal Hierarchy	2
5.2	Sustainable Urban Drainage Systems (SUDS)	3
5.3	Surface Water Drainage	3
5.4	Climate Change Allowance	4
5.5	Pollution Control	5
5.6	Foul Water Drainage	5
6.0	Conclusion	5

APPENDICES

Appendix A Site Location Plan

Appendix B Topographic Survey

Appendix C Yorkshire Water Records and Advice

Appendix D Historical Topographic Survey

Appendix E Architectural Layout

Appendix F LLFA Guidance

Appendix G Root Protection Area Plan

Appendix H Surface Water Strategy

Appendix J Surface Water Network Attenuation & Hydraulic Model Calculations

Appendix K Impermeable Area Plan

Appendix L SuDs Manual – SuDs Mitigation Indices

Appendix M Foul Water Strategy

Appendix N Overland Flow Plan



CONFIDENTIALITY STATEMENT

This report is addressed to and may be relied upon by the following:

Donaldson's Properties
131 Somerset Road
Almondbury
HUDDERSFIELD
HD5 8HN

This report has been prepared for the sole use and reliance of the above-named parties. This report shall not be relied upon or transferred to any other parties without the express written authorisation of JPG (Leeds) Limited. No responsibility will be accepted where this report is used, either in its entirety or in part, by any other party.

DOCUMENT HISTORY

Revision	Date	Revision Details	Status	Author(s)	Approved
P01	31.05.2024	First Issue	Information	SMS	BT
P02	13.09.2024	Drainage Strategy Amended	Information	SMS	BT
P03	29.04.2025	Drainage Strategy Amended	Information	LSG	RMR



1.0 INTRODUCTION

JPG (Leeds) Limited (JPG) has been instructed by Donaldson's Properties to prepare a Drainage Impact Assessment for a proposed veterinary clinic located off Woodhead Road, Honley. This report will review the impact of the drainage on the proposed development.

2.0 THE SITE

The site is located approximately 0.5 km to the east of Honley centre, adjacent to Woodhead Road and the River Holme. The approximate centre of the site is at National Grid Reference (NGR) 414193, 411805. A site location plan and aerial photograph are provided in Appendix A.

The site is irregularly shaped and covers an area of approximately 0.51 hectares (Ha). It is situated on a brownfield site, which was previously used as an industrial garage and yard.

The surrounding area is predominantly residential, with dwellings to the north and dense vegetation to the south of the site boundary. The eastern boundary lies along the bank of the River Holme, while the western boundary is adjacent to Woodhead Road.

The topography of the site generally slopes steeply from south to north. A copy of the topographic survey is provided in Appendix B.

3.0 EXISTING DRAINAGE AND SEWER NETWORK

We have received a consultation response Yorkshire Water, they have confirmed that there is a 225mm diameter combined sewer within Woodhead Road, located on the western boundary of the site. Following a site walkover and historical planning application information, it can be assumed that surface and foul water previously discharged into this sewer network, due to the locations of manhole and the absence of an outfall headwall/ pipe into the River Holme.

The Yorkshire Water sewer records and preplanning advise are located in Appendix C.

A copy of the historical topographical survey is located in Appendix D.

4.0 DEVELOPMENT PROPOSALS

The proposed development consists of veterinary clinic with an accompanying carpark. A drawing showing the proposed scheme is included in Appendix E. The drainage will be split into a surface water network and a foul water network.



5.0 DRAINAGE ASSESSMENT

5.1 Proposed Surface Water Drainage & Disposal Hierarchy

SuDS features employed as part of the drainage infrastructure on the development will be privately maintained by a private management company.

The detailed design and maintenance of SuDS features is outside the scope of this report.

The following assessment summarises the disposal of surface water from the site.

As detailed in Building regulation Document H the hierarchy for surface water drainage disposal is as follows:

- Discharge to ground (infiltration).
- Discharge to a surface water body (Land drainage Ditch, Water Body or Watercourse).
- Discharge to a surface water sewer.
- Discharge to a combined water sewer.
- Discharge to a foul water sewer.

All options for the disposal of the surface water have been considered in accordance with current legislation, recommendation, and good practice. Refer to Section 5.3 for more details.



5.2 Sustainable Urban Drainage Systems (SUDS)

The LLFA, Kirklees Council, has been previously contacted regarding the utilisation of SuDS features as part of the development.

The following audit has been carried out relating to suitability of SuDS features/systems:

Drainage Method	Description/Suitability	Proposal/Feasibility
1. Infiltration.	Site ground conditions assumed unsuitable for infiltration	Not Applicable
2. Ponds and wetlands.	May be utilised – subject to detailed design.	Applicable (non-infiltration method)
3. Infiltration Basins.	Site ground conditions assumed unsuitable for infiltration	Not Applicable
4. Detention Basins.	May be utilised – subject to detailed design.	Applicable (non-infiltration method)
5. Swale.	May be utilised – subject to detailed design.	Applicable (non-infiltration method)
6. French/Filter drain.	May be utilised to convey water.	Applicable (non-infiltration method)
7. Pervious/Permeable Pavement.	May be utilised - subject to detailed design.	Applicable (non-infiltration method)
8. Geocellular Systems/Tank systems.	May be utilised – subject to detailed design.	Applicable.
9. Oversized pipes.	May be used as surface water attenuation.	Applicable.
10. Box culverts.	May be used as surface water attenuation.	Applicable.
11. Proprietary tanks systems.	May be used as surface water attenuation.	Applicable.

Sustainable Urban Drainage System (SuDS) may be used in conjunction with conventional drainage systems to improve water quality as well as manage surface water discharge. This should be considered at the detailed design stage of the project.

5.3 Surface Water Drainage

Requirement H3 of the Building Regulations establishes a preferred hierarchy for the disposal of surface water. Consideration should firstly be given to soakaway, infiltration, watercourse, and sewer in that priority order.

The advice from the LLFA states that infiltration is not possible due to the site being close to the watercourse and being in British Geological Survey Zone 4.

A copy of the LLFA feedback and advice can be found in Appendix F.

Based on the above statement and drainage hierarchy connection to watercourse should be considered next.

The site benefits from the River Holme on the eastern boundary of the site and is the obvious point for surface water discharge. As per the advice received from the LLFA, surface water discharge to the River Holme should be restricted to 3l/s.



However, due to an existing Root Protection Zone located on the eastern boundary of the site, excavation within this area would not be feasible at the time of writing this report, subject to advice from the Local Planning Authority (Kirklees Council) regarding excavation works within the protected area. Therefore, the proposed network is to be directed towards the existing sewer network within Woodhead Road. The only available network to connect to is the existing 225mm combined sewer. JPG are yet to receive an agreed discharge rate into the combined sewer network; therefore, a discharge of 3l/s has been maintained.

The location of the Root Protection Area is indicated in Appendix G.

Surface water run off includes car parks and roof water drainage, this will be attenuated on site via twin 900 diameter concrete pipes situated beneath the western carpark. Carpark areas are to pass through a bypass separator before out falling into the attenuation pipes. A flow control device will restrict the discharge rate of the site to runoff rates of 3l/s. The surface water network will ultimately outfall via a new constructed manhole at the respective restricted discharge rate into existing combined network.

The surface water drainage strategy has been provided in Appendix H.

The surface water drainage network will drain a total impermeable area of 0.255Ha, attenuation is to be provided via oversized pipes with a volume of 120.000m³ and a restricted discharge of 3.0l/s into the existing combined Yorkshire Water sewer.

Please refer to Appendix J for the surface water hydraulic network model including the surface water attenuation calculation.

The Impermeable Area Plan has been included within Appendix K.

5.4 Climate Change Allowance

For new developments, the current design criteria required for the surface water drainage will need to be based upon a 1 in 100-year storm event, with an additional allowance for climate change resulting from global warming.

Proposed allowance for climate change for this development is 45% based on latest Environment Agency Climate Change Allowances.

The proposed drainage strategy drawing is in Appendix H and detailed network calculations are locating Appendix J.

The proposed onsite drainage system shall be designed in accordance with the requirements of Sewers for Adoption and shall demonstrate that:

- No surcharge of pipes occurs in the 1 in 1-year rainfall event.
- No surface flooding occurs in 1 in 30-year rainfall event.
- No flooding to buildings and adjacent properties occurs in 1 in 100-year rainfall event (including an allowance of 45% for the effects of future climate change), as defined in NPPF Technical Guidance.



SuDS features will be incorporated into the design where practical to do so.

5.5 Pollution Control

It is a requirement to ensure that the quality of any receiving water body is not adversely affected by the development.

To minimise the risk of pollution to the final discharge point, clean roof water drainage should discharge directly into the sealed drainage network (i.e., not via gullies).

Impermeable areas which are to be used for vehicle parking and circulation will be finished in concrete and would provide little or no treatment. Therefore, an appropriately sized, and specified oil interceptor will be installed to provide treatment for these areas.

Pollution mitigation (total suspended solids, metals, and hydrocarbons) and the improvement of water quality have been accounted for through the implementation of filter drains and proprietary treatment systems in the form of petrol interceptors. SuDS mitigation indices for the proposed treatment components are provided in Appendix L, the quoted indices are in line with Table 26.3 of the SuDS manual and the manufacturers specification.

5.6 Foul Water Drainage

Following consultation with Yorkshire Water, JPG have received existing sewer network plans and advise. Following the advice, the combined sewer network located within Woodhead Road would be the obvious discharge location for foul water.

JPG have proposed a new manhole is to be constructed within the existing network and serve as a discharge point for both the foul and surface water. The foul water network is to outfall into this manhole via a 150mm diameter pipe.

Refer to Appendix M for the Foul Water Drainage Strategy.

6.0 CONCLUSION

The report has been prepared to assess the drainage impact for a proposed veterinary clinic off Woodhead Road, Honley.

The onsite private surface water drainage system will be designed and constructed in accordance with Building Regulations, all national and local standards and best practice.

Hierarchy for discharge of surface water has been considered as detailed in building regulations document H3. Consideration should firstly be given to soakaway, infiltration, watercourse, and sewer in that priority order.



The site benefits from the River Holme watercourse traversing adjacent to the eastern site boundary. However, due to a Root Protection Area, surface water run off drainage will be restricted by flow control devices and attenuated on plot before discharging via a restricted rate into an existing Yorkshire Water combined sewer.

JPG have received advice from Yorkshire Water along with sewer record plans. The obvious drainage route for foul water is to be discharged into the existing combined water drainage sewer located within Woodhead Road via a 150mm diameter pipe connection.

It is assumed that the external consultees will agree with the proposed approach, however, should these consultees respond after this report is submitted for planning and require different criteria the Drainage Impact Assessment Report and drainage strategy will need to be reviewed to take into consideration any comments received.



Appendix A Site Location Plan



SITE LOCATION PLAN
SCALE 1:1250

DO NOT SCALE (A1)

NOTES

GENERAL NOTES

1. ALL MATERIALS AND WORKMANSHIP IS TO COMPLY WITH JPG CONSULTANTS STANDARD SPECIFICATION & ALL RELEVANT BRITISH & EUROPEAN STANDARDS.
2. THIS DRAWING IS TO BE READ IN CONJUNCTION WITH ALL RELEVANT ARCHITECTS, M & E CONSULTANTS AND JPG CONSULTANTS DRAWINGS.
3. ANY DISCREPANCIES SHOULD BE REPORTED TO THE ENGINEER IMMEDIATELY SO THAT CLARIFICATION CAN BE SOUGHT PRIOR TO COMMENCEMENT OF WORKS.

APPROXIMATE CO-ORDINATES

ORDINANCE SURVEY
EASTINGS 414193, NORTHINGS 411805
NATIONAL GRID
SE141118/SE1419311805



REV	DESCRIPTION	DATE	CHK	BY
P01	ISSUED FOR INFORMATION	28.05.24	RMR	SMS

Project
DONALDSON'S VETS
HONLEY

Drawing Title
SITE LOCATION PLAN

INFORMATION





Appendix B Topographic Survey



Appendix C Yorkshire Water Records and Advice



YorkshireWater

JPG (Leeds) Limited
5 John Charles Way
Leeds
West Yorkshire
LS12 6QA
sam.smickersgill@jpg.group

Yorkshire Water Services
Developer Services
Pre-Development Team
PO BOX 52
Bradford
BD3 7AY

Tel: 0345 120 8482

Fax:

Email:

technical.sewerage@yorkshirewater.co.uk

Your Ref:
Our Ref: A002668

For telephone enquiries ring:
George Mullaney on 0345 120 8482

13th June 2024

Dear Mr Smickersgill,

Woodhead Road, Honley, HD9 6NR – Pre-planning Enquiry V515366

Thank you for your recent enquiry. Our charge of £187.00 plus VAT will be added to your account with us, reference JPG027. You will receive an invoice for your account in due course.

Please find enclosed a complimentary extract from the Statutory Sewer Map which indicates the recorded position of the public sewers. Please note that as of October 2011 and the private to public sewer transfer, there are many uncharted Yorkshire Water assets currently not shown on our records. The following comments reflect our view, with regard to the public sewer network only, based on a 'desk top' study of the site and are valid for a maximum period of twelve months:

Foul Water

Development of the site should take place with separate systems for foul and surface water drainage. The separate systems should extend to the points of discharge to be agreed.

Foul water domestic waste can discharge to the 225 mm diameter public combined sewer recorded in Woodhead Road, at a point west of the site.



Surface Water

The developer's attention is drawn to Requirement H3 of the Building Regulations 2010. This establishes a preferred hierarchy for surface water disposal. Consideration should firstly be given to discharge to soakaway, infiltration system and watercourse in that priority order.

Sustainable Drainage Systems (SuDS), for example the use of soakaways and/or permeable hardstanding etc, may be a suitable solution for surface water disposal appropriate in this situation. You are advised to seek comments on the suitability of SuDS in this instance from the appropriate authorities.

It is understood that a watercourse (River Holme) is located to the east of the site. This appears to be the obvious place for surface water disposal (if SuDS are not viable).

Yorkshire Water has no objection in principle to :

- 1) The separate systems on and off site.
- 2) The point of discharge for surface water to watercourse.

Submitted on drawing numbered 6369-JPG-ZZ-ZZ-DR-D-1400 (revision P01), dated 28/05/2024 that has been prepared by JPG Group.

Please note further restrictions on surface water disposal from the site may be imposed by other parties. You are strongly advised to seek advice/comments from the Environment Agency/Land Drainage Authority/Internal Drainage Board, with regard to surface water disposal from the site.

Other Observations

Any new connection to an existing public sewer will require the prior approval of Yorkshire Water. You may apply online or obtain an application form from our website (www.yorkshirewater.com/developers/sewerage/sewerage-connections/) or by telephoning 0345 120 84 82.

Under the provisions of section 111 of the Water Industry Act 1991 it is unlawful to pass into any public sewer (or into any drain or private sewer communicating with the public sewer network) any items likely to cause damage to the public sewer network or interfere with the free flow of its contents or affect the treatment and disposal of its contents. Amongst other things this includes fat, oil, nappies, bandages, syringes, medicines, sanitary towels and incontinence pants. Contravention of the provisions of section 111 is a criminal offence.

An off-site foul and surface water sewer may be required which may be provided by the developer and considered for Code for Adoption under Section 104 of the Water Industry Act 1991. Please telephone 0345 120 84 82 for advice on sewer adoptions. Alternatively, the developer may in certain circumstances be able to requisition off-site sewers under



YorkshireWater

Section 98 of the Water Industry Act 1991 for which an application must be made in writing. For further information, please telephone 0345 120 84 82.

Prospectively adoptable sewers and pumping stations must be designed and constructed in accordance with the Code for Adoption, pursuant to an agreement under Section 104 of the Water Industry Act 1991. We are happy to offer pre-development technical advice on any prospective sites that you would like to put forward for adoption, prior to submission of your adoption application.

An application to enter into a Section 104 agreement must be made in writing prior to any works commencing on site. Please contact our Sewer Adoption, Diversion and Requisition (telephone 0345 120 84 82) or email technical.sewerage@yorkshirewater.co.uk or visit - <https://www.yorkshirewater.com/developers/sewerage/sewer-adoptions/> for further information.

The site is within an area that may be affected by river, coastal or estuarine flooding. We would advise you to contact the Environment Agency for details.

All the above comments are based upon the information and records available at the present time and are valid for a period of 12 months. The information contained in this letter together with that shown on any extract from the Statutory Sewer Map that may be enclosed is believed to be correct and is supplied in good faith. Please note that capacity in the public sewer network is not reserved for specific future development. It is used up on a 'first come, first served' basis. You should visit the site and establish the line and level of any public sewers affecting your proposals before the commencement of any design work.

Yours sincerely

George Mullaney
Development Control Technician

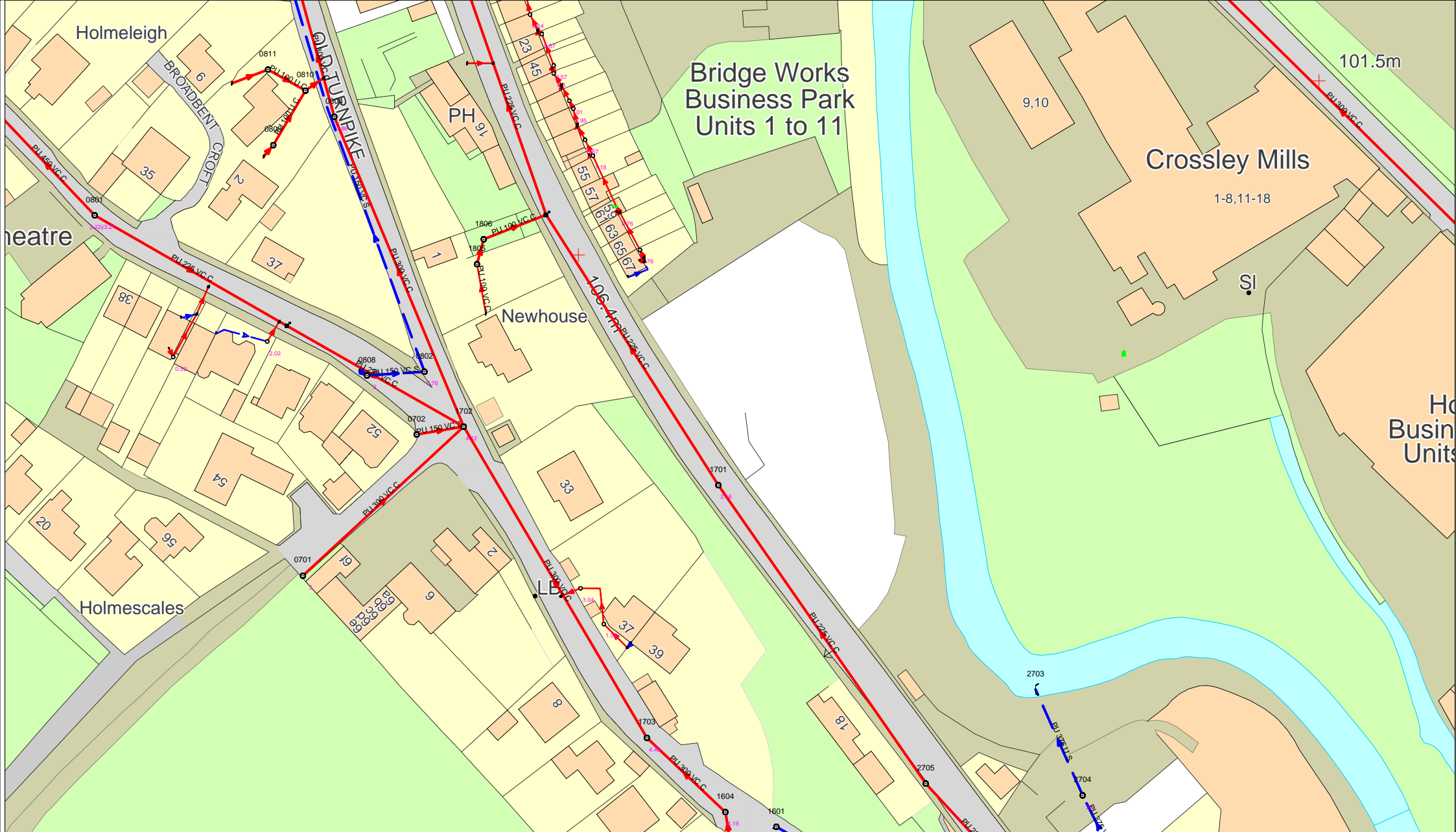

414003 : 411701	Map Name : SE1311NE	Title	Partial Key	This plan is furnished as a general guide only and no warranty as to its correctness is given or implied. This plan must not be relied upon in the event of excavations or other works made in the vicinity of public sewers. No house or property connections are shown.
	Yorkshire Water, PO Box 500, Halifax Road, Bradford BD6 2LZ Contact Name : G Mullaney Contact Tel :	Notes (Ody) COPYRIGHT STATEMENTS: Reproduced by permission of Ordnance Survey on behalf of HMSO © Crown copyright and database 2014. All rights reserved Ordnance Survey Licence number 100022432	Foul Sewer = F Combined Sewer = C Surface Water Sewer = SW Trade Sewer = TD Partially Separate = PS Date Req : 13/06/2024, 12:31:59 Source : Sewer Network Enquiry	Date Gen : 13/06/2024, 12:32:22



Appendix D Historical Topographical Survey

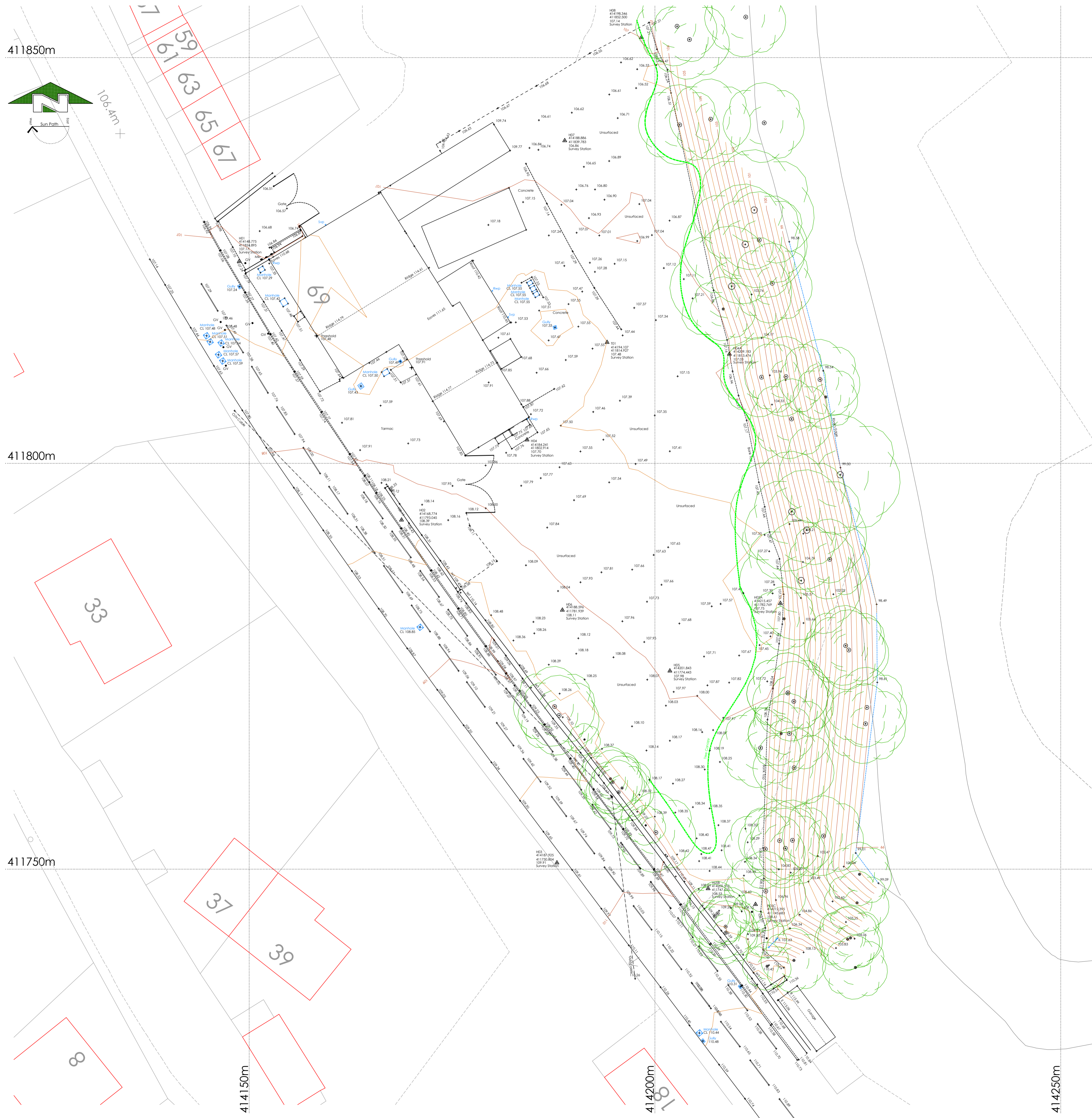

Location Plan Scale 1:1000

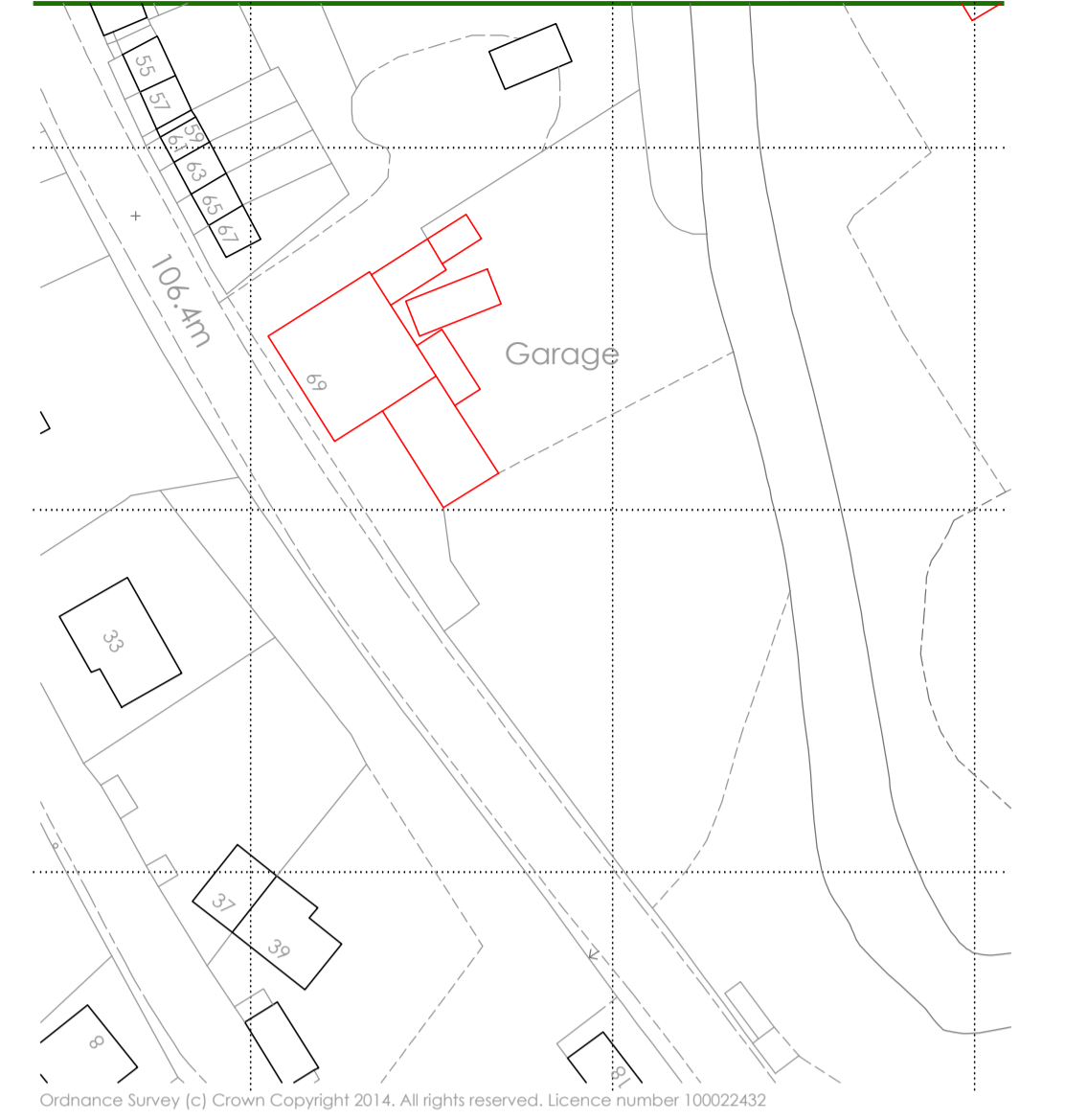

Reference	Survey Control Co-ordinates		Description
	East	North	
HS1	414148.775	411824.895	107.17 Survey Station
HS2	414148.774	411793.045	108.39 Survey Station
HS3	414187.925	411750.804	109.31 Survey Station
HS4	414184.241	411802.914	107.70 Survey Station
HS4A	414209.183	411813.474	107.03 Survey Station
HS5	414201.343	411744.443	107.98 Survey Station
HS6A	414214.437	411782.727	107.25 Survey Station
HS6B	414206.352	411747.223	108.33 Survey Station
HS6C	414212.395	411745.283	108.61 Survey Station
HS6	414188.396	411781.939	108.11 Survey Station
HS7	414188.886	411839.783	105.86 Survey Station
HS8	414198.346	411852.500	107.14 Survey Station

Control & Datum Information
Grid Orientation:
 Survey related to Ordnance Survey "OSGB36" at control point GPS01
 realtime correction received via Leica Geosystems "Smart Net" service.
Level Datum:
 OS Orthometric hts

Rev	Description	By	Date

Surv.	Drawn	Date	Chkd	Date
NH	NH	03.03.14		

This drawing may not be reproduced, made use of or issued to a third party without permission of:
David Storie Associates

David Storie Associates
 Town Planning Consultants
 Wellington House
 Lincoln Street
 Huddersfield
 HD1 6RX

Holden Surveys Ltd
 Topographical Building & Site Surveys - CAD Services
 T/F: 01226 755365 E: holdensurveys@msn.com

Title. Site Plan
Site. Woodhead Road
 Honley
 Huddersfield

COMPUTER GENERATED DRAWING - DO NOT ALTER
Dwg No. DSA_01_Riverside Wks
Sheet No. 1

SCALE	1/250	REV.



Appendix E Architectural Layout



DO NOT SCALE FROM THIS DRAWING

Notes
 All dimensions to be checked on site
 Any discrepancies to be reported immediately to the Architect
 Drawing to be read in conjunction with all relevant design information, including Architects, Services, Civil and Structural Engineers drawings
 All existing site, tree, building and survey information has been compiled from different sources, including information supplied by third parties

NOT FOR CONSTRUCTION

- KEY:
- 1 Principal Entrance
Level access, cover provided by a canopy
 - 2 Dog Run
Outdoor access to contained space from Dog Kennels, area enclosed by acoustic fencing
 - 3 Dog Isolation Run
Outdoor access to contained space from Dog Isolation, area enclosed by acoustic fencing

See Dawson Williamson Architects Drawing C1098 102 for information in relation to Boundary Treatments
 - 4 Amenity Garden
Space for Staff
 - 5 Parking Spaces
Total number of parking spaces are 50, which includes 2 No accessible parking spaces

Parking Spaces are drawn as 2.5m (w) x 5m (l) with the exception of accessible spaces
 - 6 Site Entrance

See Dawson Williamson Architects Drawing C1098 104 / design information prepared prepared by VIA Solutions in relation to Travel, Highways, Vehicular Access and Car Parking matters
 - 7 2 No Accessible Car Parking Spaces
(See notes above)
 - 8 3 No EV Charging Points
(See notes above)
 - 9 Landscaped Buffer
 - 10 Soft Landscaping
 - 11 Cycle Parking
Covered / secure shelter for approximately 10 No Bicycles

See design information prepared prepared by VIA Solutions in relation to Travel, Highways, Vehicular Access and Car Parking matters
 - 12 Retaining Structures to Site Perimeter

See Dawson Williamson Architects Drawing Ref. C1098 103 / for information in relation to Boundary Treatments and design information prepared by JFG in relation to Levels, Drainage & Civil Engineering Matters
 - 13 Totem Signage at Site Entrance / Frontage
 - 14 Refuse Collection
Including clinical waste

Total Planning Application Site Area 3,681 sq.m
 Extents indicated by red line

- Rev 3 2025.04.15 Site entrance re-located & car parking layout updated following speed survey assessment by VIA Solutions (No of car parking spaces unaffected). Building reduced in size (two storey section, NE boundary). Amendments to Building Design made in response to comments from the Local Authority. Totem signage added to site entrance / frontage. Extent of retaining structures reduced. River Holme Buffer Zone identified
- Rev 2 2024.10.14 Drawing updated to suit design information received from third party consultants / design development by DWA
- Rev 1 2024.01.10 Scheme redesigned in response to Pre-application response from the Local Authority (see separate covering letter for further details). Drawing Updated to 'Planning' status

C1098 101 Rev 3

**TITLE PROPOSED DRAWING
SITE LAYOUT PLAN**

SCALE 1:250 @ A1; 1:500 @ A3

PLANNING

**PROJECT VETERINARY SURGERY
RIVERSIDE WORKS
WOODHEAD ROAD, HONLEY
HUDDERSFIELD
HD9 6PW**

CLIENT DONALDSON'S PROPERTIES LTD

**DAWSON WILLIAMSON
ARCHITECTS**

Bradford Edinburgh
 01274 551 300
 info@dawsonwilliamson.co.uk

THE DETAILS SHOWN ON THIS DRAWING ARE CONFIDENTIAL & THE DRAWING IS THE EXCLUSIVE PROPERTY OF DAWSON WILLIAMSON LTD. NO USE, COPY OR DISCLOSURE OF THE DRAWING MAY BE MADE WITHOUT OUR PERMISSION & THE DRAWING MUST BE RETURNED TO DAWSON WILLIAMSON LTD WHEN REQUIRED.
 © Dawson Williamson Ltd 2022



Appendix F LLFA Guidance

Consultation Response from KC, Lead Local Flood Authority		
2023/20223 at Riverside Works, Honley, Holmfirth, HD9 6PW		
Pre application for mixed commercial (1 unit) and residential development (7 flats)		
Date Responded: 18th April 2023	Responding Officer: Paul Farndale	Responding Ref:
<p>Topography</p> <p>The site (circa 0.35ha) appears from our mapping tool to have a fall toward the northeast at an average gradient of 1 in 5 to 1 in 6.</p> <p>Sequential Test and Flood Risk Assessment</p> <p>The site's red line boundary is below 1 hectare and entirely in flood zone 1. The blue boundary borders the river Holme. There is no need for a sequential test or a formal flood risk assessment. However, a drainage strategy will be required.</p> <p>Surface Water Flood Risk</p> <p>Third generation mapping of surface water flood risk does not reveal on catchment flood routes or identify any on site risk. There are no reported flood incidents in the immediate vicinity of the site.</p> <p>Watercourses</p> <p>The river Holme is adjacent to the blue line boundary and is classed as Main River. Please contact the Environment Agency for required buffer zones and consents required to work on or close to the bank.</p> <p>Surface Water Disposal</p> <p>SUDS infiltration techniques should be considered first. However, British Geological Survey suggests this area is zone 4, severe constraints. Also being so close to a watercourse the LLFA rules this out as an option.</p> <p>SUDS however do not have to include infiltration and can simply be used for improving the water quality of any discharge. Treatment is expected where a connection to watercourse is envisaged. Biodiversity and amenity benefits should also be considered when examining the use of SUDS techniques.</p> <p>A connection to watercourse is obvious with the river Holme former the blue line land boundary. Discharge will be restricted to 3l/s where existing positive drainage cannot be proved. A demonstration of where surface water currently drains to may increase this discharge allowance to a 30% reduction on existing peak discharges. Yards without formal drainage must be discounted from this assessment.</p> <p>A connection to public combined sewer will not be considered at this stage.</p>		

Surface Water Attenuation

Any attenuation required should pay attention to the difficulties of road adoption where an 'structure' spanning more than 900mm is located under the highway. An early conversation with Farhad Khatibi in our structures team is advised. We advise against the use of storage crates due to long term maintenance and management requirements. This does not apply where roads are to remain private.

Attenuation must cater for the 1 in 30-year critical storm event with an appropriate allowance for climate change (see NPPF). Volumes generated by storms with greater return period can be stored above ground if demonstrated as safe. Alternatively, the attenuation must cater for the 1 in 100-year critical storm event with an appropriate allowance for climate change.

Flood Routing

We would expect the drainage plan to look at flood routes (where water cannot drain to gullies in extreme events or escapes from the attenuation tank) and come up with a least strategy for the development that clearly avoids buildings and uses roads, parking and service areas and open spaces as safe conduits.

Section 106 – Management Company

The LPA is obligated under House of Commons Written Statement 161 to ensure the maintenance and management of sustainable drainage for the lifetime of the site. This includes the period from construction up until a date of adoption by the statutory undertaker (Yorkshire Water). There is no guarantee that systems will be adopted even if an agreement is signed to do so. It is vital therefore that an undertaking is ensured in the planning process to maintain these systems to manage flood risk. A detailed maintenance plan including access and safety is expected to be included so it can be enforced against non-compliance.

This will not be applicable for single ownership developments where a maintenance plan can be secured on condition.

Temporary Drainage

Run off can increase post soil and vegetation strip and the risk of sediment entering the local drainage systems and watercourses. A plan to manage risk of flooding to nearby property and land and to protect watercourses from pollution will be required.



Appendix G Root Protection Area Plan



**Appendix 5:
Tree Constraints Plan**

ADDRESS: Land at Woodhead Road, Honley,
Huddersfield, West Yorkshire, HD9 6PW.
JCA REF: 18440-E/AJB.

SCALE : 1:500 PAPER SIZE : A3
SURVEYED BY: AJB DRAWN BY: AJB APPROVED BY: LW

BRITISH STANDARD 5837:2012: 4.5
RETENTION CATEGORIES
Detailed definitions of these categories are at Appendix 2 of our report. N.B. These categories do not necessarily represent or correspond to recommendations for action made in this report.

	CATEGORY A: 'RETENTION MOST DESIRABLE'
	CATEGORY B: 'RETENTION DESIRABLE'
	CATEGORY C: 'TREE WHICH COULD BE RETAINED'
	CATEGORY L: 'TREE FOR REMOVAL'
	STEM OF TREE TO BE RETAINED
	STEM OF TREE TO BE REMOVED
	ROOT PROTECTION AREA
	ROOT PROTECTION AREA (PRIOR TO OFF-SETTING)



THIS PLAN IS TO BE PRINTED IN COLOUR
AND READ IN CONJUNCTION WITH THE
JCA ARBORICULTURAL REPORT
(JCA REF: 18440-E/AJB)

Root Protection Area: RPA
THE ROOT PROTECTION AREA SHOULD IDEALLY REMAIN UNDISTURBED IF THE TREE IS TO BE RETAINED.
THE DEVELOPMENT PROPOSALS SHOULD THEREFORE BE DESIGNED TO AVOID THE RPA OF ANY TREE WHICH IS TO BE RETAINED.
IF IT IS NECESSARY FOR THE DEVELOPMENT TO ENCROACH INTO THE RPA OF A TREE WHICH IS TO BE RETAINED THEN SPECIALIST CONSTRUCTION TECHNIQUES AND MATERIALS MUST BE CONSIDERED.



Appendix H Surface Water Strategy

DO NOT SCALE (A1)

NOTES

- GENERAL NOTES**
- ALL MATERIALS AND WORKMANSHIP IS TO COMPLY WITH JPG CONSULTANTS STANDARD SPECIFICATION & ALL RELEVANT BRITISH & EUROPEAN STANDARDS.
 - THIS DRAWING IS TO BE READ IN CONJUNCTION WITH ALL RELEVANT ARCHITECTS, M & E CONSULTANTS AND JPG CONSULTANTS DRAWINGS.
 - ANY DISCREPANCIES SHOULD BE REPORTED TO THE ENGINEER IMMEDIATELY SO THAT CLARIFICATION CAN BE SOUGHT PRIOR TO COMMENCEMENT OF WORKS.
- DRAINAGE NOTES**
- ALL BUILDING DRAINAGE WORKS SHALL BE CARRIED OUT IN ACCORDANCE WITH BS EN 752:2008 DRAINAGE AND SEWER SYSTEMS OUTSIDE BUILDINGS, THE CURRENT BUILDING REGULATIONS AND THE LOCAL AUTHORITY BUILDING CONTROL SPECIFICATIONS AND REQUIREMENTS.
 - ANY DRAINAGE TO BE PUT FORWARD FOR ADOPTION EITHER WITHIN THE SITE OR OUTSIDE SHALL BE CONSTRUCTED TO SEWERS FOR ADOPTION LATEST EDITION AND ANY SPECIFIC REQUIREMENTS OF THE ADOPTING SEWERAGE/WATER AUTHORITY.
 - THE LOCATION, SIZE AND DEPTH OF ALL EXISTING DRAINS/SEWERS AND SERVICES SHALL BE ESTABLISHED BY THE CONTRACTOR PRIOR TO THE COMMENCEMENT OF WORKS ON SITE. ANY DISCREPANCIES FROM THE INFORMATION INDICATED ON THESE DRAWINGS SHALL IMMEDIATELY BE BROUGHT TO THE ATTENTION OF THE ENGINEER.
 - THE CONTRACTOR SHALL IMMEDIATELY NOTIFY THE ENGINEER SHOULD ANY EXISTING LIVE DRAINAGE BE FOUND WITHIN THE SITE BOUNDARY SERVING ADJACENT PROPERTIES.
 - ALL EXISTING DRAINAGE WITHIN THE SITE NOT REQUIRED FOR THE NEW DEVELOPMENT SHALL BE ABANDONED. DRAINS AND SEWERS LESS THAN 1.500m DEEP WHICH ARE IN OPEN GROUND SHOULD AS FAR AS IS PRACTICABLE BE FULLY REMOVED. ALL OTHER PIPES SHOULD BE SEALED AT BOTH ENDS AND AT ANY POINT OF CONNECTION, AND BE GROUT FILLED TO ENSURE THAT RATS CANNOT GAIN ACCESS. LARGER PIPES 225Ø OR ABOVE SHOULD BE GROUT FILLED TO PREVENT SUBSIDENCE OR DAMAGE TO BUILDINGS OR SERVICES IN THE EVENT OF COLLAPSE.
 - THE CONTRACTOR SHALL ALLOW FOR THE PROTECTION, TEMPORARY AND PERMANENT SUPPORT AND DIVERSION WORKS AS NECESSARY, TO ALL EXISTING SERVICES TO THE SATISFACTION OF THE UTILITY COMPANIES.
 - THE CONTRACTOR SHALL ALLOW FOR DEALING WITH SURFACE WATER RUN OFF INTO EXCAVATIONS AND FROM GROUNDWATER BY MEANS OF SUMPS, PUMPING AND DE WATERING AS APPROPRIATE, IN ORDER TO KEEP THE EXCAVATION AS REASONABLY DRY AS POSSIBLE DURING THE CONSTRUCTION OF THE WORKS.
 - THE CONTRACTOR SHALL TAKE ALL NECESSARY SAFETY PRECAUTIONS IN LINE WITH CURRENT LEGISLATION WHEN WORKING IN/NEAR CONFINED SPACES, DEEP EXCAVATIONS AND MACHINERY.
 - THE CONTRACTOR SHALL ALLOW FOR OBTAINING ALL APPROVALS FROM THE RELEVANT AUTHORITIES WHEN WORKING IN THE PUBLIC HIGHWAY AND ON THE SEWERAGE SYSTEM.
 - THE CONTRACTOR SHALL SUITABLY PROTECT PEDESTRIANS AND VEHICLES FROM WORKING AREAS.
 - ALL MANHOLE/CHAMBER COVER LEVELS ARE APPROXIMATE AND SHALL BE ADJUSTED ON SITE TO SUIT THE PROPOSED FINISHED LEVELS.
 - ALL PIPES SHALL BE LAID WITH LEVEL SOFFITS AND ALL MANHOLE/INSPECTION CHAMBER INVERT LEVELS SHOWN ARE FOR THE OUT GOING PIPE UNDO. ON THE DRAWING (NOTE THAT ALL PIPE GRADIENTS INDICATED ON THE DRAWING ARE APPROXIMATE ONLY).
 - ALL PIPE CONNECTION FROM DRAINAGE CHANNELS AND GULLIES SHALL BE 150Ø PIPES AT A MINIMUM GRADIENT OF 1:100 WITH CLASS 2 BEDDING UNDO, ON THE DRAWING.
 - ALL PIPE CONNECTIONS FROM RWPS TO BE 100Ø AT 1:50 MIN. AND ALL PIPE CONNECTIONS FROM WPCS TO FIRST CHAMBER SHALL BE 100Ø AT 1:40 MIN. WITH CLASS 3 BEDDING BENEATH THE BUILDING AND CLASS 2 UNDER EXTERNALS WHERE COVER IS LESS THAN 1.20m UNDO. ON THE DRAWING (LOCATION OF RWPS AND WPCS TO BE CONFIRMED BY THE ARCHITECT AND ARE SHOWN INDICATIVELY ONLY).
 - ALL SYPHONIC RWP SYSTEMS TO BE DESIGNED BY OTHERS. PIPEWORK FROM DOWN PIPE TO FIRST MANHOLE TO BE SIZED/ DESIGNED BY SYPHONIC SYSTEM DESIGNER. THE FIRST MANHOLE TO HAVE AN OPEN GRATE COVER SAINT GABAIN WATERWAY 2000 - D400 OR SIMILAR APPROVED.
 - SUITABLY SIZED PETROL INTERCEPTORS MUST COMPLY WITH THE REQUIREMENTS OUTLINE IN PPG3 THESE INCLUDE SILT STORAGE CAPACITY AND HIGH LEVEL HYDROCARBON ALARM WIRING BACK TO A MANNED OFFICE.
 - UPON COMPLETION OF THE DRAINAGE WORKS THE CONTRACTOR SHALL CLEAN ALL DRAIN RUNS BY JETTING AND REMOVE ALL DEBRIS FROM SITE. NO DEBRIS SHALL BE PERMITTED TO ENTER THE PUBLIC SEWER AND/OR WATERCOURSE SYSTEM. ONCE THE DRAINAGE SYSTEM HAS BEEN FULLY CLEANED OUT A CCTV CAMERA CONDITION SURVEY SHALL BE UNDERTAKEN TO ALL CONSTRUCTED DRAINAGE AND SEWER PIPES WITH THE FOOTAGE ISSUED TO THE ENGINEER FOR VIEW. THE AS BUILT INVERT AND COVER LEVELS SHALL BE RECORDED BY THE CONTRACTOR AND PASSED ON TO THE ENGINEER FOR REVIEW.

- LEGEND**
- PROPOSED SURFACE WATER PIPE
 - PROPOSED SURFACE WATER MANHOLE
 - EXISTING COMBINED WATER PIPE
 - EXISTING COMBINED WATER MANHOLE
 - PROPOSED DRAINAGE CHANNEL
 - PROPOSED FILTERDRAIN
 - PROPOSED ROAD GULLY
 - PROPOSED RAINWATER PIPE
 - PROPOSED SITE BOUNDARY

NOTE
RAINWATER PIPES SUBJECT TO DETAILED DESIGN

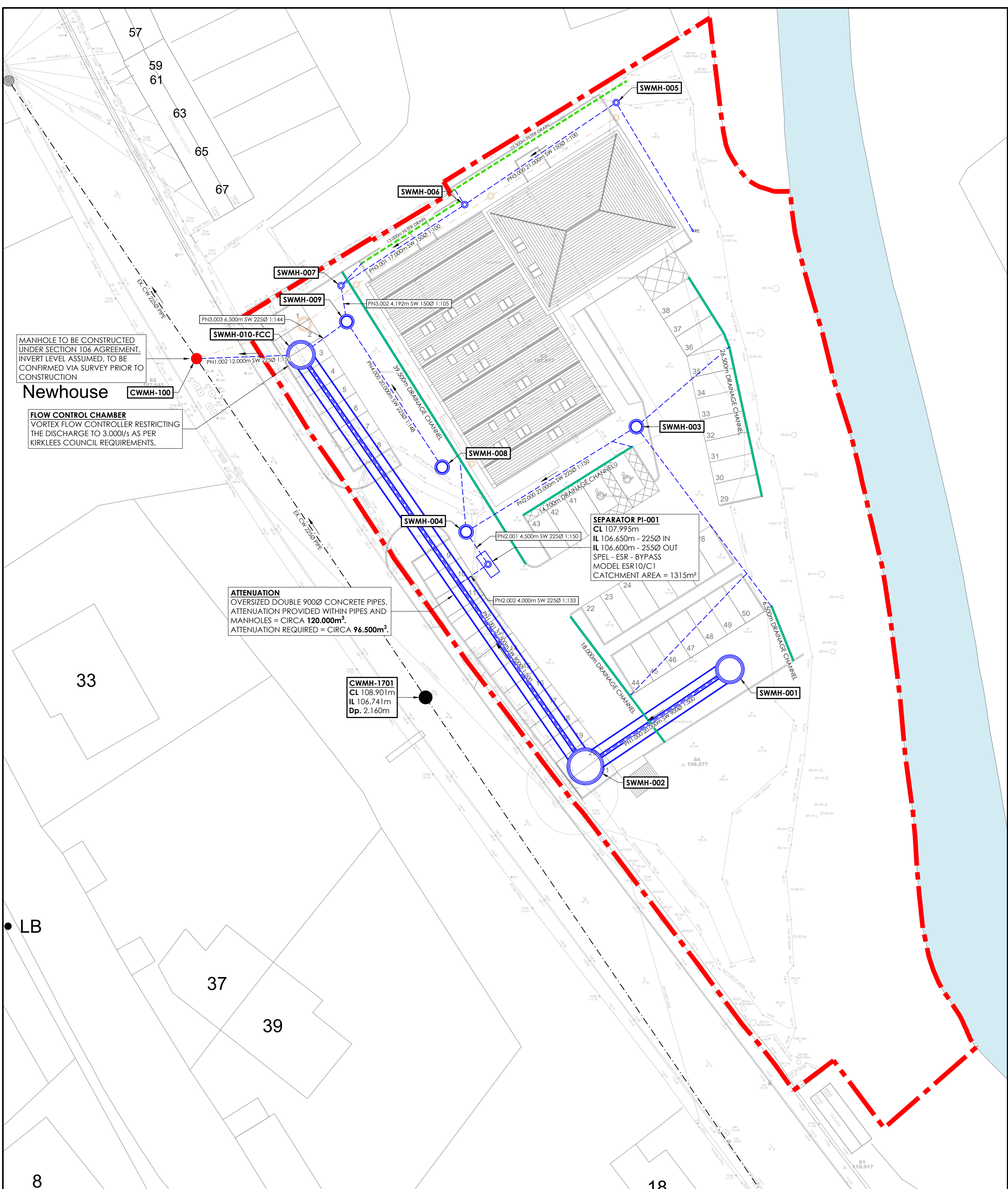
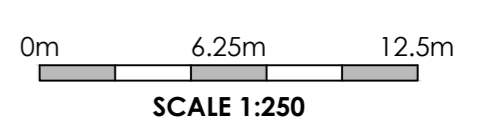

MANHOLE TO BE CONSTRUCTED UNDER SECTION 106 AGREEMENT. INVERT LEVEL ASSUMED, TO BE CONFIRMED VIA SURVEY PRIOR TO CONSTRUCTION

Newhouse

FLOW CONTROL CHAMBER
VORTEX FLOW CONTROLLER RESTRICTING THE DISCHARGE TO 3.000/s AS PER KIRKLEES COUNCIL REQUIREMENTS.

ATTENUATION
OVERSIZED DOUBLE 900Ø CONCRETE PIPES. ATTENUATION PROVIDED WITHIN PIPES AND MANHOLES = CIRCA 120.000m³. ATTENUATION REQUIRED = CIRCA 96.500m³.

SEPARATOR PI-001
CL 107.995m
IL 106.650m - 225Ø IN
IL 106.600m - 255Ø OUT
SPEL - ESR - BYPASS
MODEL ESR10/C1
CATCHMENT AREA = 1315m²

CWMH-1701
CL 108.901m
IL 106.741m
Dp. 2.160m

PLAN ON SURFACE WATER DRAINAGE
SCALE 1:250

6369-SW-DRAINAGE_NETWORK MANHOLE SCHEDULE

REF.	COVER LEVEL	INVERT LEVEL	SUMP DEPTH	DEPTH	EASTING	NORTHING	DIAMETER	TYPE	COVER	NOTES
PI-001	107.995m	106.625m - 225Ø IN 106.625m - 225Ø OUT	0.000m	1.370m	414178.235	411795.272	450Ø	SEPARATOR	600x600 - CLASS D400	-
001	108.110m	106.010m - 900Ø OUT	0.000m	2.100m	414206.025	411783.208	2700Ø	TYPE B	600x600 - CLASS D400	-
002	108.714m	105.970m - 900Ø IN 105.970m - 900Ø OUT	0.000m	2.744m	414189.427	411772.049	3600Ø	TYPE B	600x600 - CLASS D400	-
003	107.731m	106.809m - 225Ø OUT	0.000m	0.923m	414195.277	411811.095	1200Ø	TYPE C	600x600 - CLASS D400	-
004	107.861m	106.655m - 225Ø IN 106.655m - 225Ø OUT	0.000m	1.206m	414175.714	411799.000	1200Ø	TYPE C	600x600 - CLASS D400	-
005	107.822m	107.070m - 150Ø OUT	0.000m	0.752m	414192.965	411848.351	450Ø	PPIC	450x450 - CLASS B125	-
006	107.918m	106.860m - 150Ø IN 106.860m - 150Ø OUT	0.000m	1.058m	414175.550	411836.615	450Ø	PPIC	450x450 - CLASS B125	-
007	107.687m	106.690m - 150Ø IN 106.690m - 150Ø OUT	0.000m	0.997m	414161.330	411827.299	450Ø	PPIC	450x450 - CLASS B125	-
008	107.767m	106.710m - 225Ø OUT	0.000m	1.057m	414172.956	411806.432	1200Ø	TYPE C	600x600 - CLASS D400	-
009	107.708m	106.650m - 150Ø IN 106.575m - 225Ø IN 106.575m - 225Ø OUT	0.000m	1.133m	414161.993	411823.160	1200Ø	TYPE C	450x450 - CLASS B125	-
010-FCC	107.789m	106.530m - 225Ø IN 105.855m - 900Ø IN 105.855m - 225Ø OUT	0.500m	2.434m	414156.729	411819.347	2700Ø	TYPE B	1220x675 - CLASS C250	FLOW CONTROL CHAMBER
CWMH100	107.427m	105.775m - 225Ø IN 105.775m - 225Ø IN 105.775m - 225Ø OUT	0.000m	1.653m	414144.737	411818.913	1200Ø	TYPE C	600x600 - CLASS D400	INVERT LEVELS ASSUMED

REV	DESCRIPTION	DATE	CHK	BY
P05	REVISED TO SUIT UPDATED FINISHED LEVELS.	29.04.25	RMR	LSG
P04	PROPOSED OUTFALL TO EXISTING HIGHWAY NETWORK	05.09.24	RMR	SMS
P03	LAYOUT UPDATED TO SUIT RELOCATED OUTFALL.	09.08.24	RMR	SMS
P02	UPDATED TO YORKSHIRE WATER COMMENTS	18.07.24	RMR	SMS
P01	ISSUED FOR INFORMATION	28.05.24	JDM	SMS

Project
DONALDSON'S VETS
HONLEY

Drawing Title
SURFACE WATER DRAINAGE STRATEGY

INFORMATION





Appendix J Surface Water Network Attenuation and Hydraulic Model Calculations

Project: 6369 Donaldson Vets Honley	Date: 29/04/2025		
Report Details: Type: Inflows Storm Phase: 6369-SW-Drainage_Network	Designed by: MKJW	Checked by: JDM	Approved By: JDM
	Company Address: JPG Group 5 John Charles Way, Leeds LS12 6QA		



SWMH-004.1

Type : Catchment Area

Area (ha)	0.039
-----------	-------

Dynamic Sizing

Runoff Method	Time of Concentration
Summer Volumetric Runoff	0.750
Winter Volumetric Runoff	0.840
Time of Concentration (mins)	5
Percentage Impervious (%)	100



SWMH-004.2

Type : Catchment Area

Area (ha)	0.054
-----------	-------

Dynamic Sizing

Runoff Method	Time of Concentration
Summer Volumetric Runoff	0.750
Winter Volumetric Runoff	0.840
Time of Concentration (mins)	5
Percentage Impervious (%)	100



SWMH-005

Type : Catchment Area

Area (ha)	0.013
-----------	-------

Dynamic Sizing

Runoff Method	Time of Concentration
Summer Volumetric Runoff	0.750
Winter Volumetric Runoff	0.840
Time of Concentration (mins)	5
Percentage Impervious (%)	100

Project: 6369 Donaldson Vets Honley	Date: 29/04/2025		
	Designed by: MKJW	Checked by: JDM	Approved By: JDM
Report Details: Type: Inflows Storm Phase: 6369-SW-Drainage_Network	Company Address: JPG Group 5 John Charles Way, Leeds LS12 6QA		



SWMH-006.1

Type : Catchment Area

Area (ha)	0.009
-----------	-------

Dynamic Sizing

Runoff Method	Time of Concentration
Summer Volumetric Runoff	0.750
Winter Volumetric Runoff	0.840
Time of Concentration (mins)	5
Percentage Impervious (%)	100



SWMH-006.2

Type : Catchment Area

Area (ha)	0.013
-----------	-------

Dynamic Sizing

Runoff Method	Time of Concentration
Summer Volumetric Runoff	0.750
Winter Volumetric Runoff	0.840
Time of Concentration (mins)	5
Percentage Impervious (%)	100



SWHM-007

Type : Catchment Area

Area (ha)	0.003
-----------	-------

Dynamic Sizing

Runoff Method	Time of Concentration
Summer Volumetric Runoff	0.750
Winter Volumetric Runoff	0.840
Time of Concentration (mins)	5
Percentage Impervious (%)	100

Project: 6369 Donaldson Vets Honley	Date: 29/04/2025			
	Designed by: MKJW	Checked by: JDM	Approved By: JDM	
Report Details: Type: Inflows Storm Phase: 6369-SW-Drainage_Network	Company Address: JPG Group 5 John Charles Way, Leeds LS12 6QA			



SWMH-009

Type : Catchment Area

Area (ha)	0.033
-----------	-------

Dynamic Sizing

Runoff Method	Time of Concentration
Summer Volumetric Runoff	0.750
Winter Volumetric Runoff	0.840
Time of Concentration (mins)	5
Percentage Impervious (%)	100



SWMH-008

Type : Catchment Area

Area (ha)	0.012
-----------	-------

Dynamic Sizing

Runoff Method	Time of Concentration
Summer Volumetric Runoff	0.750
Winter Volumetric Runoff	0.840
Time of Concentration (mins)	5
Percentage Impervious (%)	100



SWMH-003.2

Type : Catchment Area

Area (ha)	0.041
-----------	-------

Dynamic Sizing

Runoff Method	Time of Concentration
Summer Volumetric Runoff	0.750
Winter Volumetric Runoff	0.840
Time of Concentration (mins)	5
Percentage Impervious (%)	100

Project: 6369 Donaldson Vets Honley	Date: 29/04/2025	Designed by: MKJW	Checked by: JDM	Approved By: JDM	
Report Details: Type: Inflows Storm Phase: 6369-SW-Drainage_Network	Company Address: JPG Group 5 John Charles Way, Leeds LS12 6QA				



SWMH-003.1

Type : Catchment Area

Area (ha)	0.037
-----------	-------

Dynamic Sizing

Runoff Method	Time of Concentration
Summer Volumetric Runoff	0.750
Winter Volumetric Runoff	0.750
Time of Concentration (mins)	5
Percentage Impervious (%)	100

Project: 6369 Donaldson Vets Honley		Date: 29/04/2025		
Report Details: Type: Junctions Storm Phase: 6369-SW-Drainage_Network		Designed by: MKJW	Checked by: JDM	Approved By: JDM
		Company Address: JPG Group 5 John Charles Way, Leeds LS12 6QA		



Name	Junction Type	Easting (m)	Northing (m)	Cover Level (m)	Depth (m)	Invert Level (m)	Sump Depth (m)	Chamber Shape
PI-001	Manhole	414178.235	411795.272	107.995	1.370	106.625	0.000	Circular
006	Manhole	414175.550	411836.615	107.918	1.058	106.860	0.000	Circular
004	Manhole	414175.714	411799.000	107.861	1.206	106.655	0.000	Circular
005	Manhole	414192.965	411848.351	107.822	0.752	107.070	0.000	Circular
010-FCC	Manhole	414156.729	411819.347	107.789	2.434	105.355	0.500	Circular
008	Manhole	414172.956	411806.432	107.767	1.057	106.710	0.000	Circular
003	Manhole	414195.277	411811.095	107.731	0.923	106.809	0.000	Circular
009	Manhole	414161.993	411823.160	107.708	1.133	106.575	0.000	Circular
007	Manhole	414161.330	411827.299	107.687	0.997	106.690	0.000	Circular
100	Manhole	414144.737	411818.913	107.427	1.653	105.775	0.000	Circular
001	Manhole	414206.025	411783.208	108.110	2.100	106.010	0.000	Circular
SWMH-002	Manhole	414189.427	411772.049	108.714	2.744	105.970	0.000	Circular
Simple Junction (3)	Simple Junction	414143.265	411822.289					
Simple Junction	Simple Junction	414174.869	411793.108					

Name	Diameter (m)	Part Family	Lock
PI-001	2.700	Type B	All
006	0.450	PPIC	All
004	1.200	Type E	All
005	0.450	PPIC	All
010-FCC	2.700	Type B	All
008	1.200	Type E	All
003	1.200	Type E	All
009	1.200	Type E	All
007	0.450	PPIC	All
100	1.200	Type E	All
001	2.700	Type B	All
SWMH-002	3.600		All
Simple Junction (3)			
Simple Junction			

Project: 6369 Donaldson Vets Honley	Date: 29/04/2025	Designed by: MKJW	Checked by: JDM	Approved By: JDM	
Report Details: Type: Junctions Storm Phase: 6369-SW-Drainage_Network	Company Address: JPG Group 5 John Charles Way, Leeds LS12 6QA				

Outlets

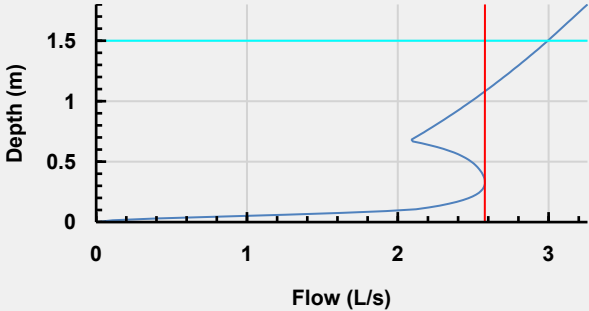
Junction	Outlet Name	Outgoing Connection	Outlet Type	
PI-001	Outlet	2.002	Free Discharge	
006	Outlet	3.001	Free Discharge	
004	Outlet	2.001	Free Discharge	
005	Outlet	3.000	Free Discharge	
010-FCC	Outlet	1.002	Hydro-Brake®	
	Invert Level (m)	105.855		
	Design Depth (m)	1.500		
	Design Flow (L/s)	3.0		
	Objective	Minimise Upstream Storage Requirements		
	Application	Surface Water Only		
	Sump Available	<input checked="" type="checkbox"/>		
	Unit Reference	SHE-0075-3000-1500-3000		
				
	008	Outlet	4.000	Free Discharge
003	Outlet	2.000	Free Discharge	
009	Outlet	3.003	Free Discharge	
007	Outlet	3.002	Free Discharge	
100	Outlet	EX'G	Free Discharge	
001	Outlet	1.000	Free Discharge	
SWMH-002	Outlet	1.001	Free Discharge	
Simple Junction	Outlet	1.001 (1)	Free Discharge	

Project: 6369 Donaldson Vets Honley		Date: 29/04/2025		
Report Details: Type: Connections Storm Phase: 6369-SW-Drainage_Network		Designed by: MKJW	Checked by: JDM	Approved By: JDM
		Company Address: JPG Group 5 John Charles Way, Leeds LS12 6QA		



Name	Length (m)	Connection Type	Slope (1:X)	Manning's n	Colebrook-White Roughness (mm)	Diameter / Base Width (mm)	Upstream Cover Level (m)	Upstream Invert Level (m)
2.001	4.500	Pipe	149.925		0.6	225	107.861	106.655
2.000	23.000	Pipe	149.561		0.6	225	107.731	106.809
1.002	12.000	Pipe	149.925		0.6	225	107.789	105.855
EX'G	3.683	Pipe	40.000		0.6	225	107.427	105.775
3.003	6.500	Pipe	144.444		0.6	225	107.708	106.575
3.000	21.000	Pipe	100.000		0.6	150	107.822	107.070
3.001	17.000	Pipe	100.000		0.6	150	107.918	106.860
4.000	20.000	Pipe	148.148		0.6	225	107.767	106.710
3.002	4.192	Pipe	104.789		0.6	150	107.687	106.690
1.000	20.000	Pipe	500.000		0.6	900	108.110	106.010
1.001	25.601	Pipe	500.000		0.6	900	108.714	105.970
1.001 (1)	31.899	Pipe	500.000		0.6	900	108.302	105.919
2.002	4.002	Pipe	133.408		0.6	225	107.995	106.625

Name	Downstream Cover Level (m)	Downstream Invert Level (m)	Part Family	Lock	Flow Restriction (L/s)	Culvert Type	Culvert Entrance
2.001	107.995	106.625	Clay Pipe SI	All		(None)	(None)
2.000	107.861	106.655	Clay Pipe SI	All		(None)	(None)
1.002	107.427	105.775	Clay Pipe SI	All	3.3	(None)	(None)
EX'G	105.908	105.683	Clay Pipe SI	All		(None)	(None)
3.003	107.789	106.530	Clay Pipe SI	All		(None)	(None)
3.000	107.918	106.860	Clay Pipe SI	All		(None)	(None)
3.001	107.687	106.690	Clay Pipe SI	All		(None)	(None)
4.000	107.708	106.575	Clay Pipe SI	All		(None)	(None)
3.002	107.708	106.650	Clay Pipe SI	All		(None)	(None)
1.000	108.714	105.970	Concrete Pipe SI	All		(None)	(None)
1.001	108.302	105.919	Concrete Pipe SI	All		(None)	(None)
1.001 (1)	107.789	105.855	Concrete Pipe SI	All		(None)	(None)
2.002	108.302	106.595		All		(None)	(None)

Project: 6369 Donaldson Vets Honley	Date: 29/04/2025	Designed by: MKJW	Checked by: JDM	Approved By: JDM	
Report Details: Type: Network Design Criteria Storm Phase: 6369-SW-Drainage_Network	Company Address: JPG Group 5 John Charles Way, Leeds LS12 6QA				

Flow Options

Peak Flow Calculation	(UK) Modified Rational Method
Min. Time of Entry (mins)	5
Max. Travel Time (mins)	30

Pipe Options

Lock Slope Options	None
Design Options	Minimise Excavation
Design Level	Level Soffits
Min. Cover Depth (m)	1.200
Min. Slope (1:X)	500.00
Max. Slope (1:X)	40.00
Min. Velocity (m/s)	1.0
Max. Velocity (m/s)	3.0
Use Flow Restriction	<input type="checkbox"/>
Reduce Channel Depths	<input type="checkbox"/>

Manhole Options

Apply Offset	<input type="checkbox"/>
--------------	--------------------------

Project: 6369 Donaldson Vets Honley	Date: 29/04/2025			
	Designed by: MKJW	Checked by: JDM	Approved By: JDM	
Report Details: Type: Outfall Details Storm Phase: 6369-SW-Drainage_Network	Company Address: JPG Group 5 John Charles Way, Leeds LS12 6QA			

Outfalls

Outfall	Outfall Type	Gated	Fixed Surcharged Level (m)	Level Curve
Simple Junction (3)	Free Discharge			

Project: 6369 Donaldson Vets Honley	Date: 29/04/2025		
	Designed by: MKJW	Checked by: JDM	Approved By: JDM
Report Title: Rainfall Analysis Criteria	Company Address: JPG Group 5 John Charles Way, Leeds LS12 6QA		



Runoff Type	Dynamic
Output Interval (mins)	5
Time Step	Default
Urban Creep	Apply Global Value
Urban Creep Global Value (%)	0
Junction Flood Risk Margin (mm)	300
Prefill Manhole Sumps	<input type="checkbox"/>
Perform No Discharge Analysis	<input type="checkbox"/>

Project: 6369 Donaldson Vets Honley	Date: 29/04/2025	Designed by: MKJW	Checked by: JDM	Approved By: JDM	
Report Details: Type: Inflows Summary Storm Phase: 6369-SW-Drainage_Network	Company Address: JPG Group 5 John Charles Way, Leeds LS12 6QA				



Critical Storm Per Item: Rank By: Max. Inflow

Inflow	Storm Event	Inflow Area (ha)	Max. Inflow (L/s)	Total Inflow Volume (m³)
SWMH-004.1	1 IN 2: 2 years: +0 %: 15 mins: Winter	0.04	6.3	2.928
SWMH-004.2	1 IN 2: 2 years: +0 %: 15 mins: Winter	0.05	8.7	4.042
SWMH-005	1 IN 2: 2 years: +0 %: 15 mins: Winter	0.01	2.1	0.992
SWMH-006.1	1 IN 2: 2 years: +0 %: 15 mins: Winter	0.01	1.5	0.701
SWMH-006.2	1 IN 2: 2 years: +0 %: 15 mins: Winter	0.01	2.2	0.998
SWHM-007	1 IN 2: 2 years: +0 %: 15 mins: Winter	0.00	0.5	0.255
SWMH-009	1 IN 2: 2 years: +0 %: 15 mins: Winter	0.03	5.3	2.466
SWMH-008	1 IN 2: 2 years: +0 %: 15 mins: Winter	0.01	1.9	0.878
SWMH-003.2	1 IN 2: 2 years: +0 %: 15 mins: Winter	0.04	6.6	3.045
SWMH-003.1	1 IN 2: 2 years: +0 %: 15 mins: Summer	0.04	5.6	2.454

Project: 6369 Donaldson Vets Honley	Date: 29/04/2025	Designed by: MKJW		Checked by: JDM	Approved By: JDM	
Report Details: Type: Junctions Summary Storm Phase: 6369-SW-Drainage_Network	Company Address: JPG Group 5 John Charles Way, Leeds LS12 6QA					



Critical Storm Per Item: Rank By: Max. Resident Volume

Junction	Storm Event	Cover Level (m)	Invert Level (m)	Max. Level (m)	Max. Depth (m)	Max. Inflow (L/s)	Max. Resident Volume (m³)	Max. Flooded Volume (m³)	Max. Outflow (L/s)	Total Discharge Volume (m³)	Status
PI-001	1 IN 2: 2 years: +0 %: 15 mins: Winter	107.9 95	106.6 25	106.75 7	0.132	25.4	0.759	0.000	23.7	12.405	OK
006	1 IN 2: 2 years: +0 %: 15 mins: Winter	107.9 18	106.8 60	106.91 9	0.059	5.8	0.009	0.000	5.5	2.686	OK
004	1 IN 2: 2 years: +0 %: 15 mins: Winter	107.8 61	106.6 55	106.80 3	0.148	26.6	0.167	0.000	25.4	12.452	OK
005	1 IN 2: 2 years: +0 %: 15 mins: Winter	107.8 22	107.0 70	107.10 5	0.035	2.1	0.005	0.000	2.1	0.990	OK
010-FCC	1 IN 2: 2 years: +0 %: 180 mins: Winter	107.7 89	105.3 55	106.17 5	0.820	4.5	4.696	0.000	2.6	42.965	Surcharged
008	1 IN 2: 2 years: +0 %: 15 mins: Winter	107.7 67	106.7 10	106.74 0	0.030	1.9	0.034	0.000	1.8	0.876	OK
003	1 IN 2: 2 years: +0 %: 15 mins: Summer	107.7 31	106.8 09	106.88 8	0.079	11.9	0.090	0.000	11.5	5.166	OK
009	1 IN 2: 2 years: +0 %: 15 mins: Winter	107.7 08	106.5 75	106.66 5	0.090	13.0	0.102	0.000	12.3	6.270	OK
007	1 IN 2: 2 years: +0 %: 15 mins: Winter	107.6 87	106.6 90	106.75 6	0.066	6.0	0.011	0.000	5.8	2.937	OK
100	1 IN 2: 2 years: +0 %: 180 mins: Winter	107.4 27	105.7 75	105.80 4	0.029	2.6	0.033	0.000	2.6	42.909	OK
001	1 IN 2: 2 years: +0 %: 180 mins: Winter	108.1 10	106.0 10	106.17 5	0.165	1.1	0.946	0.000	0.3	2.640	OK
SWMH-002	1 IN 2: 2 years: +0 %: 180 mins: Winter	108.7 14	105.9 70	106.17 5	0.205	3.6	2.088	0.000	1.1	12.375	OK
Simple Junction (3)	1 IN 2: 2 years: +0 %: 15 mins: Summer		105.6 83	105.70 9	0.026	2.4			2.4	2.815	OK
Simple Junction	1 IN 2: 2 years: +0 %: 15 mins: Summer		105.9 19	106.07 0	0.151	22.9			18.3	8.612	OK

Project: 6369 Donaldson Vets Honley		Date: 29/04/2025		
Report Details: Type: Connections Summary Storm Phase: 6369-SW-Drainage_Network		Designed by: MKJW	Checked by: JDM	Approved By: JDM
		Company Address: JPG Group 5 John Charles Way, Leeds LS12 6QA		



Critical Storm Per Item: Rank By: Max. Flow

Connection	Storm Event	Connection Type	From	To	Upstream Cover Level (m)	Max. US Water Level (m)	Max. Flow Depth (m)	Discharge Volume (m³)	Max. Velocity (m/s)	Flow / Capacity	Max. Flow (L/s)	Status
2.001	1 IN 2: 2 years: +0 %: 15 mins: Winter	Pipe	004	PI-001	107.861	106.803	0.140	12.452	1.0	0.6	25.4	OK
2.000	1 IN 2: 2 years: +0 %: 15 mins: Winter	Pipe	003	004	107.731	106.888	0.113	5.493	0.6	0.27	11.5	OK
1.002	1 IN 2: 2 years: +0 %: 180 mins: Winter	Pipe	010-FCC	100	107.789	106.175	0.034	42.938	0.7	0.06	2.6	Surcharged
EX'G	1 IN 2: 2 years: +0 %: 180 mins: Winter	Pipe	100	Simple Junction (3)	107.427	105.804	0.028	42.909	0.9	0.03	2.6	OK
3.003	1 IN 2: 2 years: +0 %: 15 mins: Winter	Pipe	009	010-FCC	107.708	106.665	0.086	6.270	0.9	0.28	12.3	OK
3.000	1 IN 2: 2 years: +0 %: 15 mins: Winter	Pipe	005	006	107.822	107.105	0.047	0.990	0.4	0.12	2.1	OK
3.001	1 IN 2: 2 years: +0 %: 15 mins: Winter	Pipe	006	007	107.918	106.919	0.063	2.686	0.8	0.31	5.5	OK
4.000	1 IN 2: 2 years: +0 %: 15 mins: Winter	Pipe	008	009	107.767	106.740	0.060	0.876	0.2	0.04	1.8	OK
3.002	1 IN 2: 2 years: +0 %: 15 mins: Winter	Pipe	007	009	107.687	106.756	0.063	2.937	0.8	0.34	5.8	OK
1.000	1 IN 2: 2 years: +0 %: 15 mins: Summer	Pipe	001	SWMH-002	108.110	106.068	0.079	0.000	0.0	0	1.0	OK
1.001	1 IN 2: 2 years: +0 %: 15 mins: Summer	Pipe	SWMH-002	Simple Junction	108.714	106.070	0.126	0.000	0.0	0	2.0	OK
1.001 (1)	1 IN 2: 2 years: +0 %: 15 mins: Summer	Pipe	Simple Junction	010-FCC	108.302	106.070	0.182	4.203	0.3	0.01	18.3	OK
2.002	1 IN 2: 2 years: +0 %: 15 mins: Winter	Pipe	PI-001	Simple Junction	107.995	106.757	0.124	12.405	1.1	0.53	23.7	OK

Project: 6369 Donaldson Vets Honley	Date: 29/04/2025		
Report Details: Type: Inflows Storm Phase: 6369-SW-Drainage_Network	Designed by: MKJW	Checked by: JDM	Approved By: JDM
	Company Address: JPG Group 5 John Charles Way, Leeds LS12 6QA		



SWMH-004.1

Type : Catchment Area

Area (ha)	0.039
-----------	-------

Dynamic Sizing

Runoff Method	Time of Concentration
Summer Volumetric Runoff	0.750
Winter Volumetric Runoff	0.840
Time of Concentration (mins)	5
Percentage Impervious (%)	100



SWMH-004.2

Type : Catchment Area

Area (ha)	0.054
-----------	-------

Dynamic Sizing

Runoff Method	Time of Concentration
Summer Volumetric Runoff	0.750
Winter Volumetric Runoff	0.840
Time of Concentration (mins)	5
Percentage Impervious (%)	100



SWMH-005

Type : Catchment Area

Area (ha)	0.013
-----------	-------

Dynamic Sizing

Runoff Method	Time of Concentration
Summer Volumetric Runoff	0.750
Winter Volumetric Runoff	0.840
Time of Concentration (mins)	5
Percentage Impervious (%)	100

Project: 6369 Donaldson Vets Honley	Date: 29/04/2025	Designed by: MKJW	Checked by: JDM	Approved By: JDM	
Report Details: Type: Inflows Storm Phase: 6369-SW-Drainage_Network	Company Address: JPG Group 5 John Charles Way, Leeds LS12 6QA				



SWMH-006.1

Type : Catchment Area

Area (ha)	0.009
-----------	-------

Dynamic Sizing

Runoff Method	Time of Concentration
Summer Volumetric Runoff	0.750
Winter Volumetric Runoff	0.840
Time of Concentration (mins)	5
Percentage Impervious (%)	100



SWMH-006.2

Type : Catchment Area

Area (ha)	0.013
-----------	-------

Dynamic Sizing

Runoff Method	Time of Concentration
Summer Volumetric Runoff	0.750
Winter Volumetric Runoff	0.840
Time of Concentration (mins)	5
Percentage Impervious (%)	100



SWHM-007

Type : Catchment Area

Area (ha)	0.003
-----------	-------

Dynamic Sizing

Runoff Method	Time of Concentration
Summer Volumetric Runoff	0.750
Winter Volumetric Runoff	0.840
Time of Concentration (mins)	5
Percentage Impervious (%)	100

Project: 6369 Donaldson Vets Honley	Date: 29/04/2025		
Report Details: Type: Inflows Storm Phase: 6369-SW-Drainage_Network	Designed by: MKJW	Checked by: JDM	Approved By: JDM
	Company Address: JPG Group 5 John Charles Way, Leeds LS12 6QA		



SWMH-009

Type : Catchment Area

Area (ha)	0.033
-----------	-------

Dynamic Sizing

Runoff Method	Time of Concentration
Summer Volumetric Runoff	0.750
Winter Volumetric Runoff	0.840
Time of Concentration (mins)	5
Percentage Impervious (%)	100



SWMH-008

Type : Catchment Area

Area (ha)	0.012
-----------	-------

Dynamic Sizing

Runoff Method	Time of Concentration
Summer Volumetric Runoff	0.750
Winter Volumetric Runoff	0.840
Time of Concentration (mins)	5
Percentage Impervious (%)	100



SWMH-003.2

Type : Catchment Area

Area (ha)	0.041
-----------	-------

Dynamic Sizing

Runoff Method	Time of Concentration
Summer Volumetric Runoff	0.750
Winter Volumetric Runoff	0.840
Time of Concentration (mins)	5
Percentage Impervious (%)	100

Project: 6369 Donaldson Vets Honley	Date: 29/04/2025		
	Designed by: MKJW	Checked by: JDM	Approved By: JDM
Report Details: Type: Inflows Storm Phase: 6369-SW-Drainage_Network	Company Address: JPG Group 5 John Charles Way, Leeds LS12 6QA		



SWMH-003.1

Type : Catchment Area

Area (ha)	0.037
-----------	-------

Dynamic Sizing

Runoff Method	Time of Concentration
Summer Volumetric Runoff	0.750
Winter Volumetric Runoff	0.750
Time of Concentration (mins)	5
Percentage Impervious (%)	100

Project: 6369 Donaldson Vets Honley		Date: 29/04/2025		
Report Details: Type: Junctions Storm Phase: 6369-SW-Drainage_Network		Designed by: MKJW	Checked by: JDM	Approved By: JDM
		Company Address: JPG Group 5 John Charles Way, Leeds LS12 6QA		



Name	Junction Type	Easting (m)	Northing (m)	Cover Level (m)	Depth (m)	Invert Level (m)	Sump Depth (m)	Chamber Shape
PI-001	Manhole	414178.235	411795.272	107.995	1.370	106.625	0.000	Circular
006	Manhole	414175.550	411836.615	107.918	1.058	106.860	0.000	Circular
004	Manhole	414175.714	411799.000	107.861	1.206	106.655	0.000	Circular
005	Manhole	414192.965	411848.351	107.822	0.752	107.070	0.000	Circular
010-FCC	Manhole	414156.729	411819.347	107.789	2.434	105.355	0.500	Circular
008	Manhole	414172.956	411806.432	107.767	1.057	106.710	0.000	Circular
003	Manhole	414195.277	411811.095	107.731	0.923	106.809	0.000	Circular
009	Manhole	414161.993	411823.160	107.708	1.133	106.575	0.000	Circular
007	Manhole	414161.330	411827.299	107.687	0.997	106.690	0.000	Circular
100	Manhole	414144.737	411818.913	107.427	1.653	105.775	0.000	Circular
001	Manhole	414206.025	411783.208	108.110	2.100	106.010	0.000	Circular
SWMH-002	Manhole	414189.427	411772.049	108.714	2.744	105.970	0.000	Circular
Simple Junction (3)	Simple Junction	414143.265	411822.289					
Simple Junction	Simple Junction	414174.869	411793.108					

Name	Diameter (m)	Part Family	Lock
PI-001	2.700	Type B	All
006	0.450	PPIC	All
004	1.200	Type E	All
005	0.450	PPIC	All
010-FCC	2.700	Type B	All
008	1.200	Type E	All
003	1.200	Type E	All
009	1.200	Type E	All
007	0.450	PPIC	All
100	1.200	Type E	All
001	2.700	Type B	All
SWMH-002	3.600		All
Simple Junction (3)			
Simple Junction			

Project: 6369 Donaldson Vets Honley	Date: 29/04/2025	Designed by: MKJW	Checked by: JDM	Approved By: JDM	
Report Details: Type: Junctions Storm Phase: 6369-SW-Drainage_Network	Company Address: JPG Group 5 John Charles Way, Leeds LS12 6QA				

Outlets

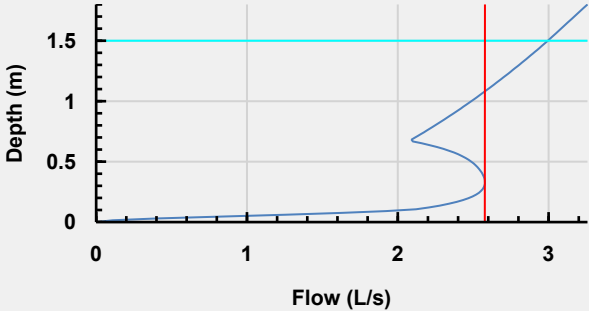
Junction	Outlet Name	Outgoing Connection	Outlet Type	
PI-001	Outlet	2.002	Free Discharge	
006	Outlet	3.001	Free Discharge	
004	Outlet	2.001	Free Discharge	
005	Outlet	3.000	Free Discharge	
010-FCC	Outlet	1.002	Hydro-Brake®	
	Invert Level (m)	105.855		
	Design Depth (m)	1.500		
	Design Flow (L/s)	3.0		
	Objective	Minimise Upstream Storage Requirements		
	Application	Surface Water Only		
	Sump Available	<input checked="" type="checkbox"/>		
	Unit Reference	SHE-0075-3000-1500-3000		
				
	008	Outlet	4.000	Free Discharge
003	Outlet	2.000	Free Discharge	
009	Outlet	3.003	Free Discharge	
007	Outlet	3.002	Free Discharge	
100	Outlet	EX'G	Free Discharge	
001	Outlet	1.000	Free Discharge	
SWMH-002	Outlet	1.001	Free Discharge	
Simple Junction	Outlet	1.001 (1)	Free Discharge	

Project: 6369 Donaldson Vets Honley		Date: 29/04/2025		
Report Details: Type: Connections Storm Phase: 6369-SW-Drainage_Network		Designed by: MKJW	Checked by: JDM	Approved By: JDM
		Company Address: JPG Group 5 John Charles Way, Leeds LS12 6QA		



Name	Length (m)	Connection Type	Slope (1:X)	Manning's n	Colebrook-White Roughness (mm)	Diameter / Base Width (mm)	Upstream Cover Level (m)	Upstream Invert Level (m)
2.001	4.500	Pipe	149.925		0.6	225	107.861	106.655
2.000	23.000	Pipe	149.561		0.6	225	107.731	106.809
1.002	12.000	Pipe	149.925		0.6	225	107.789	105.855
EX'G	3.683	Pipe	40.000		0.6	225	107.427	105.775
3.003	6.500	Pipe	144.444		0.6	225	107.708	106.575
3.000	21.000	Pipe	100.000		0.6	150	107.822	107.070
3.001	17.000	Pipe	100.000		0.6	150	107.918	106.860
4.000	20.000	Pipe	148.148		0.6	225	107.767	106.710
3.002	4.192	Pipe	104.789		0.6	150	107.687	106.690
1.000	20.000	Pipe	500.000		0.6	900	108.110	106.010
1.001	25.601	Pipe	500.000		0.6	900	108.714	105.970
1.001 (1)	31.899	Pipe	500.000		0.6	900	108.302	105.919
2.002	4.002	Pipe	133.408		0.6	225	107.995	106.625

Name	Downstream Cover Level (m)	Downstream Invert Level (m)	Part Family	Lock	Flow Restriction (L/s)	Culvert Type	Culvert Entrance
2.001	107.995	106.625	Clay Pipe SI	All		(None)	(None)
2.000	107.861	106.655	Clay Pipe SI	All		(None)	(None)
1.002	107.427	105.775	Clay Pipe SI	All	3.3	(None)	(None)
EX'G	105.908	105.683	Clay Pipe SI	All		(None)	(None)
3.003	107.789	106.530	Clay Pipe SI	All		(None)	(None)
3.000	107.918	106.860	Clay Pipe SI	All		(None)	(None)
3.001	107.687	106.690	Clay Pipe SI	All		(None)	(None)
4.000	107.708	106.575	Clay Pipe SI	All		(None)	(None)
3.002	107.708	106.650	Clay Pipe SI	All		(None)	(None)
1.000	108.714	105.970	Concrete Pipe SI	All		(None)	(None)
1.001	108.302	105.919	Concrete Pipe SI	All		(None)	(None)
1.001 (1)	107.789	105.855	Concrete Pipe SI	All		(None)	(None)
2.002	108.302	106.595		All		(None)	(None)

Project: 6369 Donaldson Vets Honley	Date: 29/04/2025	Designed by: MKJW	Checked by: JDM	Approved By: JDM	
Report Details: Type: Network Design Criteria Storm Phase: 6369-SW-Drainage_Network	Company Address: JPG Group 5 John Charles Way, Leeds LS12 6QA				

Flow Options

Peak Flow Calculation	(UK) Modified Rational Method
Min. Time of Entry (mins)	5
Max. Travel Time (mins)	30

Pipe Options

Lock Slope Options	None
Design Options	Minimise Excavation
Design Level	Level Soffits
Min. Cover Depth (m)	1.200
Min. Slope (1:X)	500.00
Max. Slope (1:X)	40.00
Min. Velocity (m/s)	1.0
Max. Velocity (m/s)	3.0
Use Flow Restriction	<input type="checkbox"/>
Reduce Channel Depths	<input type="checkbox"/>

Manhole Options

Apply Offset	<input type="checkbox"/>
--------------	--------------------------

Project: 6369 Donaldson Vets Honley	Date: 29/04/2025			
	Designed by: MKJW	Checked by: JDM	Approved By: JDM	
Report Details: Type: Outfall Details Storm Phase: 6369-SW-Drainage_Network	Company Address: JPG Group 5 John Charles Way, Leeds LS12 6QA			

Outfalls

Outfall	Outfall Type	Gated	Fixed Surcharged Level (m)	Level Curve
Simple Junction (3)	Free Discharge			

Project: 6369 Donaldson Vets Honley	Date: 29/04/2025		
	Designed by: MKJW	Checked by: JDM	Approved By: JDM
Report Title: Rainfall Analysis Criteria	Company Address: JPG Group 5 John Charles Way, Leeds LS12 6QA		



Runoff Type	Dynamic
Output Interval (mins)	5
Time Step	Default
Urban Creep	Apply Global Value
Urban Creep Global Value (%)	0
Junction Flood Risk Margin (mm)	300
Prefill Manhole Sumps	<input type="checkbox"/>
Perform No Discharge Analysis	<input type="checkbox"/>

Project: 6369 Donaldson Vets Honley	Date: 29/04/2025	Designed by: MKJW	Checked by: JDM	Approved By: JDM	
Report Details: Type: Inflows Summary Storm Phase: 6369-SW-Drainage_Network	Company Address: JPG Group 5 John Charles Way, Leeds LS12 6QA				



Critical Storm Per Item: Rank By: Max. Inflow

Inflow	Storm Event	Inflow Area (ha)	Max. Inflow (L/s)	Total Inflow Volume (m³)
SWMH-004.1	1 IN 30: 30 years: +0 %: 15 mins: Winter	0.04	12.0	5.536
SWMH-004.2	1 IN 30: 30 years: +0 %: 15 mins: Winter	0.05	16.5	7.643
SWMH-005	1 IN 30: 30 years: +0 %: 15 mins: Winter	0.01	4.1	1.879
SWMH-006.1	1 IN 30: 30 years: +0 %: 15 mins: Winter	0.01	2.9	1.325
SWMH-006.2	1 IN 30: 30 years: +0 %: 15 mins: Winter	0.01	4.1	1.888
SWHM-007	1 IN 30: 30 years: +0 %: 15 mins: Winter	0.00	1.0	0.477
SWMH-009	1 IN 30: 30 years: +0 %: 15 mins: Winter	0.03	10.1	4.661
SWMH-008	1 IN 30: 30 years: +0 %: 15 mins: Winter	0.01	3.6	1.666
SWMH-003.2	1 IN 30: 30 years: +0 %: 15 mins: Winter	0.04	12.4	5.755
SWMH-003.1	1 IN 30: 30 years: +0 %: 15 mins: Summer	0.04	10.7	4.643

Project: 6369 Donaldson Vets Honley	Date: 29/04/2025	Designed by: MKJW	Checked by: JDM	Approved By: JDM	
Report Details: Type: Junctions Summary Storm Phase: 6369-SW-Drainage_Network	Company Address: JPG Group 5 John Charles Way, Leeds LS12 6QA				



Critical Storm Per Item: Rank By: Max. Resident Volume

Junction	Storm Event	Cover Level (m)	Invert Level (m)	Max. Level (m)	Max. Depth (m)	Max. Inflow (L/s)	Max. Resident Volume (m³)	Max. Flooded Volume (m³)	Max. Outflow (L/s)	Total Discharge Volume (m³)	Status
PI-001	1 IN 30: 30 years: +0 %: 15 mins: Winter	107.9 95	106.6 25	106.83 8	0.213	46.7	1.220	0.000	43.3	23.507	OK
006	1 IN 30: 30 years: +0 %: 15 mins: Winter	107.9 18	106.8 60	106.94 8	0.088	10.9	0.014	0.000	10.5	5.086	OK
004	1 IN 30: 30 years: +0 %: 15 mins: Winter	107.8 61	106.6 55	106.91 5	0.260	48.1	0.294	0.000	46.7	23.556	Surcharged
005	1 IN 30: 30 years: +0 %: 15 mins: Winter	107.8 22	107.0 70	107.11 8	0.048	4.1	0.008	0.000	4.0	1.877	OK
010-FCC	1 IN 30: 30 years: +0 %: 240 mins: Winter	107.7 89	105.3 55	106.40 9	1.054	5.7	6.035	0.000	2.6	65.346	Surcharged
008	1 IN 30: 30 years: +0 %: 15 mins: Winter	107.7 67	106.7 10	106.75 2	0.042	3.6	0.047	0.000	3.4	1.664	OK
003	1 IN 30: 30 years: +0 %: 15 mins: Winter	107.7 31	106.8 09	106.94 0	0.131	22.5	0.148	0.000	19.6	10.394	OK
009	1 IN 30: 30 years: +0 %: 15 mins: Winter	107.7 08	106.5 75	106.70 8	0.133	24.7	0.150	0.000	23.6	11.872	OK
007	1 IN 30: 30 years: +0 %: 15 mins: Winter	107.6 87	106.6 90	106.78 9	0.099	11.5	0.016	0.000	11.1	5.559	OK
100	1 IN 30: 30 years: +0 %: 15 mins: Winter	107.4 27	105.7 75	105.80 4	0.029	2.6	0.033	0.000	2.6	3.332	OK
001	1 IN 30: 30 years: +0 %: 240 mins: Winter	108.1 10	106.0 10	106.40 9	0.399	2.0	2.285	0.000	0.4	5.265	OK
SWMH-002	1 IN 30: 30 years: +0 %: 240 mins: Winter	108.7 14	105.9 70	106.40 9	0.439	6.3	4.469	0.000	1.2	24.703	OK
Simple Junction (3)	1 IN 30: 30 years: +0 %: 15 mins: Summer		105.6 83	105.71 0	0.027	2.6			2.6	3.252	OK
Simple Junction	1 IN 30: 30 years: +0 %: 15 mins: Summer		105.9 19	106.17 9	0.260	45.2			4.3	16.311	OK

Project: 6369 Donaldson Vets Honley	Date: 29/04/2025	Designed by: MKJW		Checked by: JDM	Approved By: JDM	
Report Details: Type: Connections Summary Storm Phase: 6369-SW-Drainage_Network	Company Address: JPG Group 5 John Charles Way, Leeds LS12 6QA					



Critical Storm Per Item: Rank By: Max. Flow

Connection	Storm Event	Connection Type	From	To	Upstream Cover Level (m)	Max. US Water Level (m)	Max. Flow Depth (m)	Discharge Volume (m³)	Max. Velocity (m/s)	Flow / Capacity	Max. Flow (L/s)	Status
2.001	1 IN 30: 30 years: +0 %: 15 mins: Winter	Pipe	004	PI-001	107.861	106.915	0.225	23.556	1.2	1.1	46.7	Surcharged
2.000	1 IN 30: 30 years: +0 %: 15 mins: Summer	Pipe	003	004	107.731	106.931	0.187	9.773	0.6	0.46	19.7	OK
1.002	1 IN 30: 30 years: +0 %: 15 mins: Winter	Pipe	010-FCC	100	107.789	106.202	0.034	3.391	0.7	0.06	2.6	Surcharged
EX'G	1 IN 30: 30 years: +0 %: 15 mins: Winter	Pipe	100	Simple Junction (3)	107.427	105.804	0.028	3.332	0.9	0.03	2.6	OK
3.003	1 IN 30: 30 years: +0 %: 15 mins: Winter	Pipe	009	010-FCC	107.708	106.708	0.125	11.872	1.0	0.55	23.6	OK
3.000	1 IN 30: 30 years: +0 %: 15 mins: Winter	Pipe	005	006	107.822	107.118	0.068	1.877	0.5	0.22	4.0	OK
3.001	1 IN 30: 30 years: +0 %: 15 mins: Winter	Pipe	006	007	107.918	106.948	0.094	5.086	0.9	0.59	10.5	OK
4.000	1 IN 30: 30 years: +0 %: 15 mins: Winter	Pipe	008	009	107.767	106.752	0.087	1.664	0.2	0.08	3.4	OK
3.002	1 IN 30: 30 years: +0 %: 15 mins: Winter	Pipe	007	009	107.687	106.789	0.093	5.559	1.0	0.64	11.1	OK
1.000	1 IN 30: 30 years: +0 %: 15 mins: Summer	Pipe	001	SWMH-002	108.110	106.180	0.191	0.000	0.0	0	3.0	OK
1.001	1 IN 30: 30 years: +0 %: 15 mins: Summer	Pipe	SWMH-002	Simple Junction	108.714	106.181	0.236	0.000	0.0	0	4.3	OK
1.001 (1)	1 IN 30: 30 years: +0 %: 30 mins: Winter	Pipe	Simple Junction	010-FCC	108.302	106.271	0.384	4.543	0.4	0.01	9.6	OK
2.002	1 IN 30: 30 years: +0 %: 15 mins: Winter	Pipe	PI-001	Simple Junction	107.995	106.838	0.194	23.507	1.2	0.96	43.3	OK

Project: 6369 Donaldson Vets Honley	Date: 29/04/2025			
	Designed by: MKJW	Checked by: JDM	Approved By: JDM	
Report Details: Type: Inflows Storm Phase: 6369-SW-Drainage_Network	Company Address: JPG Group 5 John Charles Way, Leeds LS12 6QA			



SWMH-004.1

Type : Catchment Area

Area (ha)	0.039
-----------	-------

Dynamic Sizing

Runoff Method	Time of Concentration
Summer Volumetric Runoff	0.750
Winter Volumetric Runoff	0.840
Time of Concentration (mins)	5
Percentage Impervious (%)	100



SWMH-004.2

Type : Catchment Area

Area (ha)	0.054
-----------	-------

Dynamic Sizing

Runoff Method	Time of Concentration
Summer Volumetric Runoff	0.750
Winter Volumetric Runoff	0.840
Time of Concentration (mins)	5
Percentage Impervious (%)	100



SWMH-005

Type : Catchment Area

Area (ha)	0.013
-----------	-------

Dynamic Sizing

Runoff Method	Time of Concentration
Summer Volumetric Runoff	0.750
Winter Volumetric Runoff	0.840
Time of Concentration (mins)	5
Percentage Impervious (%)	100

Project: 6369 Donaldson Vets Honley	Date: 29/04/2025		
Report Details: Type: Inflows Storm Phase: 6369-SW-Drainage_Network	Designed by: MKJW	Checked by: JDM	Approved By: JDM
	Company Address: JPG Group 5 John Charles Way, Leeds LS12 6QA		



SWMH-006.1

Type : Catchment Area

Area (ha)	0.009
-----------	-------

Dynamic Sizing

Runoff Method	Time of Concentration
Summer Volumetric Runoff	0.750
Winter Volumetric Runoff	0.840
Time of Concentration (mins)	5
Percentage Impervious (%)	100



SWMH-006.2

Type : Catchment Area

Area (ha)	0.013
-----------	-------

Dynamic Sizing

Runoff Method	Time of Concentration
Summer Volumetric Runoff	0.750
Winter Volumetric Runoff	0.840
Time of Concentration (mins)	5
Percentage Impervious (%)	100



SWHM-007

Type : Catchment Area

Area (ha)	0.003
-----------	-------

Dynamic Sizing

Runoff Method	Time of Concentration
Summer Volumetric Runoff	0.750
Winter Volumetric Runoff	0.840
Time of Concentration (mins)	5
Percentage Impervious (%)	100

Project: 6369 Donaldson Vets Honley	Date: 29/04/2025	Designed by: MKJW	Checked by: JDM	Approved By: JDM	
Report Details: Type: Inflows Storm Phase: 6369-SW-Drainage_Network	Company Address: JPG Group 5 John Charles Way, Leeds LS12 6QA				



SWMH-009

Type : Catchment Area

Area (ha)	0.033
-----------	-------

Dynamic Sizing

Runoff Method	Time of Concentration
Summer Volumetric Runoff	0.750
Winter Volumetric Runoff	0.840
Time of Concentration (mins)	5
Percentage Impervious (%)	100



SWMH-008

Type : Catchment Area

Area (ha)	0.012
-----------	-------

Dynamic Sizing

Runoff Method	Time of Concentration
Summer Volumetric Runoff	0.750
Winter Volumetric Runoff	0.840
Time of Concentration (mins)	5
Percentage Impervious (%)	100



SWMH-003.2

Type : Catchment Area

Area (ha)	0.041
-----------	-------

Dynamic Sizing

Runoff Method	Time of Concentration
Summer Volumetric Runoff	0.750
Winter Volumetric Runoff	0.840
Time of Concentration (mins)	5
Percentage Impervious (%)	100

Project: 6369 Donaldson Vets Honley	Date: 29/04/2025	Designed by: MKJW	Checked by: JDM	Approved By: JDM	
Report Details: Type: Inflows Storm Phase: 6369-SW-Drainage_Network	Company Address: JPG Group 5 John Charles Way, Leeds LS12 6QA				



SWMH-003.1

Type : Catchment Area

Area (ha)	0.037
-----------	-------

Dynamic Sizing

Runoff Method	Time of Concentration
Summer Volumetric Runoff	0.750
Winter Volumetric Runoff	0.750
Time of Concentration (mins)	5
Percentage Impervious (%)	100

Project: 6369 Donaldson Vets Honley		Date: 29/04/2025		
Report Details: Type: Junctions Storm Phase: 6369-SW-Drainage_Network		Designed by: MKJW	Checked by: JDM	Approved By: JDM
		Company Address: JPG Group 5 John Charles Way, Leeds LS12 6QA		



Name	Junction Type	Easting (m)	Northing (m)	Cover Level (m)	Depth (m)	Invert Level (m)	Sump Depth (m)	Chamber Shape
PI-001	Manhole	414178.235	411795.272	107.995	1.370	106.625	0.000	Circular
006	Manhole	414175.550	411836.615	107.918	1.058	106.860	0.000	Circular
004	Manhole	414175.714	411799.000	107.861	1.206	106.655	0.000	Circular
005	Manhole	414192.965	411848.351	107.822	0.752	107.070	0.000	Circular
010-FCC	Manhole	414156.729	411819.347	107.789	2.434	105.355	0.500	Circular
008	Manhole	414172.956	411806.432	107.767	1.057	106.710	0.000	Circular
003	Manhole	414195.277	411811.095	107.731	0.923	106.809	0.000	Circular
009	Manhole	414161.993	411823.160	107.708	1.133	106.575	0.000	Circular
007	Manhole	414161.330	411827.299	107.687	0.997	106.690	0.000	Circular
100	Manhole	414144.737	411818.913	107.427	1.653	105.775	0.000	Circular
001	Manhole	414206.025	411783.208	108.110	2.100	106.010	0.000	Circular
SWMH-002	Manhole	414189.427	411772.049	108.714	2.744	105.970	0.000	Circular
Simple Junction (3)	Simple Junction	414143.265	411822.289					
Simple Junction	Simple Junction	414174.869	411793.108					

Name	Diameter (m)	Part Family	Lock
PI-001	2.700	Type B	All
006	0.450	PPIC	All
004	1.200	Type E	All
005	0.450	PPIC	All
010-FCC	2.700	Type B	All
008	1.200	Type E	All
003	1.200	Type E	All
009	1.200	Type E	All
007	0.450	PPIC	All
100	1.200	Type E	All
001	2.700	Type B	All
SWMH-002	3.600		All
Simple Junction (3)			
Simple Junction			

Project: 6369 Donaldson Vets Honley	Date: 29/04/2025	Designed by: MKJW	Checked by: JDM	Approved By: JDM	
Report Details: Type: Junctions Storm Phase: 6369-SW-Drainage_Network	Company Address: JPG Group 5 John Charles Way, Leeds LS12 6QA				

Outlets

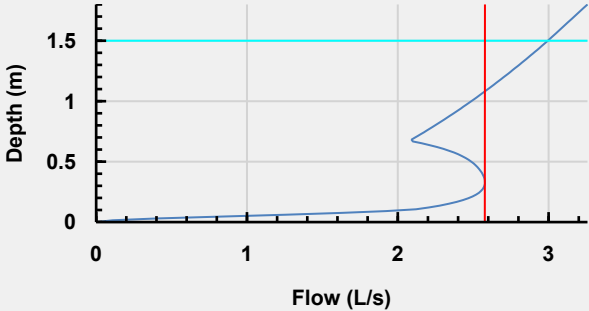
Junction	Outlet Name	Outgoing Connection	Outlet Type	
PI-001	Outlet	2.002	Free Discharge	
006	Outlet	3.001	Free Discharge	
004	Outlet	2.001	Free Discharge	
005	Outlet	3.000	Free Discharge	
010-FCC	Outlet	1.002	Hydro-Brake®	
	Invert Level (m)	105.855		
	Design Depth (m)	1.500		
	Design Flow (L/s)	3.0		
	Objective	Minimise Upstream Storage Requirements		
	Application	Surface Water Only		
	Sump Available	<input checked="" type="checkbox"/>		
	Unit Reference	SHE-0075-3000-1500-3000		
				
	008	Outlet	4.000	Free Discharge
003	Outlet	2.000	Free Discharge	
009	Outlet	3.003	Free Discharge	
007	Outlet	3.002	Free Discharge	
100	Outlet	EX'G	Free Discharge	
001	Outlet	1.000	Free Discharge	
SWMH-002	Outlet	1.001	Free Discharge	
Simple Junction	Outlet	1.001 (1)	Free Discharge	

Project: 6369 Donaldson Vets Honley		Date: 29/04/2025		
Report Details: Type: Connections Storm Phase: 6369-SW-Drainage_Network		Designed by: MKJW	Checked by: JDM	Approved By: JDM
		Company Address: JPG Group 5 John Charles Way, Leeds LS12 6QA		



Name	Length (m)	Connection Type	Slope (1:X)	Manning's n	Colebrook-White Roughness (mm)	Diameter / Base Width (mm)	Upstream Cover Level (m)	Upstream Invert Level (m)
2.001	4.500	Pipe	149.925		0.6	225	107.861	106.655
2.000	23.000	Pipe	149.561		0.6	225	107.731	106.809
1.002	12.000	Pipe	149.925		0.6	225	107.789	105.855
EX'G	3.683	Pipe	40.000		0.6	225	107.427	105.775
3.003	6.500	Pipe	144.444		0.6	225	107.708	106.575
3.000	21.000	Pipe	100.000		0.6	150	107.822	107.070
3.001	17.000	Pipe	100.000		0.6	150	107.918	106.860
4.000	20.000	Pipe	148.148		0.6	225	107.767	106.710
3.002	4.192	Pipe	104.789		0.6	150	107.687	106.690
1.000	20.000	Pipe	500.000		0.6	900	108.110	106.010
1.001	25.601	Pipe	500.000		0.6	900	108.714	105.970
1.001 (1)	31.899	Pipe	500.000		0.6	900	108.302	105.919
2.002	4.002	Pipe	133.408		0.6	225	107.995	106.625

Name	Downstream Cover Level (m)	Downstream Invert Level (m)	Part Family	Lock	Flow Restriction (L/s)	Culvert Type	Culvert Entrance
2.001	107.995	106.625	Clay Pipe SI	All		(None)	(None)
2.000	107.861	106.655	Clay Pipe SI	All		(None)	(None)
1.002	107.427	105.775	Clay Pipe SI	All	3.3	(None)	(None)
EX'G	105.908	105.683	Clay Pipe SI	All		(None)	(None)
3.003	107.789	106.530	Clay Pipe SI	All		(None)	(None)
3.000	107.918	106.860	Clay Pipe SI	All		(None)	(None)
3.001	107.687	106.690	Clay Pipe SI	All		(None)	(None)
4.000	107.708	106.575	Clay Pipe SI	All		(None)	(None)
3.002	107.708	106.650	Clay Pipe SI	All		(None)	(None)
1.000	108.714	105.970	Concrete Pipe SI	All		(None)	(None)
1.001	108.302	105.919	Concrete Pipe SI	All		(None)	(None)
1.001 (1)	107.789	105.855	Concrete Pipe SI	All		(None)	(None)
2.002	108.302	106.595		All		(None)	(None)

Project: 6369 Donaldson Vets Honley	Date: 29/04/2025		
	Designed by: MKJW	Checked by: JDM	Approved By: JDM
Report Details: Type: Network Design Criteria Storm Phase: 6369-SW-Drainage_Network	Company Address: JPG Group 5 John Charles Way, Leeds LS12 6QA		

Flow Options

Peak Flow Calculation	(UK) Modified Rational Method
Min. Time of Entry (mins)	5
Max. Travel Time (mins)	30

Pipe Options

Lock Slope Options	None
Design Options	Minimise Excavation
Design Level	Level Soffits
Min. Cover Depth (m)	1.200
Min. Slope (1:X)	500.00
Max. Slope (1:X)	40.00
Min. Velocity (m/s)	1.0
Max. Velocity (m/s)	3.0
Use Flow Restriction	<input type="checkbox"/>
Reduce Channel Depths	<input type="checkbox"/>

Manhole Options

Apply Offset	<input type="checkbox"/>
--------------	--------------------------

Project: 6369 Donaldson Vets Honley	Date: 29/04/2025		
	Designed by: MKJW	Checked by: JDM	Approved By: JDM
Report Details: Type: Outfall Details Storm Phase: 6369-SW-Drainage_Network	Company Address: JPG Group 5 John Charles Way, Leeds LS12 6QA		



Outfalls

Outfall	Outfall Type	Gated	Fixed Surcharged Level (m)	Level Curve
Simple Junction (3)	Free Discharge			

Project: 6369 Donaldson Vets Honley	Date: 29/04/2025		
	Designed by: MKJW	Checked by: JDM	Approved By: JDM
Report Title: Rainfall Analysis Criteria	Company Address: JPG Group 5 John Charles Way, Leeds LS12 6QA		



Runoff Type	Dynamic
Output Interval (mins)	5
Time Step	Default
Urban Creep	Apply Global Value
Urban Creep Global Value (%)	0
Junction Flood Risk Margin (mm)	300
Prefill Manhole Sumps	<input type="checkbox"/>
Perform No Discharge Analysis	<input type="checkbox"/>

Project: 6369 Donaldson Vets Honley	Date: 29/04/2025	Designed by: MKJW	Checked by: JDM	Approved By: JDM	
Report Details: Type: Inflows Summary Storm Phase: 6369-SW-Drainage_Network	Company Address: JPG Group 5 John Charles Way, Leeds LS12 6QA				



Critical Storm Per Item: Rank By: Max. Inflow

Inflow	Storm Event	Inflow Area (ha)	Max. Inflow (L/s)	Total Inflow Volume (m³)
SWMH-004.1	1 IN 100 + 45%CC: 100 years: +45 %: 15 mins: Winter	0.04	22.4	10.381
SWMH-004.2	1 IN 100 + 45%CC: 100 years: +45 %: 15 mins: Winter	0.05	30.9	14.336
SWMH-005	1 IN 100 + 45%CC: 100 years: +45 %: 15 mins: Winter	0.01	7.6	3.514
SWMH-006.1	1 IN 100 + 45%CC: 100 years: +45 %: 15 mins: Winter	0.01	5.4	2.486
SWMH-006.2	1 IN 100 + 45%CC: 100 years: +45 %: 15 mins: Winter	0.01	7.6	3.544
SWHM-007	1 IN 100 + 45%CC: 100 years: +45 %: 15 mins: Winter	0.00	1.9	0.894
SWMH-009	1 IN 100 + 45%CC: 100 years: +45 %: 15 mins: Winter	0.03	18.9	8.741
SWMH-008	1 IN 100 + 45%CC: 100 years: +45 %: 15 mins: Winter	0.01	6.7	3.122
SWMH-003.2	1 IN 100 + 45%CC: 100 years: +45 %: 15 mins: Winter	0.04	23.3	10.789
SWMH-003.1	1 IN 100 + 45%CC: 100 years: +45 %: 15 mins: Summer	0.04	20.0	8.702

Project: 6369 Donaldson Vets Honley	Date: 29/04/2025	Designed by: MKJW	Checked by: JDM	Approved By: JDM	
Report Details: Type: Junctions Summary Storm Phase: 6369-SW-Drainage_Network	Company Address: JPG Group 5 John Charles Way, Leeds LS12 6QA				



Critical Storm Per Item: Rank By: Max. Resident Volume

Junction	Storm Event	Cover Level (m)	Invert Level (m)	Max. Level (m)	Max. Depth (m)	Max. Inflow (L/s)	Max. Resident Volume (m³)	Max. Flooded Volume (m³)	Max. Outflow (L/s)	Total Discharge Volume (m³)	Status
PI-001	1 IN 100 + 45%CC: 100 years: +45 %: 360 mins: Winter	107.9 95	106.6 25	107.33 0	0.705	15.3	4.038	0.000	15.3	131.385	Surcharged
006	1 IN 100 + 45%CC: 100 years: +45 %: 360 mins: Winter	107.9 18	106.8 60	107.33 0	0.470	3.3	0.075	0.000	3.3	28.379	Surcharged
004	1 IN 100 + 45%CC: 100 years: +45 %: 360 mins: Winter	107.8 61	106.6 55	107.33 0	0.675	15.3	0.764	0.000	15.3	131.430	Surcharged
005	1 IN 100 + 45%CC: 100 years: +45 %: 360 mins: Winter	107.8 22	107.0 70	107.33 0	0.260	1.2	0.041	0.000	1.2	10.465	Surcharged
010-FCC	1 IN 100 + 45%CC: 100 years: +45 %: 360 mins: Winter	107.7 89	105.3 55	107.33 0	1.975	7.7	11.309	0.000	2.9	104.757	Surcharged
008	1 IN 100 + 45%CC: 100 years: +45 %: 360 mins: Winter	107.7 67	106.7 10	107.33 0	0.620	1.1	0.701	0.000	1.1	9.296	Surcharged
003	1 IN 100 + 45%CC: 100 years: +45 %: 15 mins: Winter	107.7 31	106.8 09	107.43 3	0.624	42.1	0.706	0.000	38.7	19.494	Flood Risk
009	1 IN 100 + 45%CC: 100 years: +45 %: 360 mins: Winter	107.7 08	106.5 75	107.33 0	0.755	7.7	0.854	0.000	7.7	66.180	Surcharged
007	1 IN 100 + 45%CC: 100 years: +45 %: 360 mins: Winter	107.6 87	106.6 90	107.33 0	0.640	3.6	0.102	0.000	3.6	30.998	Surcharged
100	1 IN 100 + 45%CC: 100 years: +45 %: 360 mins: Winter	107.4 27	105.7 75	105.80 6	0.031	2.9	0.035	0.000	2.9	101.454	OK
001	1 IN 100 + 45%CC: 100 years: +45 %: 360 mins: Winter	108.1 10	106.0 10	107.33 0	1.320	3.2	7.559	0.000	0.5	8.583	Surcharged
SWMH-002	1 IN 100 + 45%CC: 100 years: +45 %: 360 mins: Winter	108.7 14	105.9 70	107.33 0	1.360	9.9	13.844	0.000	1.3	45.970	Surcharged
Simple Junction (3)	1 IN 100 + 45%CC: 100 years: +45 %: 15 mins: Summer		105.6 83	105.71 0	0.027	2.6			2.6	3.459	OK
Simple Junction	1 IN 100 + 45%CC: 100 years: +45 %: 15 mins: Summer		105.9 19	106.35 7	0.439	96.5			9.7	28.023	OK

Project: 6369 Donaldson Vets Honley	Date: 29/04/2025	Designed by: MKJW		Checked by: JDM	Approved By: JDM	
Report Details: Type: Connections Summary Storm Phase: 6369-SW-Drainage_Network	Company Address: JPG Group 5 John Charles Way, Leeds LS12 6QA					



Critical Storm Per Item: Rank By: Max. Flow

Connection	Storm Event	Connection Type	From	To	Upstream Cover Level (m)	Max. US Water Level (m)	Max. Flow Depth (m)	Discharge Volume (m³)	Max. Velocity (m/s)	Flow / Capacity	Max. Flow (L/s)	Status
2.001	1 IN 100 + 45%CC: 100 years: +45 %: 15 mins: Winter	Pipe	004	PI-001	107.861	107.281	0.225	44.189	2.2	2.11	89.4	Surcharged
2.000	1 IN 100 + 45%CC: 100 years: +45 %: 15 mins: Winter	Pipe	003	004	107.731	107.433	0.225	19.494	1.0	0.91	38.7	Flood Risk
1.002	1 IN 100 + 45%CC: 100 years: +45 %: 360 mins: Winter	Pipe	010-FCC	100	107.789	107.330	0.036	101.505	0.7	0.07	2.9	Surcharged
EX'G	1 IN 100 + 45%CC: 100 years: +45 %: 360 mins: Winter	Pipe	100	Simple Junction (3)	107.427	105.806	0.030	101.454	0.9	0.04	2.9	OK
3.003	1 IN 100 + 45%CC: 100 years: +45 %: 15 mins: Winter	Pipe	009	010-FCC	107.708	106.782	0.189	22.273	1.2	0.97	41.7	OK
3.000	1 IN 100 + 45%CC: 100 years: +45 %: 15 mins: Winter	Pipe	005	006	107.822	107.137	0.141	3.508	0.4	0.42	7.4	OK
3.001	1 IN 100 + 45%CC: 100 years: +45 %: 15 mins: Winter	Pipe	006	007	107.918	107.075	0.150	9.535	1.0	1.03	18.4	Surcharged
4.000	1 IN 100 + 45%CC: 100 years: +45 %: 15 mins: Winter	Pipe	008	009	107.767	106.790	0.143	3.119	0.2	0.13	5.5	OK
3.002	1 IN 100 + 45%CC: 100 years: +45 %: 15 mins: Winter	Pipe	007	009	107.687	106.873	0.150	10.426	1.1	1.12	19.4	Surcharged
1.000	1 IN 100 + 45%CC: 100 years: +45 %: 360 mins: Winter	Pipe	001	SWMH-002	108.110	107.330	0.900	0.000	0.0	0	0.5	Surcharged
1.001	1 IN 100 + 45%CC: 100 years: +45 %: 360 mins: Winter	Pipe	SWMH-002	Simple Junction	108.714	107.330	0.900	0.000	0.0	0	1.3	Surcharged

Project: 6369 Donaldson Vets Honley		Date: 29/04/2025					
Report Details: Type: Connections Summary Storm Phase: 6369-SW-Drainage_Network		Designed by: MKJW	Checked by: JDM	Approved By: JDM			
		Company Address: JPG Group 5 John Charles Way, Leeds LS12 6QA					

1.001 (1)	1 IN 100 + 45%CC: 100 years: +45 %: 15 mins: Winter	Pipe	Simple Junction	010-FCC	108.302	106.397	0.510	1.157	0.5	0.01	13.0	OK
2.002	1 IN 100 + 45%CC: 100 years: +45 %: 15 mins: Winter	Pipe	PI-001	Simple Junction	107.995	107.026	0.225	44.145	2.1	1.85	83.3	Surcharged



Appendix K Impermeable Area Plan

DO NOT SCALE (A1)

NOTES

GENERAL NOTES

1. ALL MATERIALS AND WORKMANSHIP IS TO COMPLY WITH JPG CONSULTANTS STANDARD SPECIFICATION & ALL RELEVANT BRITISH & EUROPEAN STANDARDS.
2. THIS DRAWING IS TO BE READ IN CONJUNCTION WITH ALL RELEVANT ARCHITECTS, M & E CONSULTANTS AND JPG CONSULTANTS DRAWINGS.
3. ANY DISCREPANCIES SHOULD BE REPORTED TO THE ENGINEER IMMEDIATELY SO THAT CLARIFICATION CAN BE SOUGHT PRIOR TO COMMENCEMENT OF WORKS.

LEGEND

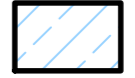
-  DENOTES PROPOSED BUILDINGS
-  DENOTES PROPOSED EXTERNALS

IMPERMEABLE AREAS

BUILDINGS = 713.771m²/0.0714Ha
 EXTERNALS = 1835.738m²/0.184Ha
 TOTAL = 2549.509m²/0.255Ha

**Crossley
 1-8, 11**

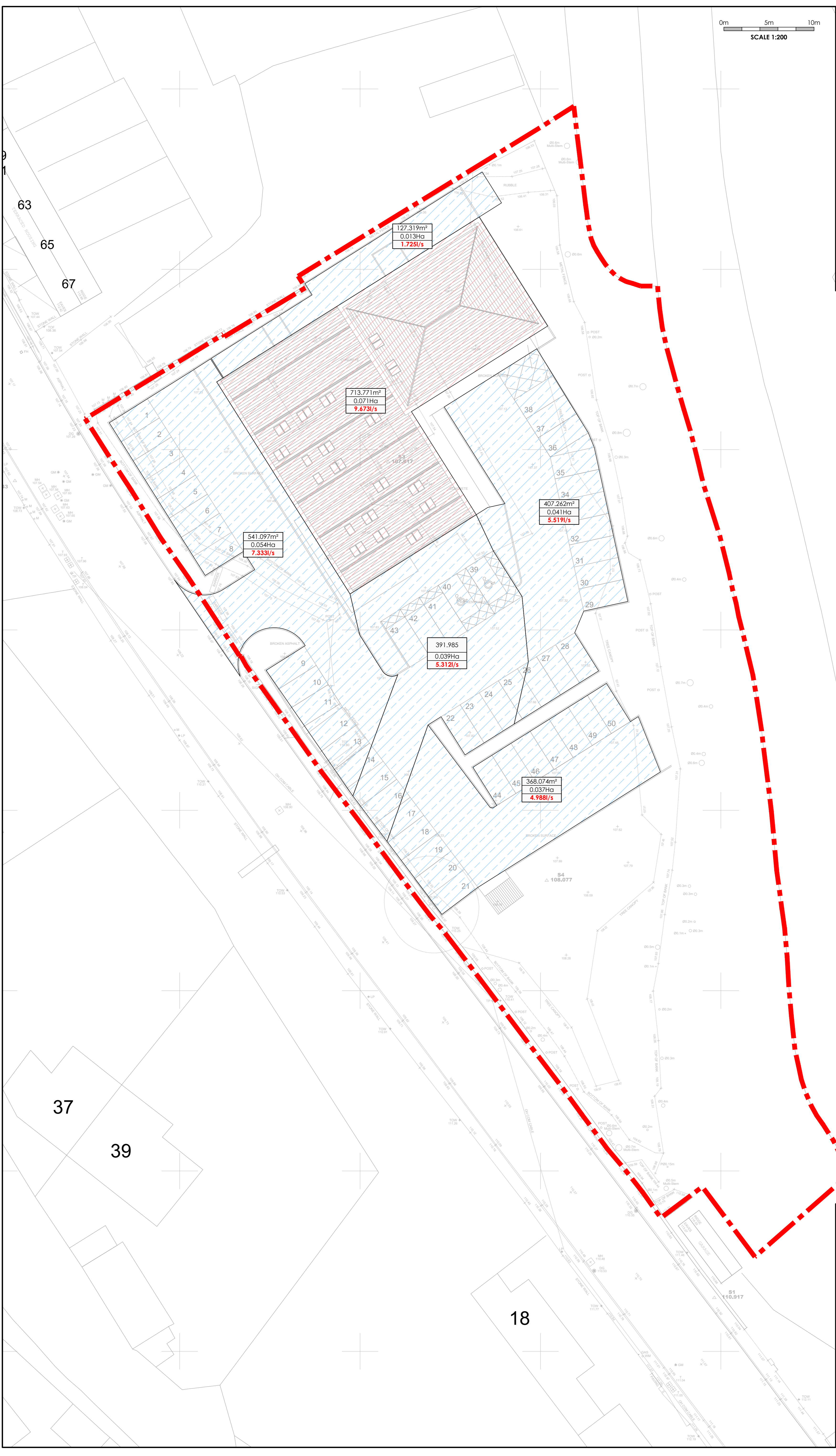

P02	REVISED TO LATEST LAYOUT	29.04.25	RMR	LSG
P01	ISSUED FOR INFORMATION	28.05.24	RMR	SMS
REV	DESCRIPTION	DATE	CHK	BY

Project
 DONALDSON'S VETS
 HONELY

Drawing Title
 IMPERMEABLE AREA PLAN

INFORMATION





Appendix L SuDs Manual – SuDs Mitigation Indices



The SuDS Manual - Table 26.2 Pollution hazard indices for different land use classifications

Category	Land use	Pollution hazard level	Total suspended solids (TSS)	Metals	Hydrocarbons
1	Residential roofs.	Very low	0.2	0.2	0.05
2	Other roofs (typically commercial/industrial roofs).	Low	0.3	0.2	0.05
3	Individual property driveways, residential car parks, low traffic roads (eg cul de sacs, homezones and general access roads) and non-residential car parking with infrequent change (eg schools, offices) ie < 300 traffic movements/day.	Low	0.5	0.4	0.4
4	Commercial yard and delivery areas, non-residential car parking with frequent change (eg hospitals, retail), all roads except low traffic roads and trunk roads/motorways.	Medium	0.7	0.6	0.7
5	Sites with heavy pollution (eg haulage yards, lorry parks, highly frequented lorry approaches to industrial estates, waste sites), sites where chemicals and fuels (other than domestic fuel oil) are to be delivered, handled, stored, used or manufactured; industrial sites; trunk roads and motorways.	High	0.8	0.8	0.9

Summary	
Category	3
Pollution hazard level	Low
Total suspended solids (TSS)	0.5
Metals	0.4
Hydrocarbons	0.4





The SuDS Manual - Table 26.3 Indicative SuDS mitigation indices for discharges to surface waters

Type of SuDS component	Mitigation indices		
	Total suspended solids (TSS)	Metals	Hydrocarbons
Filter strip	0.4	0.4	0.5
Filter drain	0.4	0.4	0.4
Swale	0.5	0.6	0.6
Bioretention system	0.8	0.8	0.8
Permeable pavement	0.7	0.6	0.7
Detention basin	0.5	0.5	0.6
Pond	0.7	0.7	0.5
Wetland	0.8	0.8	0.8
Bypass Petrol Interceptor	0.8	0.6	0.9
Proprietary treatment system 2	0	0	0
Proprietary treatment system 3	0	0	0
None	0	0	0

SuDS components	Mitigation indices		
	Total suspended solids (TSS)	Metals	Hydrocarbons
(1) Filter drain	0.4	0.4	0.4
(2) Bypass Petrol Interceptor	0.8	0.6	0.9
(3) None	0	0	0
Total mitigation indices	0.8	0.7	0.85
Required mitigation indices	0.5	0.4	0.4

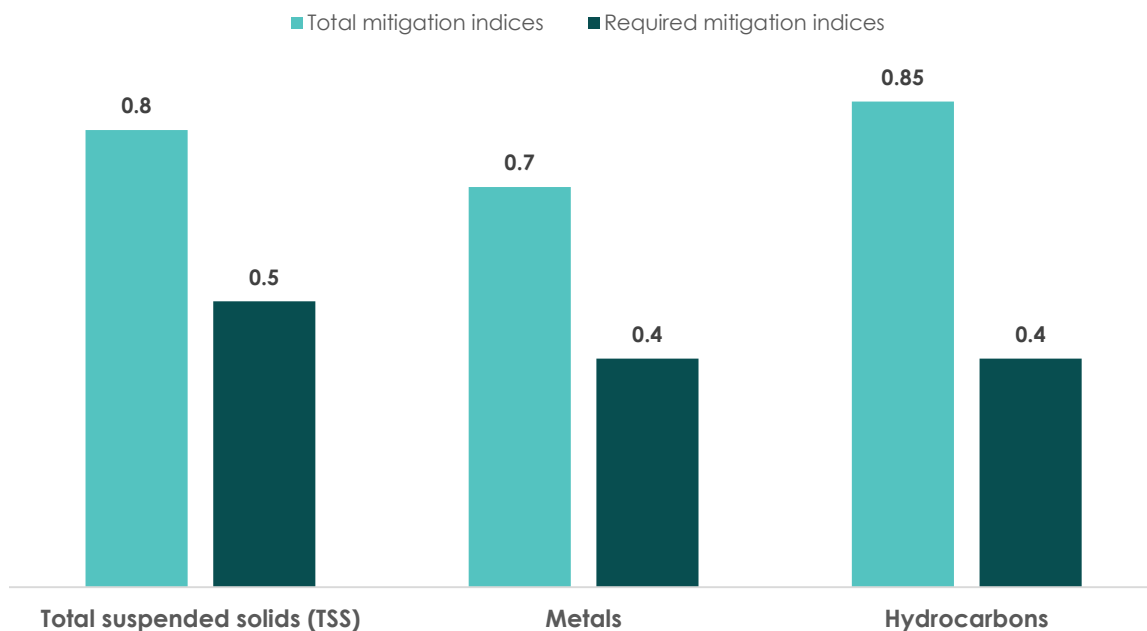



Appendix M Foul Water Strategy

DO NOT SCALE (A1)

NOTES

GENERAL NOTES

1. ALL MATERIALS AND WORKMANSHIP IS TO COMPLY WITH JPG CONSULTANTS STANDARD SPECIFICATION & ALL RELEVANT BRITISH & EUROPEAN STANDARDS.
2. THIS DRAWING IS TO BE READ IN CONJUNCTION WITH ALL RELEVANT ARCHITECTS, M & E CONSULTANTS AND JPG CONSULTANTS DRAWINGS.
3. ANY DISCREPANCIES SHOULD BE REPORTED TO THE ENGINEER IMMEDIATELY SO THAT CLARIFICATION CAN BE SOUGHT PRIOR TO COMMENCEMENT OF WORKS.

DRAINAGE NOTES

1. ALL BUILDING DRAINAGE WORKS SHALL BE CARRIED OUT IN ACCORDANCE WITH BS EN 752:2008 DRAINAGE AND SEWER SYSTEMS OUTSIDE BUILDINGS, THE CURRENT BUILDING REGULATIONS AND THE LOCAL AUTHORITY BUILDING CONTROL SPECIFICATIONS AND REQUIREMENTS.
2. ANY DRAINAGE TO BE PUT FORWARD FOR ADOPTION EITHER WITHIN THE SITE OR OUTSIDE SHALL BE CONSTRUCTED TO SEWERS FOR ADOPTION LATEST EDITION AND ANY SPECIFIC REQUIREMENTS OF THE ADOPTING SEWERAGE/WATER AUTHORITY.
3. THE LOCATION, SIZE AND DEPTH OF ALL EXISTING DRAINS/SEWERS AND SERVICES SHALL BE ESTABLISHED BY THE CONTRACTOR PRIOR TO THE COMMENCEMENT OF WORKS ON SITE. ANY DISCREPANCIES FROM THE INFORMATION INDICATED ON THESE DRAWINGS SHALL IMMEDIATELY BE BROUGHT TO THE ATTENTION OF THE ENGINEER.
4. THE CONTRACTOR SHALL IMMEDIATELY NOTIFY THE ENGINEER SHOULD ANY EXISTING LIVE DRAINAGE BE FOUND WITHIN THE SITE BOUNDARY SERVING ADJACENT PROPERTIES.
5. ALL EXISTING DRAINAGE WITHIN THE SITE NOT REQUIRED FOR THE NEW DEVELOPMENT SHALL BE ABANDONED. DRAINS AND SEWERS LESS THAN 1.500m DEEP WHICH ARE IN OPEN GROUND SHOULD AS FAR AS IS PRACTICABLE BE FULLY REMOVED. ALL OTHER PIPES SHOULD BE SEALED AT BOTH ENDS AND AT ANY POINT OF CONNECTION, AND BE GROUT FILLED TO ENSURE THAT RATS CANNOT GAIN ACCESS. LARGER PIPES 225Ø OR ABOVE SHOULD BE GROUT FILLED TO PREVENT SUBSIDENCE OR DAMAGE TO BUILDINGS OR SERVICES IN THE EVENT OF COLLAPSE.
6. THE CONTRACTOR SHALL ALLOW FOR THE PROTECTION, TEMPORARY AND PERMANENT SUPPORT AND DIVERSION WORKS AS NECESSARY, TO ALL EXISTING SERVICES TO THE SATISFACTION OF THE UTILITY COMPANIES.
7. THE CONTRACTOR SHALL ALLOW FOR DEALING WITH SURFACE WATER RUN OFF INTO EXCAVATIONS AND FROM GROUNDWATER BY MEANS OF SUMPS, PUMPING AND DE WATERING AS APPROPRIATE, IN ORDER TO KEEP THE EXCAVATION AS REASONABLY DRY AS POSSIBLE DURING THE CONSTRUCTION OF THE WORKS.
8. THE CONTRACTOR SHALL TAKE ALL NECESSARY SAFETY PRECAUTIONS IN LINE WITH CURRENT LEGISLATION WHEN WORKING IN/NEAR CONFINED SPACES, DEEP EXCAVATIONS AND MACHINERY.
9. THE CONTRACTOR SHALL ALLOW FOR OBTAINING ALL APPROVALS FROM THE RELEVANT AUTHORITIES WHEN WORKING IN THE PUBLIC HIGHWAY AND ON THE SEWERAGE SYSTEM.
10. THE CONTRACTOR SHALL SUITABLY PROTECT PEDESTRIANS AND VEHICLES FROM WORKING AREAS.
11. ALL MANHOLE/CHAMBER COVER LEVELS ARE APPROXIMATE AND SHALL BE ADJUSTED ON SITE TO SUIT THE PROPOSED FINISHED LEVELS.
12. ALL PIPES SHALL BE LAID WITH LEVEL SOFFITS AND ALL MANHOLE/INSPECTION CHAMBER INVERT LEVELS SHOWN ARE FOR THE OUT GOING PIPE UNO. ON THE DRAWINGS (NOTE THAT ALL PIPE GRADIENTS INDICATED ON THE DRAWING ARE APPROXIMATE ONLY).
13. ALL PIPE CONNECTION FROM DRAINAGE CHANNELS AND GULLIES SHALL BE 150Ø PIPES AT A MINIMUM GRADIENT OF 1:100 WITH CLASS Z BEDDING UNO, ON THE DRAWING.
14. ALL PIPE CONNECTIONS FROM RWPS TO BE 100Ø AT 1:50 MIN. AND ALL PIPE CONNECTIONS FROM WPCS TO FIRST CHAMBER SHALL BE 100Ø AT 1:40 MIN. WITH CLASS S BEDDING BENEATH THE BUILDING AND CLASS Z UNDER EXTERNALS WHERE COVER IS LESS THAN 1.20m UNO. ON THE DRAWINGS (LOCATION OF RWPS AND WPCS TO BE CONFIRMED BY THE ARCHITECT AND ARE SHOWN INDICATIVELY ONLY).
15. ALL SYPHONIC RWP SYSTEMS TO BE DESIGNED BY OTHERS. PIPEWORK FROM DOWN PIPE TO FIRST MANHOLE TO BE SIZED/ DESIGNED BY SYPHONIC SYSTEM DESIGNER. THE FIRST MANHOLE TO HAVE AN OPEN GRATE COVER SAINT GABAIN WATERWAY 2000 - D400 OR SIMILAR APPROVED.
16. SUITABLY SIZED PETROL INTERCEPTORS MUST COMPLY WITH THE REQUIREMENTS OUTLINE IN PPG3 THESE INCLUDE SILT STORAGE CAPACITY AND HIGH LEVEL HYDROCARBON ALARM WIRED BACK TO A MANNED OFFICE.
17. UPON COMPLETION OF THE DRAINAGE WORKS THE CONTRACTOR SHALL CLEAN ALL DRAIN RUNS BY JETTING AND REMOVE ALL DEBRIS FROM SITE. NO DEBRIS SHALL BE PERMITTED TO ENTER THE PUBLIC SEWER AND/OR WATERCOURSE SYSTEM. ONCE THE DRAINAGE SYSTEM HAS BEEN FULLY CLEANED OUT A CCTV CAMERA CONDITION SURVEY SHALL BE UNDERTAKEN TO ALL CONSTRUCTED DRAINAGE AND SEWER PIPES WITH THE FOOTAGE ISSUED TO THE ENGINEER FOR VIEW. THE AS BUILT INVERT AND COVER LEVELS SHALL BE RECORDED BY THE CONTRACTOR AND PASSED ON TO THE ENGINEER FOR REVIEW.

LEGEND

- - - - - PROPOSED FOUL WATER PIPE
- PROPOSED FOUL WATER MANHOLE
- - - - - EXISTING COMBINED WATER PIPE
- EXISTING COMBINED WATER MANHOLE
- - - - - PROPOSED SITE BOUNDARY

FOUL WATER DESIGN FLOW CALCULATION

USE	L/DAY	AREA m ²	TOTAL L/DAY
OFFICES	750 PER 100m ²	736.986	5527.395
DESIGN FLOW= (6xDWF+10%)			36480.807/Day
DESIGN FW FLOW=			0.422l/s

NOTE
WASTE POINT CONNECTIONS SUBJECT TO DETAILED DESIGN

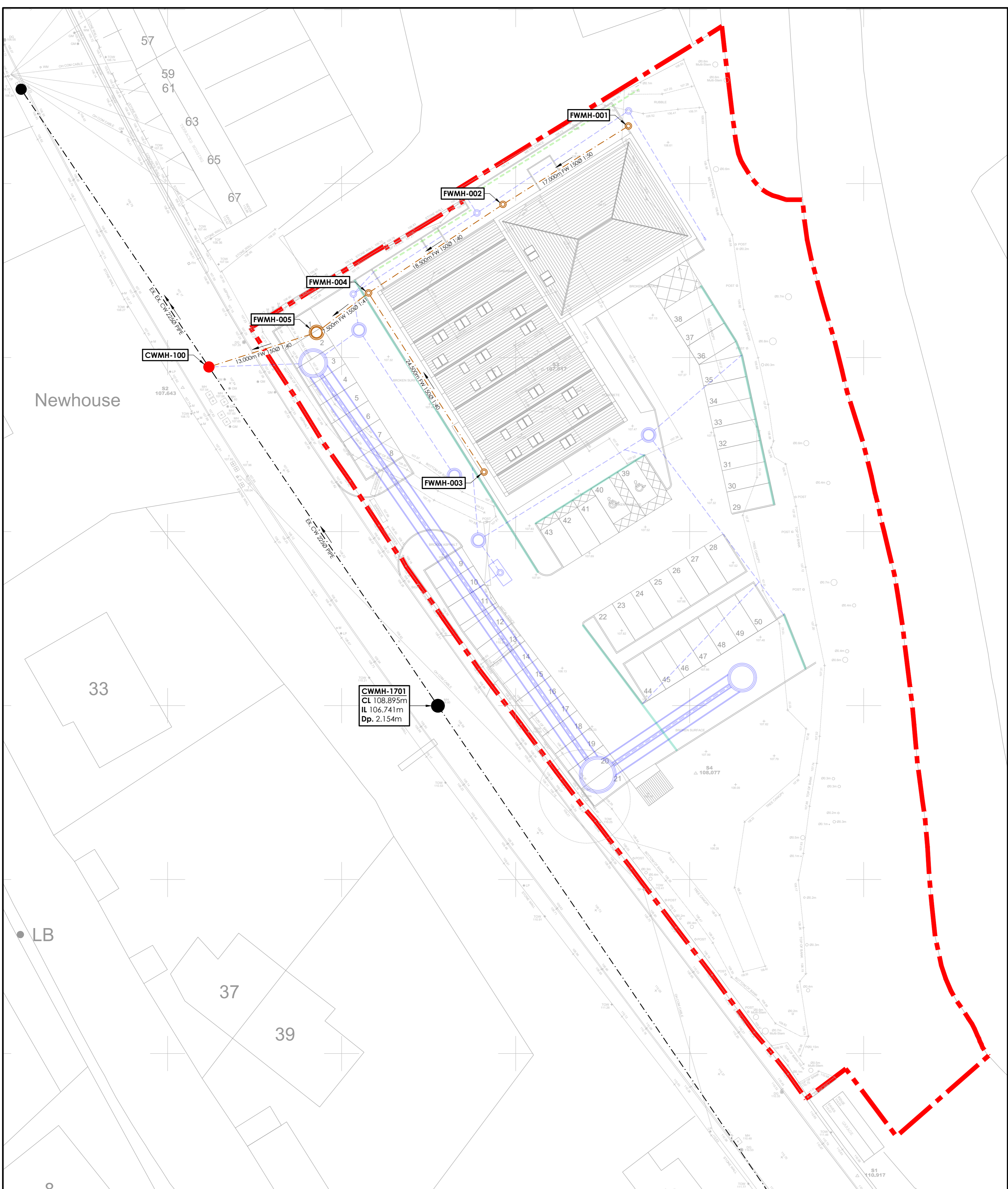
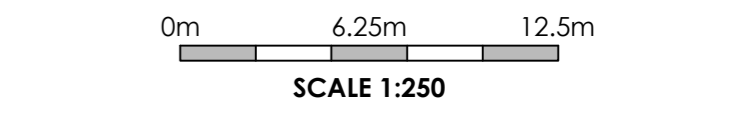

PLAN ON FOUL WATER DRAINAGE
SCALE 1:200

6369-FW-DRAINAGE_NETWORK MANHOLE SCHEDULE										
REF.	COVER LEVEL	INVERT LEVEL	SUMP DEPTH	DEPTH	EASTING	NORTHING	DIAMETER	TYPE	COVER	NOTES
001	107.849m	107.090m - 150Ø OUT	0.000m	0.759m	414192.954	411846.608	450Ø	PPIC	450x450 - CLASS B125	-
002	107.956m	106.750m - 150Ø IN 106.750m - 150Ø OUT	0.000m	1.206m	414178.535	411837.602	450Ø	PPIC	300x300 - CLASS B125	-
003	107.827m	106.898m - 150Ø OUT	0.000m	0.930m	414176.364	411806.836	450Ø	PPIC	450x450 - CLASS B125	-
004	107.817m	106.285m - 150Ø IN 106.285m - 150Ø OUT	0.000m	1.532m	414163.085	411827.426	450Ø	PPIC	300x300 - CLASS B125	-
005	107.761m	106.100m - 150Ø IN 106.100m - 150Ø OUT	0.000m	1.661m	414157.114	411822.888	1200Ø	TYPE B	600x600 - CLASS C250	-
CWMH 100	107.427m	105.775m - 225Ø IN 105.775m - 150Ø IN 105.775m - 225Ø OUT	0.000m	1.652m	414144.737	411818.913	1200Ø	TYPE C	600x600 - CLASS D400	INVERT LEVELS ASSUMED

REV	DESCRIPTION	DATE	CHK	BY
P05	UPDATED COVER LEVELS TO SUIT REVISED FINISHED LEVELS.	28.04.25	RMR	LSG
P04	PROPOSED OUTFALL TO EXISTING HIGHWAY NETWORK.	05.09.24	RMR	SMS
P03	UPDATED TO SUIT SURFACE WATER LAYOUT	09.08.24	RMR	SMS
P02	UPDATED TO SUIT YORKSHIRE WATER COMMENTS	18.07.24	RMR	SMS
P01	ISSUED FOR INFORMATION	28.05.24	JDM	SMS

Project
DONALDSON'S VETS
HONLEY

Drawing Title
FOUL WATER DRAINAGE STRATEGY

INFORMATION

www.jpg.group
E admin@jpg.group | T +44 (0)113 263 1155



Appendix N Overland Flow Plan

DO NOT SCALE (A1)

NOTES

GENERAL NOTES

1. ALL MATERIALS AND WORKMANSHIP IS TO COMPLY WITH JPG CONSULTANTS STANDARD SPECIFICATION & ALL RELEVANT BRITISH & EUROPEAN STANDARDS.
2. THIS DRAWING IS TO BE READ IN CONJUNCTION WITH ALL RELEVANT ARCHITECTS, M & E CONSULTANTS AND JPG CONSULTANTS DRAWINGS.
3. ANY DISCREPANCIES SHOULD BE REPORTED TO THE ENGINEER IMMEDIATELY SO THAT CLARIFICATION CAN BE SOUGHT PRIOR TO COMMENCEMENT OF WORKS.

LEGEND

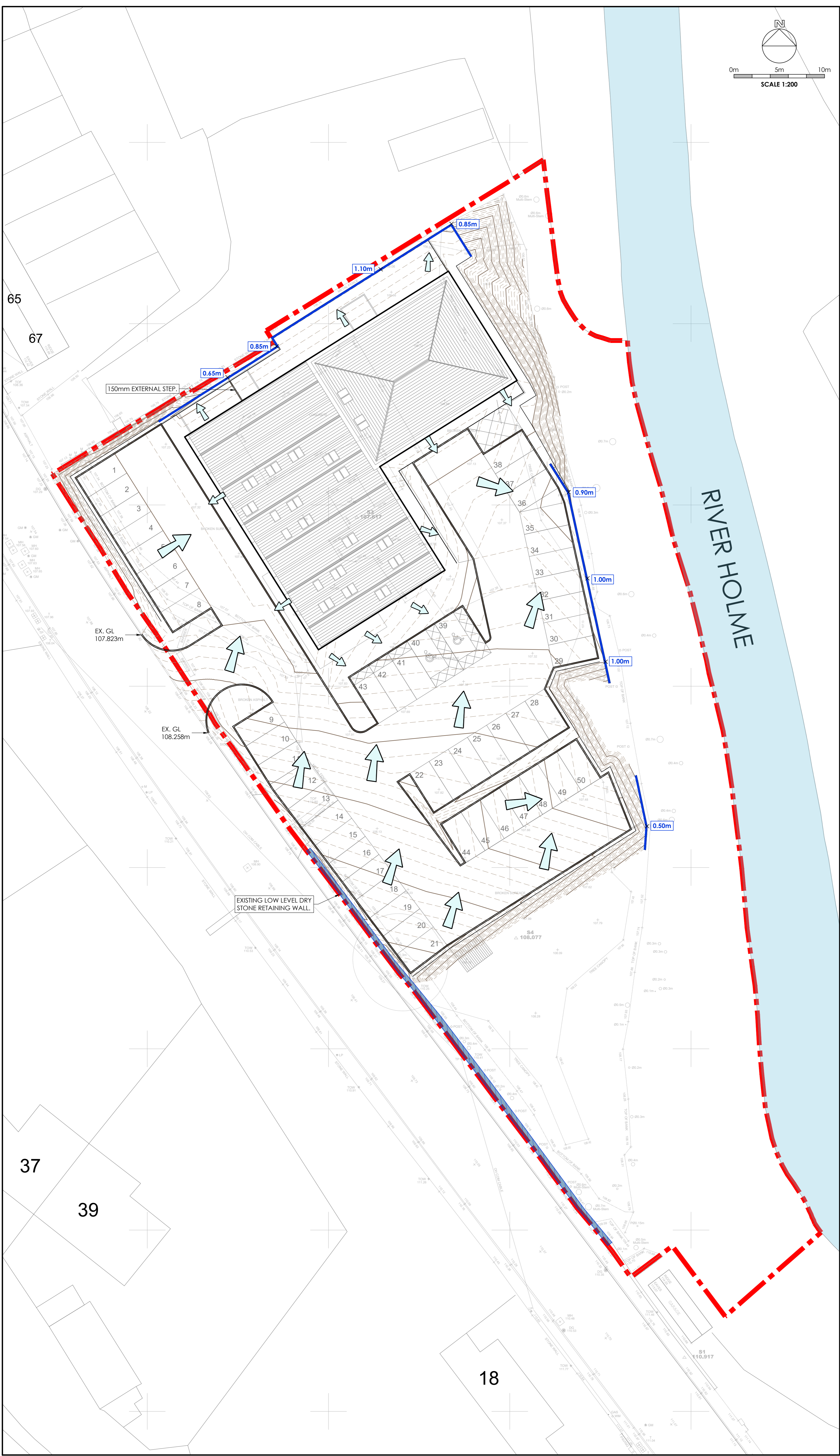
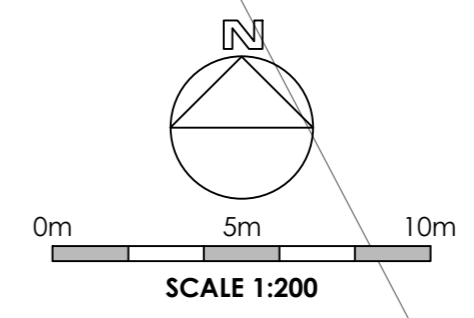

OVERLAND FLOW PLAN

SCALE 1:200

PO4	UPDATED TO SUIT LEVELS AND LATEST SITE PLAN.	28.04.25	RMR	LSG
PO3	UPDATED TO SUIT LEVELS	13.09.24	RMR	SMS
PO2	UPDATED TO SUIT LEVELS	09.08.24	RMR	SMS
PO1	FIRST ISSUE.	31.05.24	RMR	SMS
REV	DESCRIPTION	DATE	CHK	BY

Project
 DONALDSON'S VETS
 HONLEY

Drawing Title
 OVERLAND FLOW PLAN

INFORMATION



5 John Charles Way
LEEDS
LS12 6QA

Tel: 0113 263 1155
admin@jpg.group
www.jpg.group

