

GULLY REINSTATEMENT DETAIL
SCALE 1:10

HALF BATTERED KERB TYPE HB2 TO BS EN 1340 ON A MIN. 150mm THICK CONCRETE BED AND HAUNCH ST2 MIX (125mm KERB FACE).

KERBS ARE TO BE BED AND BACKED WITH ST2 CONCRETE IN ACCORDANCE WITH BS7263.PT.2.

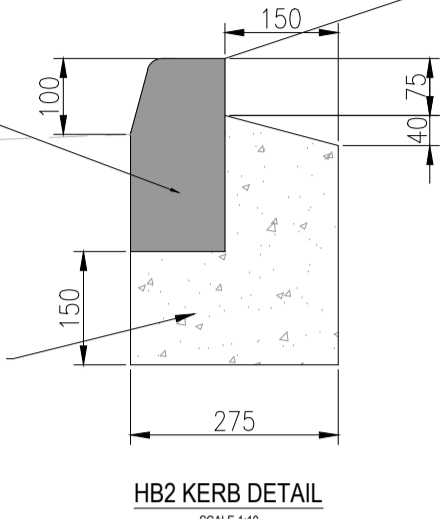

1:3

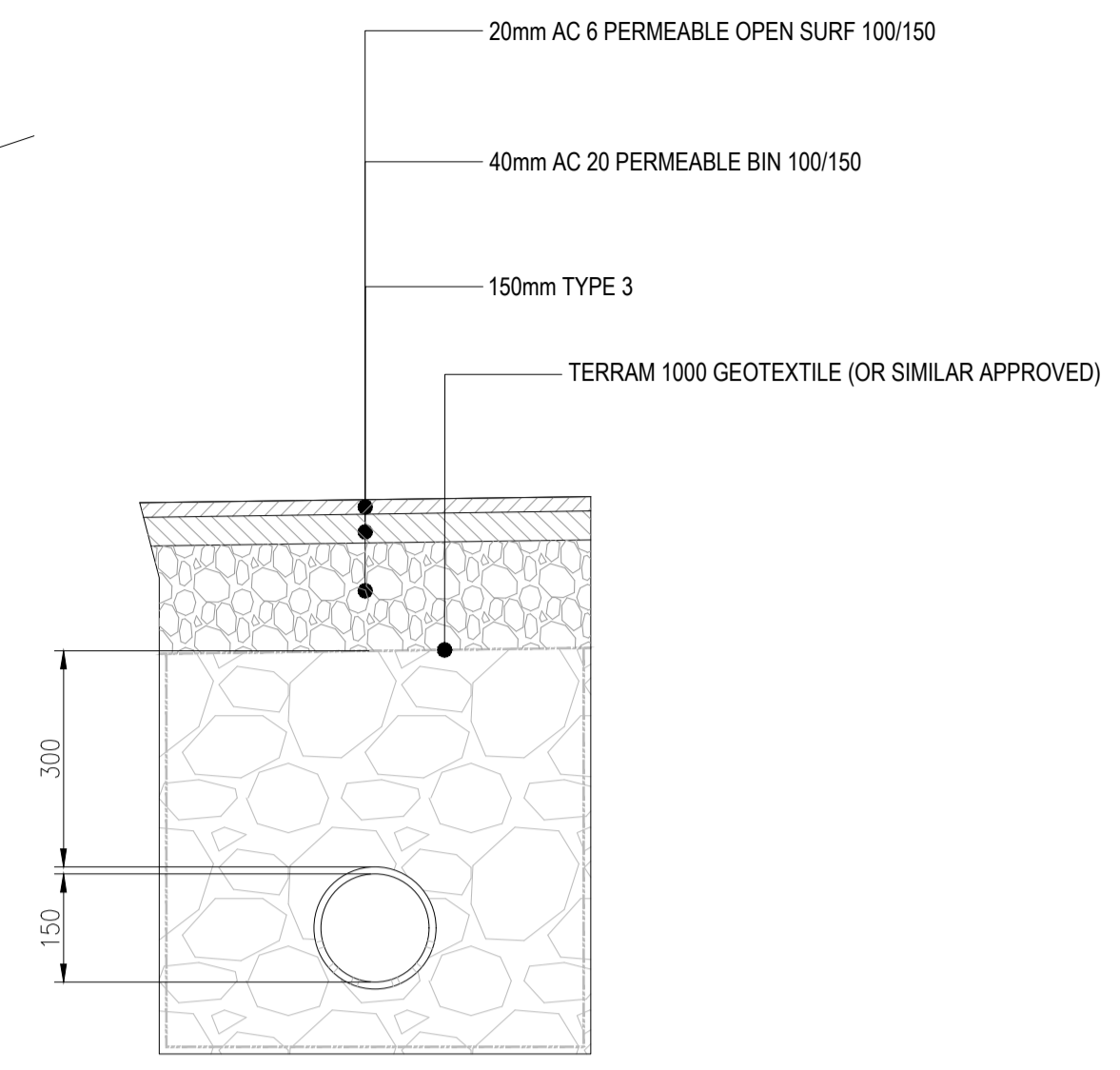

GULLY REINSTATEMENT DETAIL
SCALE 1:10

GENERAL NOTES:

- THIS DRAWING IS TO BE READ IN CONJUNCTION WITH ALL RELEVANT ARCHITECTS AND ENGINEERS DRAWINGS AND SPECIFICATIONS.
- DO NOT SCALE FROM THIS DRAWING. ANY OMISSIONS OR ERRORS ON DRAWINGS SHALL BE BROUGHT TO THE ENGINEERS ATTENTION IMMEDIATELY. ALL DIMENSIONS MUST BE CHECKED / VERIFIED ON SITE.
- ALL DIMENSIONS ARE IN MILLIMETRES UNLESS NOTED OTHERWISE.
- ALL LIGHTING COLUMNS, UTILITIES & COMMUNICATION LINES TO BE RELOCATED TO BACK OF PROPOSED FOOTWAY.
- CARRIAGEWAY AND FOOTWAY WORKS SUBJECT TO TECHNICAL APPROVAL BY KIRKLEES HIGHWAYS AND APPROPRIATE LEGAL AGREEMENTS.
- EXISTING PRIVATE DRAINAGE TO BE SURVEYED AND REMEDIATED AS REQUIRED PRIOR TO WORKS

KEY

- NEW CARRIAGEWAY CONSTRUCTION
- NEW FOOTWAY CONSTRUCTION
- EARTHWORKS BATTER 1:3
- HB2 KERB DETAIL (REFER TO CONSTRUCTION DETAILS)
- REALIGNED PROW FENCE TO MATCH EXISTING
- PROPOSED LAND DRAINAGE REFER TO ROAD CONTOUR PLANS AND ASSOCIATED LONGSECTIONS (95901 - 95905)

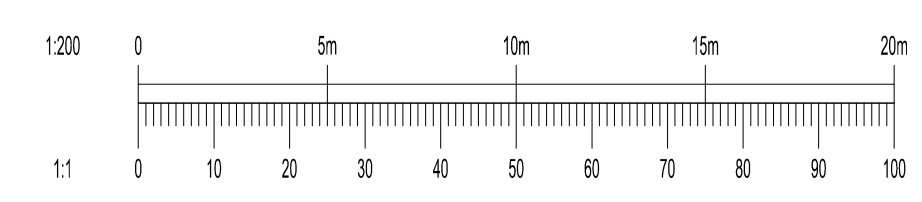
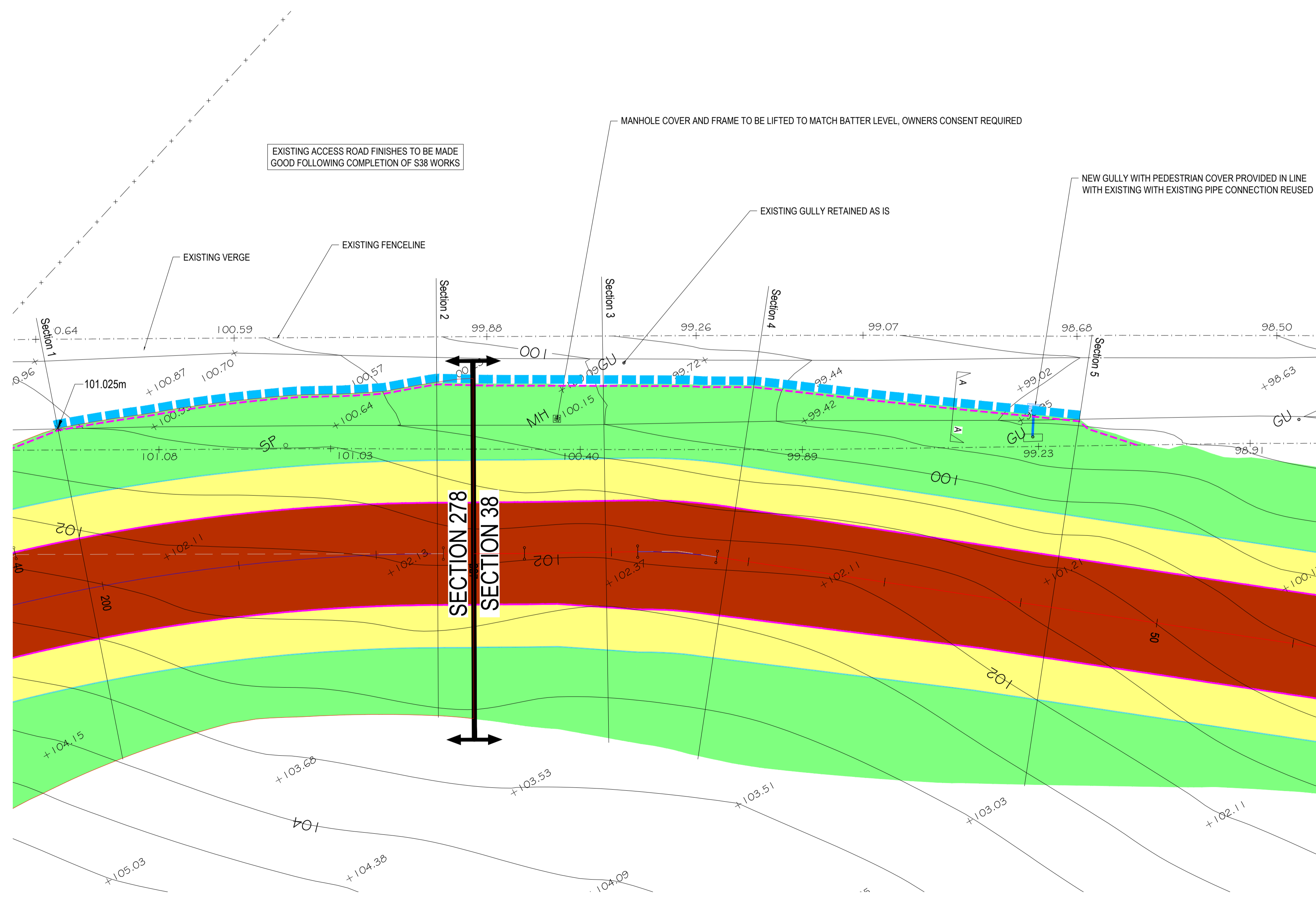

P08	FILTER TRENCH BUILD UP AMENDED TO ALLOW FOR PEDESTRIAN USE	16/11/22	JC	ACS
P07	PLAN EXTENTS WIDENED TO SHOW PROW	06/05/22	JC	ACS
P06	AMENDED FOLLOWING KLC COMMENTS	30/02/22	JC	JC
P05	REVISED TO NEW ROAD LAYOUT	24/11/21	JC	ACS
P04	REVISED TO ADDITIONAL KIRKLEES COMMENTS	28/05/21	OT	OT
P03	REVISED TO KIRKLEES COMMENTS	29/04/21	EF	OT
P02	AMENDED TO SUIT REVISED SITE ENTRANCE. PROW LINK INDICATED TO SUITE LEVEL CHANGE IMPOSED BY REVISED ALIGNMENT	23/10/20	OT	NT
P01	FIRST ISSUE	09/09/20	OT	NT
Rev:	Description:	Date:	By:	Chkd:



Rose Wharf Ground Floor, 78-80 East Street, Leeds, LS9 8EE
0113 274 8009
leeds@curtins.com
www.curtins.com

City & Structures • Transport Planning • Environmental • Infrastructure • Geotechnical • Conservation & Heritage • Principal Designer
Birmingham • Bristol • Cambridge • Cardiff • Douglas • Dublin • Edinburgh • Glasgow • Kenton • Leeds • Liverpool • London • Manchester • Nottingham

Status: ISSUED FOR INFORMATION **S2**

Project: INTERCHANGE 26, NORTH BIERLEY

Dig Title: PROW LAYOUT

Size:	A1	Date:	29/04/20	Drawn By:	OT	Designed By:	OT	Checked By:	OT
Scale:	1:250								
Project No:	065646	Originator:	CUR	Volume:	ZZ	Level:	ZZ	Type:	DR
		Role:	C	Category / Number:	90501	Rev:			

\\s07\Projects\065646 - Interchange 26 - North Bierley - WTW\GMS 4 Production\B Models & Drawings_Colour\CC0901