



## **Arboricultural Impact Assessment Report**

### **Site:**

Red Lea  
27 Church Lane  
Mirfield  
West Yorkshire  
WF14 9HX

### **Prepared for:**

Paul Bailey  
The Forge  
North Charlton  
Northumberland  
Chathill  
NE67 5HP

**Date of report:** 19<sup>th</sup> May 2021

**Reference:** OWA084 AIA Rev 2

<b><u>Table of Contents</u></b>	<b>Pg.</b>
<b>1.0 Introduction.....</b>	<b>4</b>
<b>1.1 Report Brief.....</b>	<b>4</b>
<b>1.2 Scope of the Report.....</b>	<b>4</b>
<b>1.3 Qualifications.....</b>	<b>5</b>
<b>1.4 Copyright.....</b>	<b>5</b>
<b>2.0 Data Collection.....</b>	<b>6</b>
<b>2.1 Site Visit.....</b>	<b>6</b>
<b>2.2 Site description.....</b>	<b>6</b>
<b>3.0 Development Proposals.....</b>	<b>6</b>
<b>3.1 Statutory Practice and Guidance.....</b>	<b>8</b>
<b>3.2 Tree Population.....</b>	<b>10</b>
<b>3.3 Impacts of the Proposed Development.....</b>	<b>11</b>
<b>4.0 Tree Protection Requirements.....</b>	<b>13</b>
<b>4.1 Root Protection Areas (RPAs).....</b>	<b>13</b>
<b>4.2 Protective Fencing and Exclusion Zones.....</b>	<b>14</b>
<b>4.3 Ground Protection.....</b>	<b>14</b>
<b>4.4 Ground Contamination.....</b>	<b>15</b>
<b>4.5 Underground Utility Issues.....</b>	<b>15</b>
<b>4.6 Ground Level Changes.....</b>	<b>15</b>
<b>4.7 Drainage and Storm Water Run-Off Issues.....</b>	<b>15</b>
<b>5.0 Management Recommendations.....</b>	<b>15</b>
<b>5.1 Tree Work.....</b>	<b>15</b>
<b>5.2 Arboricultural Method Statement.....</b>	<b>17</b>
<b>5.3 Pre-Start Site Meeting.....</b>	<b>17</b>
<b>5.4 Tree Retention and Sustainability of Habitat.....</b>	<b>17</b>
<b>6.0 Summary.....</b>	<b>18</b>

<b>Appendix 1 – Arboricultural Impact Assessment Plan.....</b>	<b>20</b>
<b>Appendix 2 – Tree Schedule and Recommendations.....</b>	<b>22</b>

## **1.0 Introduction**

### **1.1 Report brief**

This report has been prepared for Paul Bailey to identify and assess the implications to the trees within influencing distance of the proposed development at Red Lea, 27 Church Lane, Mirfield, WF14 9HX.

The objective of the report is to provide analysis of the proposed development in relation to the trees with:

- A Tree Removal and Protection Plan detailing the development proposals, trees to be retained and removed, tree protection fencing alignment and areas of specialised ground treatment (found in the **Arboricultural Impact Assessment Plan – Appendix 1**).
- A narrative representation of the details within this report.
- Compliance with *BS 5837:2012 Trees in Relation to Design, Demolition and Developments – Recommendations*.
- Advice on retention, removal and management of the trees.
- Protection measures throughout the construction process and afterwards.
- Details that can be incorporated into the construction considerations for the proposed development.

### **1.2 Scope of the report**

The trees within influencing distance of the site have been recorded on a Site and Tree Location plan, within the Pre-development Report (reference OWA084 PDR). This plan forms the basis of the Arboricultural Impact Assessment Plan in **Appendix 1**.

#### **1.2.1 Documents Provided**

A site plan has been supplied along with design details of the proposed plans for a dwelling with a detached garage and driveway for the initial purpose of outline planning permission. The reference for this document is: **364-Base proposed**.

### **1.2.2 Relevant background Information**

All the trees have been surveyed in accordance with British Standard 'Trees in relation to design, demolition and Construction – Recommendations BS 5837:2012, and recommendations for their management have been addressed in the Pre-development Report, reference: OWA084 PDR.

A total of 29 individual trees (**T1-T28, including T22a**) were surveyed and mapped (refer to **Appendix 2 – Tree Schedule and Recommendations**). All arboricultural information recorded during the survey is presented.

### **1.2.3 National House Building Council**

The nature of the soils on site from the British Geological Society are Sandstone bedrock with Sandstone superficial deposits. The rear garden appears to be on the edge of Pennine Lower Coal Measure Formation: Mudstone, Siltstone and Sandstone. The possibility of soil movement due to shrinkable soil content in relation to tree root activity is low.

Prior to the undertaking of foundation depth calculations, the exact location of all trees in relation to structures will be required to be verified. Any discrepancies in tree location will require further discussion with a qualified Arboricultural Consultant.

## **1.3 Qualifications**

This report has been written and produced by Flora Harding: I am qualified in arboriculture and tree care. I am a professional tree inspector with an excellent level of up to date training and skills across a wide range of Arboricultural areas. Further details of my qualifications and experience can be provided upon request.

## **1.4 Copyright**

All rights in this report are reserved. No part of it may be reproduced or transmitted, in any form or by any means, electronic, mechanical, photocopying, recording or otherwise, stored in any retrieval system of any nature, without our written permission. Its content and format are for the exclusive use of the clients. It may not be sold, lent, hired out or divulged to any third party without our written consent. © One World Arboriculture Ltd 2021.

## **2.0 Data Collection**

### **2.1 Site visit**

The site visit was undertaken on 15<sup>th</sup> June 2018 and a revisit on 19<sup>th</sup> March 2020. The weather conditions were blustery with drizzle then clearing to be sunny on the first day, and mild and calm with sunny intervals on the return visit.

### **2.2 Site description**

The site is a large detached property with large front, side and rear gardens. To the north is Church Lane, and to the west, south and east are residential dwellings of similar stature.

The front and rear gardens are interspersed with trees indicating a mature garden setting. There is a carport in the front garden adjacent to the roadside and opposite the garage of the main house.

The topography gradually slopes from 51.2 metres at the northern end of the site down to 45.2 metres in the southern corner north to south throughout the site.

## **3.0 Development Proposals**

The proposed development includes a detached dwelling with a detached garage and new driveway from Church Lane; situated to the western side of Red Lea.



**Photo 1** – The front garden to the west of the property, looking towards the south. **T8** and **T9** are in the forefront of the shrubbery, with **T6** and **T7** behind them.



**Photo 2 –** Some of the land in the rear garden where the dwelling will be situated, looking west from behind the existing property.

### **3.1 Statutory Protection and Guidance**

#### **3.1.1 National Planning Policy Framework (NPPF)**

The NPPF assumes protection of all ancient woodland and veteran trees unless it can be clearly demonstrated that the need of, or benefits of, development outweigh the loss. In this respect, ancient woodland is defined as an area which has been wooded continuously since at least 1600 AD and a veteran as a tree of exceptional value for wildlife, in the landscape, or culturally because of its great age, size or condition. On this site, there are no ancient woodland or veteran trees.

#### **3.1.2 Tree Preservation Orders & Conservation Area Designations**

In the front garden, the Oak trees (**T3, T8, T9, T10** and **T11**), all of which are Sessile Oaks of a similar age and are protected with a Tree Preservation Order referred to as ***Church Lane, Mirfield - No. 18, 1989***. The Beech (**T27**) is protected with a Tree Preservation order known as ***Church Lane, Mirfield - No. 21, 1985***; the order also includes a Sycamore (**T28**) situated on adjacent land to the east and within the front garden of no. 25 Church Lane.

Trees **T4** (Ash) and **T5** (Beech) are situated on adjacent land to the west of the site at 27a Church Lane, and are also afforded protected by an Area order within **Church Lane, Mirfield - No. 21, 1985**.

The site is not within a Conservation Area.

Where it is considered expedient to do so, local authorities reserve the right to create Tree Preservation Orders (TPO) to protect the amenity value conferred to a location by a tree or group of trees. Where a TPO is in force, lopping, topping, felling, uprooting or wilful damage caused to a tree is prohibited and such actions may be prosecuted and incur an unlimited fine. Works to TPO protected trees must only be undertaken with the written consent of the Local Planning Authority and can be granted under permissions given as part of the Planning Application.

### **3.1.3 Protected Species – Bats**

Mature trees often contain cavities, crevices and hollows which are a potential habitat for roosting bats. Bats are afforded protection under Schedule 5 of the Wildlife and Countryside Act 1981 (as amended), as well as under Schedule 2 of the Conservation of Species and Habitats Regulations 2010, and as such causing damage to a bat roost constitutes an offence.

A preliminary ground level appraisal of the wildlife habitat value of each tree was undertaken as part of the arboricultural survey. There were no features suitable to support roosting bats, other than the Ivy which grows up **T3, T7, T19, T20, T21, T22, T22a and T23**. Ivy can be used as a resting place for active bats.

Should the presence of a bat roost be suspected whilst undertaking works on any trees and on site, operations must be halted until a licensed bat handler or ecologist can provide advice.

### **3.1.4 Protected Species - Birds**

Trees are a potential habitat for nesting birds, which (as well as their nests and eggs) are protected under the Wildlife and Countryside Act 1981 (as amended). This makes it an offence to intentionally or recklessly, damage or destroy an active birds nest or any part thereof.

Due to the suitability of the trees within the survey area for nesting birds, all tree work should ideally be undertaken outside the bird nesting season (British bird nesting season: primarily March to August inclusive).

Nonetheless, some bird species will nest outside of these months and a detailed inspection of each tree should be undertaken immediately prior to the

arboricultural works being undertaken. Should an active nest be found (being built, containing eggs or chicks), then any work likely to affect the nest must be halted and resume only after the nest becomes inactive. The minimum distance away for works is 5 metres of a nest.

### **3.2 Tree population**

There were 29 trees within the survey area of the site. A schedule of all trees and groups in terms of species, condition, age management recommendations and BS 5837:2012 quality categories is provided at **Appendix 2 - Tree Schedule and Recommendations**.

The collation of trees into the retention categories are in **Table 1** below:

<b>Retention category</b>	<b>Number of trees</b>	<b>Tree/group numbers</b>
<b>A1</b>	0	-
<b>A2</b>	0	-
<b>A3</b>	0	-
<b>B1</b>	11	T1, T2, T3, T10, T11, T23, T24, T25, T26, T27 and T28
<b>B2</b>	2	T4 and T16
<b>B3</b>	0	-
<b>C1</b>	4	T5, T12, T14 and T15
<b>C2</b>	8	T6, T7, T18, T19, T20, T21, T22 and T22a
<b>C3</b>	1	T13
<b>U</b>	3	T8, T9 and T17

**Table 1 – Tree retention categories from Pre-development Report**



**Photo 3** – View north-west from the house, where the driveway to the development will be.

### **3.3 Impacts of the Proposed Development**

Table 2 lists the number and quality of trees that will require removal in order to facilitate the development proposals and those that can be retained. This is the result of an assessment based on the proposed site plan and initial discussions with the clients regarding their application strategy.

	<b>Tree Quality Category</b>			
	<b>A</b>	<b>B</b>	<b>C</b>	<b>U</b>
Trees that can be retained	0	13	10	1
Out of these the client wishes to remove the following trees if the development takes place	0	0	7	0
Trees that require removal to facilitate the Development	0	0	3	2

**Table 2: Arboricultural implications of the proposed development**

Tree	Approximate RPA impinged	Metres from driveway edge	Recommendations
T1	25%	1.65	Tree friendly, no dig cellular confinement system
T2	15-20%	3.4	As above
T3	0%		No action required
T4	0%		No action required
T5	15-20%	4.6	As above
T6	7%	4.9	As above
T7	60-65%	0	Remove the tree
T8	Removed for arboricultural reasons	0	-
T9	Removed for arboricultural reasons	0	-
T10	25%	4.5	Tree friendly, no dig cellular confinement system and ground protection
T11	30%	1.88	As above
T12	100%	(In footprint of garage)	Remove the tree
T13	35-40%	(in footprint of dwelling)	Remove the tree
T19	5%	(in footprint what looks like a patio)	Ground protection required.

**Table 4: A summary of the anticipated effects of the development on the trees.**

Arboricultural Impact Assessment Plan, please refer to **Appendix 1** for the visual representation of this information.

Please note that no further details have been provided at this stage, as this report is to accompany an outline planning application.

## **4.0 Tree Protection Requirements**

### **4.1 Root Protection Areas (RPAs)**

The areas on the Arboricultural Impact Assessment Plan showing the root protection area, is in accordance with the recommendation in the British Standard (BS 5837:2012). This represents the minimum area around each tree that must be left undisturbed to ensure their survival and is treated as sacrosanct.

In this document, OWA085 AIA Rev 1, I have adjusted the report on the basis of removing trees: **T14, T18, T19, T20, T21, T22 and T22a** (a Hawthorn, 5 Lombardy Poplars and a False Acacia). The client has requested to remove these if the development takes place, and to replant with a more suitable species choice for landscaping the site with trees into the future as a means of mitigation. These have therefore been removed from the assessment.

It is accepted practice to use the method in the British Standard 5837:2012 to identify the potential rooting area of the trees, although this figure may differ for certain species and in specific ground conditions.

On this site the majority of trees are growing in relatively homogeneous material. The only barriers to growth are likely to be areas of compacted surfacing, such as driveways and built structures. Roots are likely to be present in some of these areas, but where unfavourable conditions exist, growth will certainly be impeded. The trees are situated in the existing garden area with little or no constraints. A no dig, tree friendly cellular confinement system will be used to protect the trees in the area of the new driveway.

The morphology of roots is influenced by past and present site conditions (the presence of man-made installations), soil type, topography and drainage. This means that a tree's roots may not be uniform in their extent and the RPA may not be a circular area centred on the tree stem. But as it is difficult to predict where they are, and the root protection areas have not been offset on this occasion.

The site of the new development is presently close to trees: **T1, T2, T5, T6, T10 and T11**, but within acceptable parameters if care is taken during construction and the recommendations made within this report are followed.

Trees: **T7, T12 and T13** would be required to be removed to facilitate the development. Trees **T8 and T9** would be removed due to their arboricultural condition and the driveway has been designed to utilise this space because of the

condition of the trees. Tree **T17** has also been recommended for the removal due to its condition.

#### **4.2 Protective Fencing and Exclusion Zones**

The use of Heras barrier fencing is recommended to act as protection from the construction zone, and the area it protects is called a Construction Exclusion Zone (CEZ) around the retained trees. This must be put in place prior to the commencement of any development works, including bringing machinery or materials onto site or for the erection of site huts etc.

The CEZ acts to protect both tree roots and branches and has been extended to protect as much of the rooting area and non-development land as possible. An assessment of the requirement for crown lifting over the driveway will be assessed once outline permission has been given.

The location of the protective fencing is shown on **Appendix 1** and assumes all recommended tree works are carried out prior to its installation. It allows room for the installation of the no dig driveway, which adds another metre on each side of the functional driveway area.

The fencing must be fixed into the ground to withstand accidental impact from any machinery and to ensure that a sufficient protective area is maintained. Details of recommended protective fencing are shown on **Appendix 1**.

A weatherproof notice stating 'Tree Protection Zone– Strictly No Access' must be fixed to each fencing panel so that construction personnel can readily see it. An example notice is also shown in **Appendix 1**.

Any alteration to the fencing alignment to allow for approved activities will be made in agreement with the Council's Arboricultural Officer/Planning Officer.

The protective fencing must not be removed until the physical construction phase has been completed and all vehicles have been removed from site, to the satisfaction of the Council's Arboricultural Officer/Planning Officer.

#### **4.3 Ground Protection**

No ground protection has been recommended for this project.

#### **4.4 Ground Contamination**

It is important that the storage for liquids such as fuels, oil or paint should be located as far away from any trees as possible, due to the risk of soil contamination caused by accidental spillage.

#### **4.5 Underground Utility Issues**

Details of the route of utilities to the new dwelling will follow after outline permission has been gained.

Where the installation of services within the Construction Exclusion Zone of retained trees is unavoidable, appropriate work methods will be required to ensure the safe long-term survival of those trees. This process will require additional consultation with a qualified Arboricultural Consultant.

#### **4.6 Ground Level Changes**

Changes in soil level can have major implications to tree health.

There is no evidence that it is necessary to change the levels within the Construction Exclusion Zone and the advice of a qualified Arboricultural Consultant should be sought if level changes are required.

#### **4.7 Drainage & Storm Water Run-off Issues**

Details of drainage and storm water run-off will be provided and assessed after outline planning permission has been gained.

### **5.0 Management Recommendations**

#### **5.1 Tree Work**

The tree surgery operations presented in **Table 3** are recommended regardless of the proposed development. With the exception of **T7**, **T12** and **T13**, which are required to be removed to facilitate the development the development.

The crown lift of trees over the driveway will be assessed after outline planning permission has been gained and shall be included in the revised AIA report following permission.

**Table 3: Recommended Tree Surgery Works**

Feature Reference	Tree Work Description
T3	Carefully sever the Ivy as per the report recommendations
T6	Carefully remove the Ivy
T7	Remove the tree
T8	Remove the tree
T9	Remove the tree
T10	Carefully remove the debris and reinstate the ground level if this pile has not been in situ for more than 3 years or so. Prune to remove the dead branch.
T12	Remove the tree
T13	Remove the tree
T14	Remove the tree at the client's request
T15	Remove cuttings so the tree stem can dry out. Reinspect in around 3 years time.
G16	Remove the cuttings so the tree stems can dry out. Reinspect in around 3 years time.
T17	Remove the tree
T18	Remove the tree at the client's request
T19	Remove the tree at the client's request
T20	Remove the tree at the client's request
T21	Remove the tree at the client's request
T22	Remove the tree at the client's request
T22a	Remove the tree at the client's request

T23	Ivy and vegetation to be cleared to enable a detailed inspection.
T27	Reduce the limb which is causing the fracture by 33% so the wound can seal over - VERY HIGH PRIORITY. Monitor this annually - HIGH PRIORITY.

All tree surgery work should be carried out by a qualified contractor in accordance with BS 3998:2010 Tree work – Recommendations.

The 13 trees to be removed will be replaced to mitigate for their loss. The details of this will be contained within a Tree Planting scheme.

### **5.2 Arboricultural Method Statement**

An Arboricultural Method Statement (AMS) has been produced. This document will successfully enable the proposals to be carried out whilst safeguarding the trees on the site. It is essential that the recommendations within this report are adhered to and should guide the actions of the site operatives.

### **5.3 Pre-start Site Meeting**

To reinforce the required tree protection measures and avoid the requirement for ongoing arboricultural supervision, a pre-start meeting should be arranged between the site contractor, a qualified Arboricultural Consultant and the council's Arboricultural Officer.

During the meeting the alignment of protective fencing will be marked out, and any technical issues discussed.

### **5.4 Tree retention and sustainability of habitat**

3 trees are recommended for removal to facilitate the development (in addition to 3 initially recommended to be removed for arboricultural reasons). At the request of the client a further 7 trees will be removed; they are 'C' category trees predominantly along the rear garden boundary.

For your information; The National Planning Policy Framework (NPPF) is a material consideration in the planning process and promotes a presumption in

favour of sustainable development. In terms of the natural environment, development should minimise impacts on biodiversity and provide a net gain in biodiversity where possible.

In respect of trees, a sustainable development will be one whereby the total number, value or function provided by trees is maintained or increased or where the long-term prospects of the existing tree stock can be substantially improved. Net gains in biodiversity may be demonstrated where the number of tree species, variety of tree ages or range of niche habitats can be increased. Native, old, large or dead trees are likely to have a relatively significant impact on a scheme's environmental credentials, as will the connectivity of trees, hedges and woodland.

I believe that the design works well with most of the existing trees and enables both the key trees (in terms of high amenity) and the proposed new dwelling to coexist.

A robust tree planting scheme to mitigate lost trees will be produced.

Trees are dynamic living organisms whose structure is constantly changing. All trees can experience damage or stress from biotic and abiotic factors. Following site development, regular inspections of all retained trees should be undertaken by a qualified Arboricultural Consultant.

## **6.0 Summary**

Based on an objective assessment made in accordance with *BS 5837:2012 Trees in relation to design, demolition and construction – Recommendations*, there are 13 Category B trees, 13 Category C trees, 3 Category U trees and there are no Category A, on or adjacent to the site.

5 trees require removal to facilitate the development proposals, 1 additional tree is a category 'U' tree, and 7 category 'C' trees have been requested by the client for removal so that the site can be more appropriately landscaped.

No trees were found to have features desirable to bats with the exception of some Ivy on **T3, T7, T19, T20, T21, T22, T22a** and **T23**, which can serve as a resting place for active bats; however, this prevents the assessment of the tree for defects and has been recommended to be removed so the retained trees can be more fully inspected. The Ivy can then regrow.

Protective Heras style fencing will be required to demarcate a Construction Exclusion Zone (**CEZ**) around retained trees prior to the commencement of the development. Fencing alignment is shown on **Appendix 1** and details of the recommended Heras fencing are shown. This will restrict movements on the site which should be considered early in the construction process.

The majority of work will take place within the footprint of the building, and I have allowed 2 metres around the proposed footprint for facing up brickwork and other essential elements of the construction process. The specification of the protection will be dictated by the requirements of the builders and must be agreed with the council's Arboricultural Officer/Planning Officer prior to commencement if it differs from this.

A pre-start meeting between the site contractor, a qualified Arboricultural Consultant and the council's Arboricultural Officer will allow any technical issues to be discussed.

## **Appendices**

### **Appendix 1 – Arboricultural Impact Assessment Plan**

Key:

- Tree Stem
- Crown spread of tree to be retained
- Category U tree & canopy spread
- Crown spread of additional trees to be removed
- Root protection area
- Line of protective fencing
- No dig tree friendly driveway
- Edge area of the no dig driveway

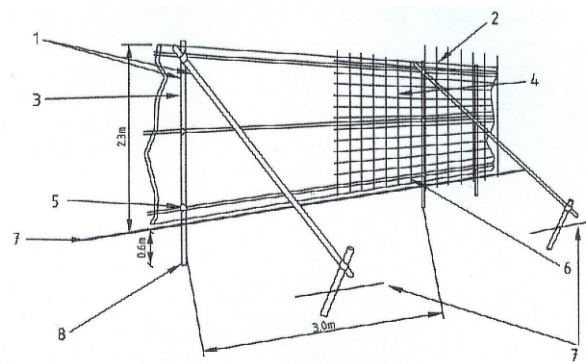
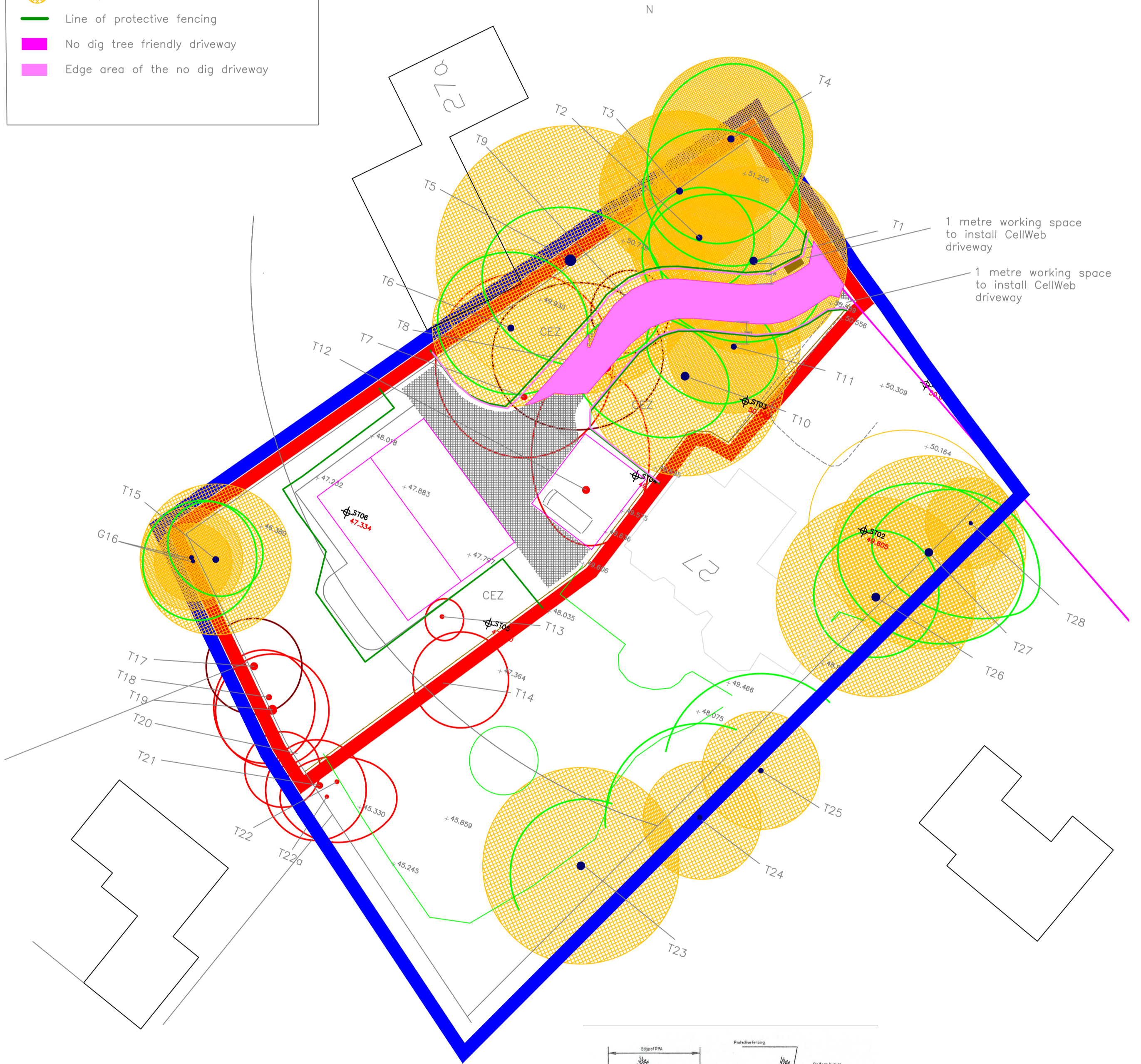

Figure 2. - Protective fencing for RPA

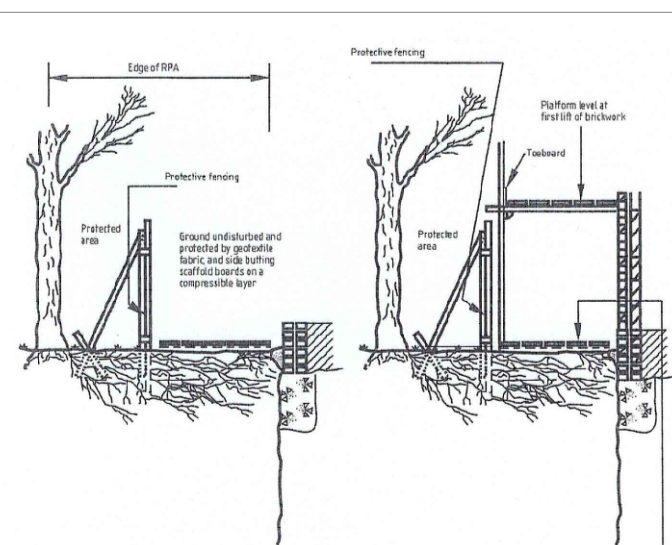

Figure 3. - Scaffolding within the RPA

## **Appendix 2 – Tree Schedule, Recommendations and Explanatory Notes**

Tree	Age, Species & Latin name	Height (m)	Crown Height (m)	Stem diameter (DBH) cm	Height (m) and direction of lowest	Crown spread in metres (N/E/S/W)	Root Protection Area radius (m)	Observations	General Physiology	General Structure	Life expectancy (years)	Amenity value	Recommendations/ Recommendations to facilitate the development	Priority for works	Re-inspection timing	Retention Category	
T1	Mature	20.9	1.6+	62	6.5 N/E/S/W	N E S W	4.4 5.8 6.7 8.5	7.44	The tree is situated in the lawn area of the front garden. It has multiple stems at 1.8 metres with a compact crown. There is twiggy growth along the main stem at 1.5 metres, yet the lowest branch is at 6.5 metres. I noted evidence that the surface roots have been damaged by the action of a mower in the past. There are no major visible defects.	Good	Good	40+	High	No action required. / No action required to facilitate the development.	n/a	5	B1
	Sessile Oak																
	<i>Quercus petraea</i>																
T2	Early mature	17.2	2.7	47	4.5 N	N E S W	3.9 4.4 4.2 4.0	5.64	The Oak tree has twin stems at 4.6 metres. There is twiggy deadwood in the inner crown due to self shading. There were no major visible defects noted.	Good	Good	40+	Mod	No action required. / No action required to facilitate the development.	n/a	5	B1
	Sessile Oak																
	<i>Quercus petraea</i>																
T3	Mature	19.2	5.0	53 over Ivy	5.7 W	N E S W	5.2 9.5# 3.7 3.0	6.36	The tree is situated close to the boundary wall (20cm), and the crown predominantly grows over on to adjacent land. The tree is clad in Ivy and is suppressed within the garden by T2. It has twin stems at an estimated height of 4.7 metres (the union was obscured by Ivy). There are watershoots throughout the main stem which is natural for the tree species. Due to the proximity of the wall to the tree I predict that it will be in the region of 10-20 years before the tree comes into contact with the wall. Aside from this the tree may live in excess of 40 years. Believed to be T6 in TPO No.18 1989.	Good	Good	10-20	Mod	Carefully sever the Ivy as per the report recommendations. / No action is required to facilitate the development	Mod	5	B1
	Sessile Oak																
	<i>Quercus petraea</i>																
T4	Mature	20.2	7+	54#	8 E	N E S W	6.0# 6.0# 8.5 6.0	6.48	The Ash is situated on adjacent land along the roadside behind a gate. It has been crown lifted to give clearance of the telephone cables. There has been excessive pruning to give clearance up the main stem to 7.9 metres. The tree has a relatively sparse crown and potentially the early stages of Ash Dieback. To date mature trees have proved to be more resilient when affected with Ash Dieback than younger trees. No access was possible to thoroughly inspect the tree.	Fair	Fair	20-40	Mod	Monitor for signs of Ash Dieback. Enable access to fully assess the tree. / No action is required to facilitate the development.	High	1	B2
	Ash																
	<i>Fraxinus excelsior</i>																
T5	Mature	20#	6.3	89#	5.5 W	N E S W	4.2 8.0# 8.0 6.1	10.68	The Beech tree is situated on adjacent land and has twin stems at 5.5 metres. It is situated very close to the boundary fence and this also prevented a detailed inspection of the tree. It was noted that it has a slightly sparse crown than I would expect to see.	Fair	Good	20-40	Mod	Gain access to inspect fully. / No action is required to facilitate the development.	Mod	3	C1
	Common Beech																
	<i>Fagus sylvatica</i>																
T6	Early mature	19#	2.5#	55 over Ivy	2.2 W	N E S W	6.0# 6.0# 5.2 6.0#	6.24	The Sycamore is Ivy clad and the crown is situated close to the boundary close to the roof of the neighbouring property, but clear of it. The crown has somewhat reduced in size, and there were no major visible defects.	Good	Good	40+	Mod	Carefully remove the Ivy./ No action is required to facilitate the development.	High	5	C2
	Sycamore																
	<i>Acer pseudoplatanus</i>																
T7	Early mature	20#	3.6+	49 over Ivy	3# W	N E S W	9.9# 6.6# 4.8 6.6#	5.64	The Sycamore has Ivy growth. The crown appears more sparse than I would expect to see for this species. There were no major visible defects.	Fair	Good	10-20	Mod	Clear the Ivy to enable an inspection next time. / Remove the tree to facilitate the development.	Low	5	C2 / U
	Sycamore																
	<i>Acer pseudoplatanus</i>																

# indicates estimated

Tree	Age, Species & Latin name	Height (m)	Crown Height (m)	Stem diameter (DBH) cm	Height (m) and direction of lowest	Crown spread in metres (N/E/S/W)	Root Protection Area radius (m)	Observations	General Physiology	General Structure	Life expectancy (years)	Amenity value	Recommendations/ Recommendations to facilitate the development	Priority for works	Re-inspection timing	Retention Category
T8	Mature	21#	2+	64	4.7 N	N E S W	7.68	The tree has multiple stems at an estimated 4.3 metres has a column of decay on the northern side from ground level up to 1.5 metres, and there is a wound from ground level up to 1 metre. There is a long decayed cavity (the skewer goes in as far as 12cm and upwards in excess of 30cm beyond this). There is a brown/cubicle rot with woodworm present. At this point the tree is hollowing out despite the good occluded growth around the wound. There is a small gridled root on the south-eastern side. Oak rarely drop limbs as the wood is incredibly strong even when dead, but if the garden is frequently used which I understand it is, then I would advice caution during severe weather instances. Believed to be T2 in TPO No.18 1989. March 2020 - reinspection, the tree sounded hollow up to 1.5 metres on the left side of the wound. The right side sounded okay.	Good	Poor	40+	Mod	Original survey said: Monitor annually for progress of the cavity to ensure it does not exceed two thirds of the total area otherwise the structural integrity may be compromised. At this time I recommend that the tree is removed for safety reasons. Consider retrenchment pruning to reduce overly long limbs such as those on the western side. March 2020 I recommend the removal of the tree. / Tree to be removed.	Mod	n/a	U
	Sessile Oak															
	<i>Quercus petraea</i>															
T9	Early mature	17#	3+	46	5	N E S W	5.52	The Oak has two different wounds located between ground level to 3.2 metres, they are starting to occlude but have decay (woodworm). The wounds will hollow out over time to create cavities such as those in T8. There are three pieces of long deadwood within the crown: one at 5.7 metres (this is a big branch with a fork) and two at 10 metres. There is a rope swing on the lowest branch on the southern side. Believed to be T5 in TPO No.18 1989. March 2020 - reinspection, the tree sounded hollow up to 2 metres and the wound is soft at the base.	Fair	Fair	40+	Mod	Original survey said: Remove the deadwood throughout the crown. March 2020 I recommend the removal of the tree. / Tree to be removed.	Mod	5	U
	Sessile Oak															
	<i>Quercus petraea</i>															
T10	Mature	20.3#	8+	66	8.8 W	N E S W	7.92	There is a log pile and garden debris on the west side up to around 1 metre. The tree has previously been crown lifted in the past, and I noted a large, long dead branch at 8.5 metres on the western side, towards the front porch. Believed to be T3 in TPO No.18 1989.	Good	Good	40+	High	Carefully remove the debris and reinstate the ground level if this pile has not been in situ for more than 3 years or so. Prune to remove the dead branch. / No action is required to facilitate the development.	High	5	B1
	Sessile Oak															
	<i>Quercus petraea</i>															
T11	Early mature	22.8	2+	45	7.0 S	N E S W	5.28	There is a wound from a torn out branch on the western side. I consider that the tree has possibly been topped at 7 metres (estimated) and the lateral branches have become the main leaders. Believed to be T4 in TPO No.18 1989.	Good	Fair	40+	Mod	No action required. / No action required to facilitate the development.	n/a	5	B1
	Sessile Oak															
	<i>Quercus petraea</i>															

Tree	Age, Species & Latin name	Height (m)	Crown Height (m)	Stem diameter (DBH) cm	Height (m) and direction of lowest	Crown spread in metres (N/E/S/W)	Root Protection Area radius (m)	Observations	General Physiology	General Structure	Life expectancy (years)	Amenity value	Recommendations/ Recommendations to facilitate the development	Priority for works	Re-inspection timing	Retention Category
T12	Mature	10.7#	4.4	72	6.5 N	9.4 4.7 4.4# 4.0#	8.64	The large main limbs which were codominant leaders have been significantly reduced in the past (essentially topping the tree). This has led to re-growth, giving a heavy crown which is touching the guttering of the property. It is likely that these new branches have weaker attachments and I recommend that they are not allowed to grow to become too heavy and extended in length. Beech are not good at resisting decay and are also known to drop limbs when the structural integrity is insufficient to carry the load. Topping a mature tree is considered poor practice as it produces large wounds at the top of the tree with no defence for decay fungi and water to enter. As a result, this point of the tree may have columns of decay. March 2020 inspection - the structure of the Beech tree could be seen as there were no leaves on the tree. The photos taken of the tree show 2 limbs which have been topped resulting in long, thin regrowth. This means that there are 2 smaller sections of tree which will be slowly rotting, rather than 1 main stem. The long term future of this tree has been compromised.	Good	Fair at present	20-40	Mod	Selectively prune to reduce the end weight on the branches by the property to give clearance of at least 2 metres. Whilst there perform an aerial inspection of the area where the tree was topped and if it is sound wood (not decayed) then prune the extended limbs to reduce the loading by 20% all over (inclusive of the branches by the property). If the wood is decaying re-pollard the tree to remove the growth around the area of the decayed wood. Take the pollard back further along the main stems until sound wood is found. I am happy to return to site to advise on this further./ Remove the tree to facilitate the development.	High	5	C1 / U
	Common Beech															
	<i>Fagus sylvatica</i>															
T13	Mature	4.7	1.6	35	1.8 N/E/S/W	1.4 1.7 1.9 1.3	4.2	The tree is situated in the rear garden and has been grafted at the base. It has multiple stems at 1.8 metres, which have been pruned to provide a maximum crown height of 4.7 metres. There is a wound on the eastern side where a branch was torn out. Due to these factors the tree has no lateral spread indicative of the species and for this reason I have reduced the amenity value and category for retention.	Good	Good	10-20	Low	No action required. / Remove the tree to facilitate the development.	n/a	5	C3 / U
	Cherry															
	<i>Prunus sp.</i>															
T14	Mature	7.1	2.1	40	2.6 E	3.7 3.4 3.9 4.2	4.8	This tree has a metal seat around. There is a large cavity at 1.25 metres, which measures about 35 centimetres by 17 centimetres high. It extends upwards and probably joins the wounding on the branch above to create a column of decay. The tree has torn out branches and a third of sound wood remaining. The tree is obviously well regarded as it has been chosen to house the seating within the garden. In my experience Hawthorn can survive in quite a decrepit state however given the use by the family I have to make remedial recommendations if the tree is to be retained.	Good	Poor	<10	Mod	Reduce end weight to 3.2 metres and monitor the progress of the tree. The other options are to remove the tree and plant a replacement elsewhere in the garden, or see if how it recovers if it is coppiced. / The client wishes to remove the tree and plant a more suitable species, if the development takes place.	High	2	C1 / U
	Hawthorn															
	<i>Crataegus monogyna</i>															
T15	Mature	14	1+	50	2.14 W	4.1 3.3 5.2 5.6	6	There are grass cuttings piled up to a height of 1.04 metres. Any materials covering the main stem is not ideal as it promotes dampness and rot in the region; grass cuttings increase the acidity of the soil and also hold moisture against the main stem. There is a bleeding canker to the main stem, indicating a chemical response to either a bacterial or fungal infection.	Fair	Poor	10-20	Mod	Remove cuttings so the tree stem can dry out. Reinspect in around 3 years time. / No action is required to facilitate the development.	Mod	3	C1
	Horse Chestnut															
	<i>Aesculus hippocastanum</i>															

# indicates estimated

Tree	Age, Species & Latin name	Height (m)	Crown Height (m)	Stem diameter (DBH) cm	Height (m) and direction of lowest	Crown spread in metres (N/E/S/W)	Root Protection Area radius (m)	Observations	General Physiology	General Structure	Life expectancy (years)	Amenity value	Recommendations/ Recommendations to facilitate the development	Priority for works	Re-inspection timing	Retention Category	
G16	Early mature/Mature Hawthorn and Lombardy Poplar	12#	4+#	LP 34 + Haw 29 #	2.4 N	5.0# N 5.0# E 0.0 S 2.0 W	4.08, 3.48	There are grass cuttings piled up mainly against the Lombardy Poplar. The grass cuttings increase acidity of the soil and retain moisture which can cause localised rotting of the main stem. Both trees are growing close together in the rear corner of the garden.	Good	Good	40+	Mod	Remove the cuttings so the tree stems can dry out. Reinspect in around 3 years time. / No action is required to facilitate the development.	Mod	3	B2	
	Crataegus monogyna/ Populus Niara																
T17	Mature Lombardy Poplar	24.5	5	60#	5 SE	3.8# all round	7.2	There is fire damage at the base of the tree. There appears to be loss of a branch in the centre of the crown, and I have concerns of safety due to growth strips which could indicate internal cracking or decay. The tree has characteristically tight branch unions.	Good	Poor	<10	Mod	Remove the tree./ Tree to be removed.	High	n/a	U	
	Populus Nigra																
T18	Mature Lombardy Poplar	23.5	6+	46#	6# S	N E S W	4.0 4.0 5.0# 4.0	5.52	There are tight unions throughout the tree, which is typical for the species. The presence of dense vegetation has prevented a detailed inspection.	Good	Fair	10-20	High	Clear the vegetation and reinspect./ The client wishes to remove the tree and plant a more suitable species, if the development takes place.	High	1	C2 / U
	Populus Nigra																
T19	Mature Lombardy Poplar	24.5	6+	75#	6# S	N E S W	4.5# All Round	9	There is considerable ivy cladding and vegetation on this tree, preventing a detailed inspection. Tight unions are also within this tree.	Fair	Fair	<10	High	Ivy and vegetation to be cleared to enable a detailed inspection. / The client wishes to remove the tree and plant a more suitable species, if the development takes place.	High	1	C2 / U
	Populus Nigra																
T20	Mature Lombardy Poplar	22.5	6+	42#	6# S	N E S W	3 All Round	5.04	There is considerable ivy cladding and vegetation on this tree thus preventing a detailed inspection. The soil levels are also high around the base; this can cause localised rotting. Tight unions are also within this tree.	Good	Fair	10-20	High	Ivy and vegetation to be cleared to enable a detailed inspection. The soil will also need to be carefully removed. / The client wishes to remove the tree and plant a more suitable species, if the development takes place.	High	1	C2 / U
	Populus Nigra																
T21	Mature Lombardy Poplar	17#	5 +	49 over ivy	5 All Around	N E S W	4 # All Round	5.88	There is ivy affecting this tree thus preventing a detailed inspection. There are tight unions within the tree.	Good	Fair	10-20	High	Ivy to be cleared to enable a detailed inspection. / The client wishes to remove the tree and plant a more suitable species, if the development takes place.	High	1	C2 / U
	Populus Nigra																
T22	Mature False Acacia	9.5	1.6	34.8 combined	3.7 SW	N E S W	1.8 4.6 5.0 3.7	4.17	This tree multiple stems at 1 metre. It is leaning for light into the lawn area of the garden and this is adaptive growth which is stable rather than a lean caused by instability. When inspected the tree was clad with ivy and previous pruning has left stubs and torn branches.	Fair	Fair	10-20	Low	Ivy to be carefully cleared and remedial prune to remove the branch stubs and torn out branches. / The client wishes to remove the tree and plant a more suitable species, if the development takes place.	Mod	3	C2 / U
	Robinia pseudoacacia																

# indicates estimated

Tree	Age, Species & Latin name	Height (m)	Crown Height (m)	Stem diameter (DBH) cm	Height (m) and direction of lowest	Crown spread in metres (N/E/S/W)	Root Protection Area radius (m)	Observations	General Physiology	General Structure	Life expectancy (years)	Amenity value	Recommendations/ Recommendations to facilitate the development	Priority for works	Re-inspection timing	Retention Category	
T22a	Early Mature	12#	5 +	31 over Ivy	5+ All Round	N E S W	4 All Round	3.72	This tree is clad with ivy and dense vegetation both prevented a detailed inspection.	Fair	Fair	10-20	High	Ivy and vegetation to be cleared to enable a detailed inspection. / The client wishes to remove the tree and plant a more suitable species, if the development takes place.	High	1	C2 /U
	Lombardy Poplar																
	<i>Populus Nigra</i>																
T23	Mature Sessile Oak	17.6	4	65# over Ivy	4.2 East onto Site	N E S W	E 6.0	7.8	There is dense vegetation and ivy cladding on this tree which is preventing a detailed inspection and also trash piled up. I could not get close to the tree.	Indeterminate	Indeterminate	40+	High	Ivy and vegetation to be cleared to enable a detailed inspection. / No action is required to facilitate the development.	High	1	B1
	<i>Quercus petraea</i>																
T24	Early mature Oak	16.5	6#	39#	6.5# East onto Site	N E S W	E 7.7	4.68	This tree is situated on adjacent land with no access permitted to take the measurements of the crown and to inspect all of the tree. I did note that the tree has a high crown.	Good	Good	40+	High	Enable access to perform a full inspection. / No action is required to facilitate the development.	High	1	B1
	<i>Quercus sp.</i>																
T25	Early mature Oak	16	5.3#	39#	5.1# N	N E S W	E 7.5#	4.68	This tree is situated on adjacent land with no access permitted to take the measurements of the crown and to inspect all of the tree. I did note that the tree has a high crown.	Good	Good	40+	High	Enable access to perform a full inspection. / No action is required to facilitate the development.	High	1	B1
	<i>Quercus sp.</i>																
T26	Mature Sessile Oak	21.8	4.5	66	5.8 W	N E S W	5.3 4.9 4.8 5.0	7.92	This is situated in the tarmac driveway by the fence in the front garden between the house and the car port. It has a large torn out branch on the eastern side at 5.8 metres leaving a short, thick stub.	Good	Good	40+	High	No action is required. / No action is required to facilitate the development.	n/a	5	B1
	<i>Quercus petraea</i>																
T27	Mature Common Beech	16.9	2.6	64	6.4 W	N E S W	5.4 7.9 7.0 7#	7.68	This beech tree has many small leaves. There is a cupboard door fracture and a big split going down the tree. There is also a dead branch on top of it. I categorise the tree as 'B' at present. This tree is T28 in TPO No.21 1985.	Fair	Poor	10-20	High	Reduce the limb which is causing the fracture by 33% so the wound can seal over - VERY HIGH PRIORITY. Monitor this annually - HIGH PRIORITY. / No action is required to facilitate the development.	Very High/High	1	B1
	<i>Fagus sylvatica</i>																
T28	Early mature Sycamore	18.6	3.4	30#	None over the site	N E S W	0.0 6.9 8.0 6.7	3.6	This tree is situated on adjacent land close to the boundary (About 1 metre from the retaining wall) and is suppressed by T27. There is flush cut pruning with occluded growth and cavity formation. The tree blocks the cast of the street light. This tree is T26 in TPO No.21 1985.	Good	Fair	20-40	Mod	Inform the owners that the tree requires pruning to be clear of the streetlight. / No action is required to facilitate the development.	High	5	B1
	<i>Acer pseudoplatanus</i>																

## Explanatory Notes

### Taken from the BS 5837:2012 – Trees in relation to design, demolition and construction – Recommendations

<b>Trees unsuitable for retention</b>			
<b>Category U</b>			
Those in such a condition that they cannot realistically be retained as living trees in the context of the current land use for longer than 10 years			
<ul style="list-style-type: none"> <li>• Trees that have a serious, irremediable, structural defect, such that their early loss is expected due to collapse, including those that will become unviable after removal of other category U trees (e.g. where, for whatever reason, the loss of companion shelter cannot be mitigated by pruning)</li> <li>• Trees that are dead or showing signs of significant, immediate, and irreversible overall decline.</li> <li>• Trees infected with pathogens of significance to the health and/or safety of other trees nearby, or very low quality trees suppressing adjacent trees of better quality</li> </ul>			
Note: Category U trees can have existing or potential conservation value which it might be desirable to preserve.			
<b>Trees to be considered for retention</b>			
	<b>Mainly Arboricultural qualities 1</b>	<b>Mainly landscape qualities 2</b>	<b>Mainly cultural values, including conservation 3</b>
<b>Category A</b> <b>Trees of high quality</b> with an estimated remaining life expectancy of at least 40 years	Trees that are particularly good examples of their species, especially if rare or unusual; or those that are essential components of groups or formal or semi-formal arboricultural features (e.g. the dominant and/or principal trees within an avenue)	Trees, groups or woodlands of particular visual importance	Trees, groups or woodlands of significant conservation, historical, commemorative or other value (e.g. veteran trees or wood-pasture)

<p><b>Category B</b>  <b>Trees of moderate quality</b> with an estimated remaining life expectancy of at least 20 years</p>	<p>Trees that might be included in Category A, but were downgraded because of impaired condition (e.g. the presence of significant defects, including unsympathetic past management and storm damage), such that they are unlikely to be suitable for retention for beyond 40 years, or trees lacking the special quality necessary to merit the category A designation</p>	<p>Trees present in numbers, usually growing as groups or woodlands, such that they attract a higher collective rating than they might as individuals; or trees occurring as collectives but situated so as to make little visual contribution to the wider locality</p>	<p>Trees with material conservation or other cultural value</p>
<p><b>Category C</b>  <b>Trees of low quality</b> with an estimated remaining life expectancy of at least 10 years, or young trees with a stem diameter below 150mm</p>	<p>Unremarkable trees of very limited merit or such impaired condition that they do not qualify in higher categories</p>	<p>Trees present in groups or woodlands, but without this conferring on them significantly greater collective landscape value; and/or trees offering low or only temporary/transient landscape benefits</p>	<p>Trees with no material conservation or other cultural value</p>

Produced by:

Date 19<sup>th</sup> May 2021



One World Arboriculture Ltd  
2-4 Southgate, Elland, West Yorkshire, HX5 0BW.

W: [www.oneworldarboriculture.co.uk](http://www.oneworldarboriculture.co.uk)

**Services we offer:**

**Reports**

- ✓ **Development** – Tree Constraints Plans, Arboricultural Impact Assessments, Method Statements and Site Supervision
- ✓ **Tree Condition** – Risk Assessments, Tree Hazard analysis, Tree Health Care
- ✓ **Tree Planting Schemes**
- ✓ **Mortgage**
- ✓ **Insurance**
- ✓ **Subsidence**

**Talks and Tours**

- ✓ **Tree Safety - Your duty as a Tree Owner / Manager**
- ✓ **Tree Identification**
- ✓ **Environmental Education**