



## **Arboricultural Method Statement Report**

### **Site:**

Red Lea  
27 Church Lane  
Mirfield  
West Yorkshire  
WF14 9HX

### **Prepared for:**

Mr P Bailey  
The Forge  
North Charlton  
Chathill  
Northumberland  
NE67 5HP

Date of report: 29<sup>th</sup> April 2021  
Reference: OWA084 AMS rev.2

<b><u>Table of Contents</u></b>	<b>Pg.</b>
<b>1.0 Introduction.....</b>	<b>3</b>
<b>1.1 Report Brief.....</b>	<b>3</b>
<b>1.2 Relevant Background Information.....</b>	<b>4</b>
<b>1.3 Purpose of the Report.....</b>	<b>4</b>
<b>1.4 Copyright.....</b>	<b>4</b>
<b>2.0 Sequence of Works.....</b>	<b>5</b>
<b>2.1 Tree Works Prior to Demolition and Construction.....</b>	<b>6</b>
<b>2.1.1 Recommendations for Tree Works.....</b>	<b>6</b>
<b>2.1.2 Protected Species.....</b>	<b>6</b>
<b>2.2 Tree Works.....</b>	<b>6</b>
<b>2.3 Protective Fencing .....</b>	<b>8</b>
<b>2.4 Ground Protection.....</b>	<b>11</b>
<b>2.5 Construction of the new driveway.....</b>	<b>11</b>
<b>2.6 Construction of the new dwelling and garage.....</b>	<b>12</b>
<b>2.7 Removal of Protective Fencing.....</b>	<b>12</b>
<b>2.8 Other Tree Protection Measures.....</b>	<b>12</b>
<b>3.0 Other Tree Works .....</b>	<b>13</b>
<b>4.0 Liaison with the Tree Officer.....</b>	<b>14</b>
<b>5.0 Post Construction Tree Care.....</b>	<b>14</b>
<b>Appendix 1 – Tree Protection Plan.....</b>	<b>15</b>
<b>Appendix 2 – Tree Schedule and Recommendations.....</b>	<b>17</b>
<b>Appendix 3 – Protected Species.....</b>	<b>23</b>
<b>Appendix 4 – Technical Specification.....</b>	<b>24</b>
<b>Appendix 5 – Generic Installation Method.....</b>	<b>30</b>

## 1.0 Introduction

### 1.1 Report Brief

This report has been prepared for Mr Bailey to detail the methods to be used to protect the trees during the course of the site works: to erect a new dwelling and garage in the rear of Red Lea 27 Church Lane, Mirfield, West Yorkshire, WF14 9HX, and a separate driveway to the western side of the site.

The report is the final in the series; the aim is to provide details of the proposed stages of works and measures necessary to protect the retained trees in order to gain outline planning permission.

The objectives of the report are to use information drawn from my previous pre-development arboricultural report and arboricultural impact assessment, reference: OWA084 PDR and OWA084 AIA Rev 2.

To provide a tree protection plan detailing the location and type of protective fencing, locations of fencing alignment and areas requiring specialised ground protection. This report also details the specification of the no dig, tree friendly driveway (found in the **Tree Protection Plan – Appendix 1 and Appendices 4 and 5**).

- Produce a narrative report of the protection measures prior to and throughout the construction phases, with essential stages for the above protection identified in a methodical order.
- Ensure compliance with two British Standards: *BS 5837:2012 Trees in Relation to Design, Demolition and Developments – Recommendations*, and *BS3998:2010 Tree Works - Recommendations*.
- Provide a statement for the siting of materials and the site compound.
- Provide information on the driveway specification, essential to protect the trees.
- Identify all reasonable precautionary action as well contingencies to safeguard the trees.

- Enable this document to satisfy the Local Planning Authority that trees are adequately safeguarded within influencing distance of the proposed works on the site.

## **1.2 Relevant Background Information**

The first stage of my work was to inspect all trees and record the findings within the Pre-development Report, which is the first document.

The arboricultural impact assessment involved making a professional assessment using my knowledge and experience to evaluate the details of the proposed development in relation to the trees. Then to the resolve issues which were reasonably practicable with the client.

Most of the trees on the site are protected by either of two tree preservation orders: In the front garden, the Oak trees (**T3, T8, T9, T10 and T11**), all of which are Sessile Oaks of a similar age and are protected with a Tree Preservation Order referred to as ***Church Lane, Mirfield - No. 18, 1989.***

The Beech (**T27**) is protected with a Tree Preservation order known as ***Church Lane, Mirfield - No. 21, 1985;*** the order also includes a Sycamore (**T28**) situated on adjacent land to the east and within the front garden of no. 25 Church Lane.

Trees **T4** (Ash) and **T5** (Beech) are situated on adjacent land to the west of the site at 27a Church Lane and are also afforded protected by an Area order within ***Church Lane, Mirfield - No. 21, 1985.***

The site is not within a Conservation Area.

## **1.3 Purpose of the Report**

This report is of great importance; it is a document that gives clear guidance for tree protection and must be adhered to, before, during and after the construction phase by all parties concerned, i.e. form part of the specification and schedule of works issued to the building contractor, and form part of the contract.

It should also be made part of site training for all workers.

Complete compliance with this document, will ensure the trees are adequately protected and maintained whilst site works take place.

## 1.4 Copyright

All rights in this report are reserved. No part of it may be reproduced or transmitted, in any form or by any means, electronic, mechanical, photocopying, recording or otherwise, stored in any retrieval system of any nature, without our written permission. Its content and format are for the exclusive use of the client. It may not be sold, lent, hired out or divulged to any third party without our written consent. © One World Arboriculture Ltd 2021.

## 2.0 Sequence of Works

Sequence	Action	✓	Initial
Stage 1	Obtain approval from the Local Authority planning office for this report.		
Stage 2	Undertake the tree works (as detailed at <b>Appendix 2</b> ) at least one month prior to starting the site works.		
Stage 3	Have the Local Planning Authority (LPA) inspect the proposed lines of the fencing prior to their installation (as shown on the <b>Tree Protection Plan</b> in <b>Appendix 1</b> ). Once inspected and approved, the protective fencing can be erected and must not to be moved or breached.  Take photos of the trees lining the access routes and adjacent to areas where site work will take place to keep visual records of their condition.		
Stage 4	Undertake the construction of the new driveway.		
Stage 5	Undertake the construction works of the new dwelling at the rear of the property using traditional strip foundations.  Construct patio areas and walkways.		
Stage 6	Undertake the installation of services by moling along the route of the new driveway and to the property.		
Stage 7	Once works are completed. Contact LPA to invite them to a site inspection/ give approval to remove the fencing structures.		
Stage 8	Once approval is given, remove the protective fencing and fill any holes with soil.		

<b>Stage 9</b>	Inspect the trees for signs of any damage and undertake post construction care.		
<b>Stage 10</b>	Undertake the tree planting/landscaping plan.		
<b>Stage 11</b>	Maintain newly planting trees until established.		

**Table 1 – Outline of the sequence of works**

## **2.1 Tree Works prior to Demolition and Construction**

### **2.1.1 Recommendations for Tree Works**

All work must be carried out to BS 3998: 2010 – Tree Work - *Recommendations* and should be carried out by qualified and experienced approved contractor who is adequately insured, and their skills and training are up to date.

Please bring to my attention any tree defects seen by a tree surgeon or the client that were not apparent to me at the time of the survey. As these may have a bearing on the situation and action taken.

### **2.1.2 Protected Species**

It is important to remember the law regarding protected species: refer to **Protected Species - Appendix 3** within this report. As a result, it is recommended that the works are undertaken at least one month in advance of other preparatory works on the site. This is a precautionary measure designed to help prevent delays in the proceeding works if protected species were found to be present.

## **2.2 Tree Works**

The sequential action for carrying out tree works throughout the course of the site works are detailed in this section.

A total of 29 individual trees (**T1-T29**) were surveyed and mapped (refer to **Appendix 2 – Tree Schedule and Recommendations**). All arboricultural information recorded during the survey is presented.

The site of the new development is presently close to trees: **T1, T2, T3, T5, T6, T10, T11, T14** and **T15**, but within acceptable parameters if care is taken during construction and the recommendations made within this report are followed.

In summary the works are:

© Copyright 2021

### Tree Removal – Without damaging adjacent trees

1. The removal of trees: **T7, T12 and T13** would be required to be removed to facilitate the development. Trees **T8, T9 and T17** would be removed due to their arboricultural condition.
2. The removal of **T14, T18, T19, T20, T21, T22 and T22a** (a Hawthorn, 5 Lombardy Poplars and a False Acacia) to be replaced with a tree planting scheme. This is at the owner's request if the development scheme is given approval so a better selection of species can be selected.

### Tree Pruning

1. **T27** Reduce the limb which is causing the fracture by 33% so the wound can seal over - **VERY HIGH PRIORITY**. Monitor this annually - **HIGH PRIORITY**.
2. **T10** Prune to remove the dead branch.
3. No pruning thought to be required to facilitate the development.

Carry out the works in accordance with BS 3998:2010.

The remainder of the works listed below are for arboricultural reasons and affect the growing environment of the trees.

**T3:** Carefully sever the Ivy as per the report recommendations.

**T6:** Carefully remove the Ivy.

**T10:** Carefully remove the debris and reinstate the ground level if this pile has not been in situ for more than 3 years or so.

**T15:** Remove cuttings so the tree stem can dry out. Reinspect in around 3 years time.

**G16** Remove the cuttings so the tree stems can dry out. Reinspect in around 3 years time.

**T23** Ivy and vegetation to be cleared to enable a detailed inspection.

Once the tree works have been undertaken, all the trees can then be safeguarded using protective fencing and ground protection measures where specified.

### **2.3 Protective Fencing**

The careful installation of the protective measures is the next logical step after completion of the tree works.

To reinforce the required tree protection measures and avoid the requirement for ongoing arboricultural supervision, a pre-start meeting should be arranged with the site contractors, the Council's Tree Officer and/or me. During the meeting the alignment of protective fencing will be marked out, and any technical issues discussed.

The fencing will be erected in accordance with **Appendix 1 – Tree Protection Plan** and the specification below from BS 5837: 2012. The figure below shows a vertical and horizontal framework which is well braced to resist impact. The standard scaffold poles/clamps should be spaced at 3 metre intervals and securely driven into the ground, taking care to avoid any underground services and structural roots. I recommend that Heras fencing is used.

It is essential that no site works shall start until the Tree Officer is satisfied that the protective fencing is sited and erected correctly.

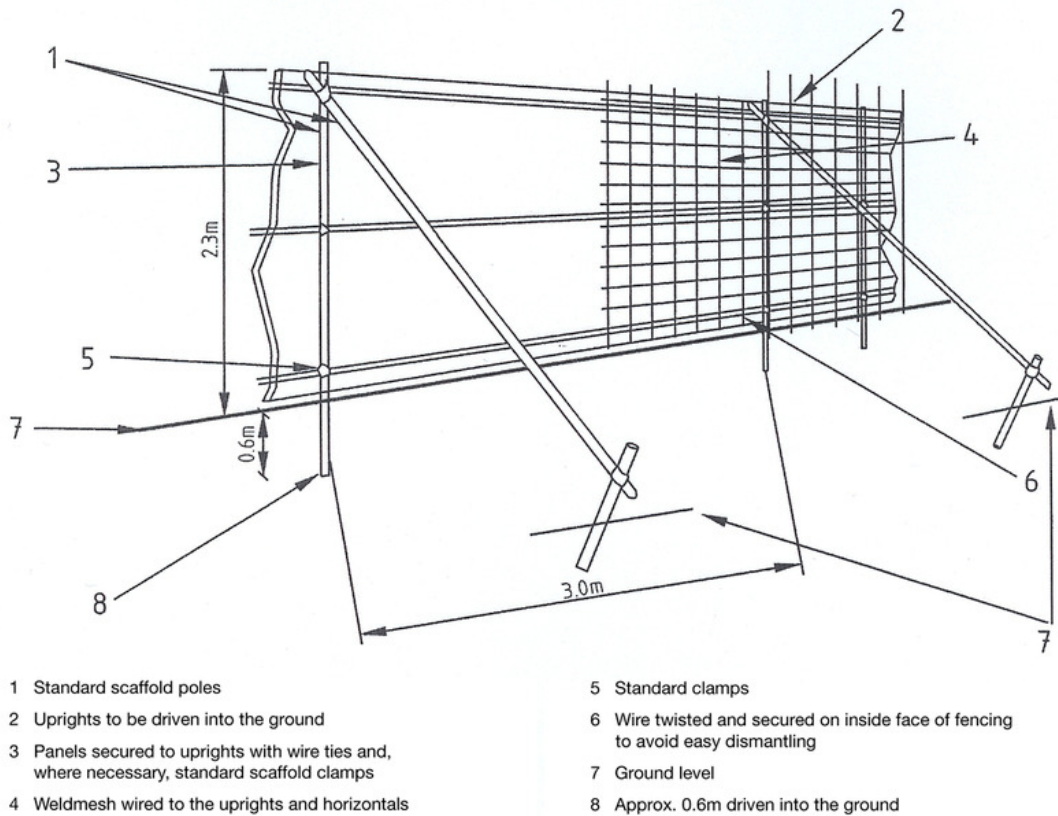

**Figure 1 – As specified in British Standard 5837:2012**

This type of installation method is recommended for use in soft standing areas, such as it is appropriate for all the trees within the site.

The purpose is to prevent any damage occurring to parts of the trees, both above and below ground. The temporary protective fencing creates what is known as a Construction Exclusion Zone (CEZ). It must be made known to all persons on site that this area is to be considered a restricted area; no pedestrians, vehicles, storage of materials, equipment or machinery are allowed within the CEZ. I recommend inspecting and taking photos of the trees and the fencing at regular intervals to record the condition of them.

Along the line of the fencing, it is essential that waterproof signs are attached in clear view; one on each fence panel, using the wording below:

## **Tree Protection Zone**

**Strictly no access**

Do not move this fencing without prior authorisation from One World Arboriculture

Please refer to the Arboricultural Method Statement relating to the approved planning permission

Thank you

It is essential that all people on site are aware of the access restrictions that apply to the areas where the trees are enclosed.

The protective fencing must be regularly inspected for faults or damage by the site manager or another responsible named person, and a written record kept. Any faults or defects must be repaired or replaced as soon as possible.

If any trees are damaged, contact should be made with me as soon as possible to discuss the safety and arboricultural implications, and to arrange for any remedial works to be undertaken.

The fencing should be sited in accordance with the measurements of the Plan – **Appendix 1**, so as to be outside of the root protection areas (RPAs) where shown.

I did not offset the root protection areas on the plan, as it is impossible to know exactly where the roots will be, so in order to adequately safeguard the trees I have specified protective fencing. It is proposed to fence off and protect as much of the area as possible in order to protect the trees and their roots.

## **2.4 Ground Protection**

No ground protection has been specified.

## **2.5 Construction of the New driveway**

It will be constructed from a cellular confinement system, as specified as it is a 'tree friendly' configuration that allows roots to function beneath them.

The CellWeb product by GeoSynthetics Ltd, has been specified as appropriate given its reputation within the arboricultural industry: a site specific **Technical Specification** is given in **Appendix 4**, although this requires updating to reflect the latest area specified as driveway and the **Generic Installation Method** is provided in **Appendix 5**. *Please note that for maintenance purposes, it has been decided to surface the driveway with porous tarmac rather than clean angular stone.*

It is important that the installation of the new driveway shall be carried out by a competent company, experienced in successfully working in close proximity to

trees, using the CellWeb product. It is essential that further liaison with Geosynthetics is undertaken for assistance with the remainder of the driveway project.

All materials will be stored on the existing driveway of Red Lea, i.e. on existing hard surfacing.

## **2.6 Construction of the new dwelling and garage**

The foundations for the new building will be tradition strip foundations as all works are outside of the root protection areas of retained trees. The garage will be constructed on a concrete raft.

All works to the build will take place within the footprint with an allowance of 2 metres working space; this will enable access to face up the blockwork and install the glasswork etc.,

Any scaffolding required to construct the roof will be carried out from the areas within the protective fencing.

## **2.7 Removal of the Protective Fencing**

After the construction period, a post development meeting will be arranged to inspect the site and grant approval for the protective fencing to be carefully dismantled and removed from site.

## **2.8 Other Tree Protection Measures**

### **2.8.1 Ground Level Changes**

No ground level changes are required within the vicinity of any RPA of the trees on site apart from the installation of the no dig driveway.

### **2.8.2 Exposed Roots**

It is important that in the event of any tree roots being exposed within the RPA of a tree, they must be left as intact as possible. The use of hand tools will be employed to carefully digging around the roots.

Exposed roots can become irreparably damaged quite quickly due to climate conditions associated with exposure, and wounding. In the event of exposure

cover with a dry cloth such as hessian to prevent freezing overnight, or a wet one on warm days.

If roots are to be severed then clean, straight cuts must be made, in order to minimise the extent of wounding. If roots with a diameter of greater than 25mm are encountered, I would be required to be informed and potentially attend the site to make a full assessment and recommendations.

### **2.8.3 Aerial Tree Parts**

The site workers must be careful to avoid any contact with the canopies of the trees on the site in order to avoid damage.

### **2.8.4 Underground Utility Issues**

The route of utilities will be installed using moling technique beneath the new driveway to avoid the roots of the trees. All utilities will be installed outside of the Construction Exclusion Zone shown on **Appendix 1**.

### **2.8.5 Location of Site Compound**

The location of the site compound (toilets and storage of materials) is not known but there will be room to site them on the existing driveway.

No heavy machinery is permitted on the site until the new driveway has been constructed.

### **2.8.6 Ground Contamination**

It is important that the storage for liquids such as fuels, oil or paint should be located as far away from any trees as possible, due to the risk of soil contamination caused by accidental spillage.

## **3.0 Other Tree Works**

### **3.1 Accidental Tree Damage**

If, during the course of any site work any trees are damaged, I will be contacted immediately in order to agree appropriate remedial action.

As a precautionary measure it is recommended that photographs of the trees are taken (along the access routes and adjacent to work areas) before, during and after the construction phase in order that any perceived damage can be

recorded and verified.

### **3.2 Post Construction**

When the construction phase has been completed, and authorisation has been given to carefully remove the fencing, it is recommended that any holes created from the removal of the short anchoring scaffold poles are infilled with soil from the garden.

It is not foreseen that tree works will be necessary after the construction has taken place, and it is recommended an inspection of the trees is made after the fencing has been removed to ensure no damage has occurred, such as compaction to the soil or broken branches within the canopy.

### **4.0 Liaison with the Tree Officer**

It is recommended to consult the Council's Tree Officer for:

- 1 Agreement in the event that any alteration to the fencing alignment is necessary to allow for approved activities.
- 2 Approval of, and as a precautionary measure for post-construction remedial tree works are to be carried out on the trees.
- 3 Gaining approval for the removal of the protective fencing after the construction phase has been completed.

### **5.0 Post Construction Tree Care**

Once the works are completed it is advised that new tree planting will take place on the land to mitigate the loss of trees: **T7, T8, T9, T12, T13, T17, T18, T19, T20, T21, T22** and **T22a**. I can advise on this outside of this report and within the Tree Planting Scheme which will be produced.

Trees are dynamic living organisms whose structure is constantly changing. All trees can experience damage or stress from biotic and abiotic factors. Following site development, regular inspections of all retained trees should be undertaken by a qualified Arboricultural Consultant such as myself.

## **Appendices**

### **Appendix 1 – Arboricultural Method Statement Plan**

**Tree Protection Zone**

Strictly No Access

Do not remove this fencing without prior authorization from One World Arboriculture Ltd

Tel: 0781 551 6648 or email: [flora@oneworldarboriculture.co.uk](mailto:flora@oneworldarboriculture.co.uk)

Please refer to the Arboricultural Impact Assessment Report relating to the approved planning permission.

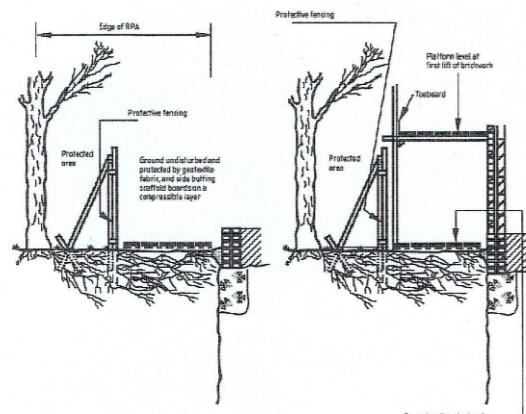

Figure 3. - Scaffolding within the RPA

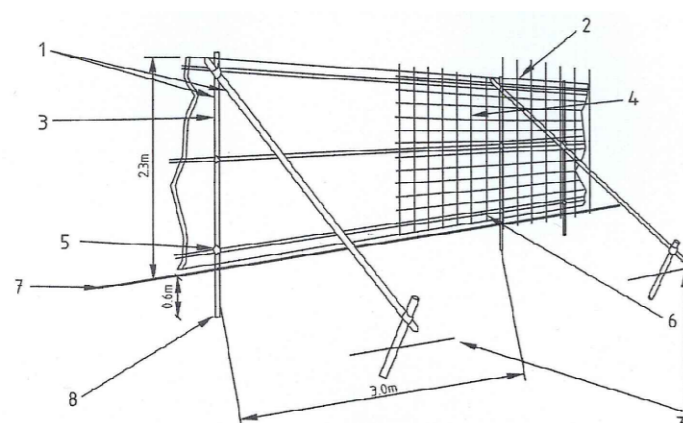

Figure 2. - Protective fencing for RPA

Key

●	Tree stems
○	Trees to be retained
○	Tree to be removed
○	Root Protection Area
○	Root Incursion Zone
—	Line of protective fencing



## Appendix 2 – Tree Schedule and Recommendations

Tree	Age, Species & Latin name	Height (m)	Crown Height (m)	Stem diameter (DBH) cm	Height (m) and direction of lowest	Crown spread in metres (N/E/S/W)	Root Protection Area radius (m)	Observations	General Physiology	General Structure	Life expectancy (years)	Amenity value	Recommendations/ Recommendations to facilitate the development	Priority for works	Re-inspection timing	Retention Category	
T1	Mature	20.9	1.6+	62	6.5 N/E/S/W	N E S W	4.4 5.8 6.7 8.5	7.44	The tree is situated in the lawn area of the front garden. It has multiple stems at 1.8 metres with a compact crown. There is twiggy growth along the main stem at 1.5 metres, yet the lowest branch is at 6.5 metres. I noted evidence that the surface roots have been damaged by the action of a mower in the past. There are no major visible defects.	Good	Good	40+	High	No action required. / No action required to facilitate the development.	n/a	5	B1
	Sessile Oak																
	<i>Quercus petraea</i>																
T2	Early mature	17.2	2.7	47	4.5 N	N E S W	3.9 4.4 4.2 4.0	5.64	The Oak tree has twin stems at 4.6 metres. There is twiggy deadwood in the inner crown due to self shading. There were no major visible defects noted.	Good	Good	40+	Mod	No action required. / No action required to facilitate the development.	n/a	5	B1
	Sessile Oak																
	<i>Quercus petraea</i>																
T3	Mature	19.2	5.0	53 over lvy	5.7 W	N E S W	5.2 9.5# 3.7 3.0	6.36	The tree is situated close to the boundary wall (20cm), and the crown predominantly grows over on to adjacent land. The tree is clad in lvy and is suppressed within the garden by T2. It has twin stems at an estimated height of 4.7 metres (the union was obscured by lvy). There are watershoots throughout the main stem which is natural for the tree species. Due to the proximity of the wall to the tree i predict that it will be in the region of 10-20 years before the tree comes into contact with the wall. Aside from this the tree may live in excess of 40 years. Believed to be T6 in TPO No.18 1989.	Good	Good	10-20	Mod	Carefully sever the Ivy as per the report recommendations. / No action is required to facilitate the development	Mod	5	B1
	Sessile Oak																
	<i>Quercus petraea</i>																
T4	Mature	20.2	7+	54#	8 E	N E S W	6.0# 6.0# 8.5 6.0	6.48	The Ash is situated on adjacent land along the roadside behind a gate. It has been crown lifted to give clearance of the telephone cables. There has been excessive pruning to give clearance up the main stem to 7.9 metres. The tree has a relatively sparse crown and potentially the early stages of Ash Dieback. To date mature trees have proved to be more resilient when affected with Ash Dieback than younger trees. No access was possible to thoroughly inspect the tree.	Fair	Fair	20-40	Mod	Monitor for signs of Ash Dieback. Enable access to fully assess the tree. / No action is required to facilitate the development.	High	1	B2
	Ash																
	<i>Fraxinus excelsior</i>																
T5	Mature	20#	6.3	89#	5.5 W	N E S W	4.2 8.0# 8.0 6.1	10.68	The Beech tree is situated on adjacent land and has twin stems at 5.5 metres. It is situated very close to the boundary fence and this also prevented a detailed inspection of the tree. It was noted that it has a slightly sparse crown than I would expect to see.	Fair	Good	20-40	Mod	Gain access to inspect fully. / No action is required to facilitate the development.	Mod	3	C1
	Common Beech																
	<i>Fagus sylvatica</i>																
T6	Early mature	19#	2.5#	55 over lvy	2.2 W	N E S W	6.0# 6.0# 5.2 6.0#	6.24	The Sycamore is lvy clad and the crown is situated close to the boundary close to the roof of the neighbouring property, but clear of it. The crown has somewhat reduced in size, and there were no major visible defects.	Good	Good	40+	Mod	Carefully remove the lvy./ No action is required to facilitate the development.	High	5	C2
	Sycamore																
	<i>Acer pseudoplatanus</i>																
T7	Early mature	20#	3.6+	49 over lvy	3# W	N E S W	9.9# 6.6# 4.8 6.6#	5.64	The Sycamore has lvy growth. The crown appears more sparse than I would expect to see for this species. There were no major visible defects.	Fair	Good	10-20	Mod	Clear the lvy to enable an inspection next time. / Remove the tree to facilitate the development.	Low	5	C2 / U
	Sycamore																
	<i>Acer pseudoplatanus</i>																

Tree	Age, Species & Latin name	Height (m)	Crown Height (m)	Stem diameter (DBH) cm	Height (m) and direction of lowest	Crown spread in metres (N/E/S/W)	Root Protection Area radius (m)	Observations	General Physiology	General Structure	Life expectancy (years)	Amenity value	Recommendations/ Recommendations to facilitate the development	Priority for works	Re-inspection timing	Retention Category
T8	Mature	21#	2+	64	4.7 N	N E S W	7.68	The tree has multiple stems at an estimated 4.3 metres has a column of decay on the northern side from ground level up to 1.5 metres, and there is a wound from ground level up to 1 metre. There is a long decayed cavity (the skewer goes in as far as 12cm and upwards in excess of 30cm beyond this). There is a brown/cubicle rot with woodworm present. At this point the tree is hollowing out despite the good occluded growth around the wound. There is a small gridled root on the south-eastern side. Oak rarely drop limbs as the wood is incredibly strong even when dead, but if the garden is frequently used which I understand it is, then I would advice caution during severe weather instances. Believed to be T2 in TPO No.18 1989. March 2020 - reinspection, the tree sounded hollow up to 1.5 metres on the left side of the wound. The right side sounded okay.	Good	Poor	40+	Mod	Original survey said: Monitor annually for progress of the cavity to ensure it does not exceed two thirds of the total area otherwise the structural integrity may be compromised. At this time I recommend that the tree is removed for safety reasons. Consider retrenchment pruning to reduce overly long limbs such as those on the western side. March 2020 I recommend the removal of the tree. / Tree to be removed.	Mod	n/a	U
	Sessile Oak															
	<i>Quercus petraea</i>															
T9	Early mature	17#	3+	46	5	N E S W	5.52	The Oak has two different wounds located between ground level to 3.2 metres, they are starting to occlude but have decay (woodworm). The wounds will hollow out over time to create cavities such as those in T8. There are three pieces of long deadwood within the crown: one at 5.7 metres (this is a big branch with a fork) and two at 10 metres. There is a rope swing on the lowest branch on the southern side. Believed to be T5 in TPO No.18 1989. March 2020 - reinspection, the tree sounded hollow up to 2 metres and the wound is soft at the base.	Fair	Fair	40+	Mod	Original survey said: Remove the deadwood throughout the crown. March 2020 I recommend the removal of the tree. / Tree to be removed.	Mod	5	U
	Sessile Oak															
	<i>Quercus petraea</i>															
T10	Mature	20.3#	8+	66	8.8 W	N E S W	7.92	There is a log pile and garden debris on the west side up to around 1 metre. The tree has previously been crown lifted in the past, and I noted a large, long dead branch at 8.5 metres on the western side, towards the front porch. Believed to be T3 in TPO No.18 1989.	Good	Good	40+	High	Carefully remove the debris and reinstate the ground level if this pile has not been in situ for more than 3 years or so. Prune to remove the dead branch. / No action is required to facilitate the development.	High	5	B1
	Sessile Oak															
	<i>Quercus petraea</i>															
T11	Early mature	22.8	2+	45	7.0 S	N E S W	5.28	There is a wound from a torn out branch on the western side. I consider that the tree has possibly been topped at 7 metres (estimated) and the lateral branches have become the main leaders. Believed to be T4 in TPO No.18 1989.	Good	Fair	40+	Mod	No action required. / No action required to facilitate the development.	n/a	5	B1
	Sessile Oak															
	<i>Quercus petraea</i>															

Tree	Age, Species & Latin name	Height (m)	Crown Height (m)	Stem diameter (DBH) cm	Height (m) and direction of lowest	Crown spread in metres (N/E/S/W)	Root Protection Area radius (m)	Observations	General Physiology	General Structure	Life expectancy (years)	Amenity value	Recommendations/ Recommendations to facilitate the development	Priority for works	Re-inspection timing	Retention Category
T12	Mature	10.7#	4.4	72	6.5 N	9.4 E 4.7 S 4.4# W 4.0#	8.64	The large main limbs which were codominant leaders have been significantly reduced in the past (essentially topping the tree). This has led to re-growth, giving a heavy crown which is touching the guttering of the property. It is likely that these new branches have weaker attachments and I recommend that they are not allowed to grow to become too heavy and extended in length. Beech are not good at resisting decay and are also known to drop limbs when the structural integrity is insufficient to carry the load. Topping a mature tree is considered poor practice as it produces large wounds at the top of the tree with no defence for decay fungi and water to enter. As a result, this point of the tree may have columns of decay. March 2020 inspection - the structure of the Beech tree could be seen as there were no leaves on the tree. The photos taken of the tree show 2 limbs which have been topped resulting in long, thin regrowth. This means that there are 2 smaller sections of tree which will be slowly rotting, rather than 1 main stem. The long term future of this tree has been compromised.	Good	Fair at present	20-40	Mod	Selectively prune to reduce the end weight on the branches by the property to give clearance of at least 2 metres. Whilst there perform an aerial inspection of the area where the tree was topped and if it is sound wood (not decayed) then prune the extended limbs to reduce the loading by 20% all over (inclusive of the branches by the property). If the wood is decaying re-pollard the tree to remove the growth around the area of the decayed wood. Take the pollard back further along the main stems until sound wood is found. I am happy to return to site to advise on this further./ Remove the tree to facilitate the development.	High	5	C1 / U
	Common Beech															
	<i>Fagus sylvatica</i>															
T13	Mature	4.7	1.6	35	1.8 N/E/S/W	1.4 E 1.7 S 1.9 W 1.3	4.2	The tree is situated in the rear garden and has been grafted at the base. It has multiple stems at 1.8 metres, which have been pruned to provide a maximum crown height of 4.7 metres. There is a wound on the eastern side where a branch was torn out. Due to these factors the tree has no lateral spread indicative of the species and for this reason I have reduced the amenity value and category for retention.	Good	Good	10-20	Low	No action required. / Remove the tree to facilitate the development.	n/a	5	C3 / U
	Cherry															
	<i>Prunus sp.</i>															
T14	Mature	7.1	2.1	40	2.6 E	3.7 E 3.4 S 3.9 W 4.2	4.8	This tree has a metal seat around. There is a large cavity at 1.25 metres, which measures about 35 centimetres by 17 centimetres high. It extends upwards and probably joins the wounding on the branch above to create a column of decay. The tree has torn out branches and a third of sound wood remaining. The tree is obviously well regarded as it has been chosen to house the seating within the garden. In my experience Hawthorn can survive in quite a decrepit state however given the use by the family I have to make remedial recommendations if the tree is to be retained.	Good	Poor	<10	Mod	Reduce end weight to 3.2 metres and monitor the progress of the tree. The other options are to remove the tree and plant a replacement elsewhere in the garden, or see if how it recovers if it is coppiced. / The client wishes to remove the tree and plant a more suitable species, if the development takes place.	High	2	C1 / U
	Hawthorn															
	<i>Crataegus monogyna</i>															
T15	Mature	14	1+	50	2.14 W	4.1 E 3.3 S 5.2 W 5.6	6	There are grass cuttings piled up to a height of 1.04 metres. Any materials covering the main stem is not ideal as it promotes dampness and rot in the region; grass cuttings increase the acidity of the soil and also hold moisture against the main stem. There is a bleeding canker to the main stem, indicating a chemical response to either a bacterial or fungal infection.	Fair	Poor	10-20	Mod	Remove cuttings so the tree stem can dry out. Reinspect in around 3 years time. / No action is required to facilitate the development.	Mod	3	C1
	Horse Chestnut															
	<i>Aesculus hippocastanum</i>															

# indicates estimated

Tree	Age, Species & Latin name	Height (m)	Crown Height (m)	Stem diameter (DBH) cm	Height (m) and direction of lowest	Crown spread in metres (N/E/S/W)	Root Protection Area radius (m)	Observations	General Physiology	General Structure	Life expectancy (years)	Amenity value	Recommendations/ Recommendations to facilitate the development	Priority for works	Re-inspection timing	Retention Category
G16	Early mature/Mature Hawthorn and Lombardy Poplar	12#	4+#	LP 34 + Haw 29 #	2.4 N	5.0# N 5.0# E 0.0 S 2.0 W	4.08, 3.48	There are grass cuttings piled up mainly against the Lombardy Poplar. The grass cuttings increase acidity of the soil and retain moisture which can cause localised rotting of the main stem. Both trees are growing close together in the rear corner of the garden.	Good	Good	40+	Mod	Remove the cuttings so the tree stems can dry out. Reinspect in around 3 years time. / No action is required to facilitate the development.	Mod	3	B2
	Crataegus monogyna/ Populus Niara															
T17	Mature Lombardy Poplar	24.5	5	60#	5 SE	3.8# all round	7.2	There is fire damage at the base of the tree. There appears to be loss of a branch in the centre of the crown, and I have concerns of safety due to growth strips which could indicate internal cracking or decay. The tree has characteristically tight branch unions.	Good	Poor	<10	Mod	Remove the tree./ Tree to be removed.	High	n/a	U
	Populus Nigra															
T18	Mature Lombardy Poplar	23.5	6+	46#	6# S	4.0 N 4.0 E 5.0# S 4.0 W	5.52	There are tight unions throughout the tree, which is typical for the species. The presence of dense vegetation has prevented a detailed inspection.	Good	Fair	10-20	High	Clear the vegetation and reinspect./ The client wishes to remove the tree and plant a more suitable species, if the development takes place.	High	1	C2 / U
	Populus Nigra															
T19	Mature Lombardy Poplar	24.5	6+	75#	6# S	4.5# All Round	9	There is considerable ivy cladding and vegetation on this tree, preventing a detailed inspection. Tight unions are also within this tree.	Fair	Fair	<10	High	Ivy and vegetation to be cleared to enable a detailed inspection. / The client wishes to remove the tree and plant a more suitable species, if the development takes place.	High	1	C2 / U
	Populus Nigra															
T20	Mature Lombardy Poplar	22.5	6+	42#	6# S	3 All Round	5.04	There is considerable ivy cladding and vegetation on this tree thus preventing a detailed inspection. The soil levels are also high around the base; this can cause localised rotting. Tight unions are also within this tree.	Good	Fair	10-20	High	Ivy and vegetation to be cleared to enable a detailed inspection. The soil will also need to be carefully removed. / The client wishes to remove the tree and plant a more suitable species, if the development takes place.	High	1	C2 / U
	Populus Nigra															
T21	Mature Lombardy Poplar	17#	5 +	49 over ivy	5 All Around	4 # All Round	5.88	There is ivy affecting this tree thus preventing a detailed inspection. There are tight unions within the tree.	Good	Fair	10-20	High	Ivy to be cleared to enable a detailed inspection. / The client wishes to remove the tree and plant a more suitable species, if the development takes place.	High	1	C2 / U
	Populus Nigra															
T22	Mature False Acacia	9.5	1.6	34.8 combined	3.7 SW	1.8 N 4.6 E 5.0 S 3.7 W	4.17	This tree multiple stems at 1 metre. It is leaning for light into the lawn area of the garden and this is adaptive growth which is stable rather than a lean caused by instability. When inspected the tree was clad with ivy and previous pruning has left stubs and torn branches.	Fair	Fair	10-20	Low	Ivy to be carefully cleared and remedial prune to remove the branch stubs and torn out branches. / The client wishes to remove the tree and plant a more suitable species, if the development takes place.	Mod	3	C2 / U
	Robinia pseudoacacia															

# indicates estimated

Tree	Age, Species & Latin name	Height (m)	Crown Height (m)	Stem diameter (DBH) cm	Height (m) and direction of lowest	Crown spread in metres (N/E/S/W)	Root Protection Area radius (m)	Observations	General Physiology	General Structure	Life expectancy (years)	Amenity value	Recommendations/ Recommendations to facilitate the development	Priority for works	Re-inspection timing	Retention Category	
T22a	Early Mature	12#	5 +	31 over Ivy	5+ All Round	N E S W	4 All Round	3.72	This tree is clad with ivy and dense vegetation both prevented a detailed inspection.	Fair	Fair	10-20	High	Ivy and vegetation to be cleared to enable a detailed inspection. / The client wishes to remove the tree and plant a more suitable species, if the development takes place.	High	1	C2 /U
	Lombardy Poplar																
	<i>Populus Nigra</i>																
T23	Mature Sessile Oak	17.6	4	65# over Ivy	4.2 East onto Site	N E S W	E 6.0	7.8	There is dense vegetation and ivy cladding on this tree which is preventing a detailed inspection and also trash piled up. I could not get close to the tree.	Indeterminate	Indeterminate	40+	High	Ivy and vegetation to be cleared to enable a detailed inspection. / No action is required to facilitate the development.	High	1	B1
	<i>Quercus petraea</i>																
T24	Early mature Oak	16.5	6#	39#	6.5# East onto Site	N E S W	E 7.7	4.68	This tree is situated on adjacent land with no access permitted to take the measurements of the crown and to inspect all of the tree. I did note that the tree has a high crown.	Good	Good	40+	High	Enable access to perform a full inspection. / No action is required to facilitate the development.	High	1	B1
	<i>Quercus sp.</i>																
T25	Early mature Oak	16	5.3#	39#	5.1# N	N E S W	E 7.5#	4.68	This tree is situated on adjacent land with no access permitted to take the measurements of the crown and to inspect all of the tree. I did note that the tree has a high crown.	Good	Good	40+	High	Enable access to perform a full inspection. / No action is required to facilitate the development.	High	1	B1
	<i>Quercus sp.</i>																
T26	Mature Sessile Oak	21.8	4.5	66	5.8 W	N E S W	5.3 4.9 4.8 5.0	7.92	This is situated in the tarmac driveway by the fence in the front garden between the house and the car port. It has a large torn out branch on the eastern side at 5.8 metres leaving a short, thick stub.	Good	Good	40+	High	No action is required. / No action is required to facilitate the development.	n/a	5	B1
	<i>Quercus petraea</i>																
T27	Mature Common Beech	16.9	2.6	64	6.4 W	N E S W	5.4 7.9 7.0 7#	7.68	This beech tree has many small leaves. There is a cupboard door fracture and a big split going down the tree. There is also a dead branch on top of it. I categorise the tree as 'B' at present. This tree is T28 in TPO No.21 1985.	Fair	Poor	10-20	High	Reduce the limb which is causing the fracture by 33% so the wound can seal over - VERY HIGH PRIORITY. Monitor this annually - HIGH PRIORITY. / No action is required to facilitate the development.	Very High/ High	1	B1
	<i>Fagus sylvatica</i>																
T28	Early mature Sycamore	18.6	3.4	30#	None over the site	N E S W	0.0 6.9 8.0 6.7	3.6	This tree is situated on adjacent land close to the boundary (About 1 metre from the retaining wall) and is suppressed by T27. There is flush cut pruning with occluded growth and cavity formation. The tree blocks the cast of the street light. This tree is T26 in TPO No.21 1985.	Good	Fair	20-40	Mod	Inform the owners that the tree requires pruning to be clear of the streetlight. / No action is required to facilitate the development.	High	5	B1
	<i>Acer pseudoplatanus</i>																

## Appendix 3 – Protected Species

### Protected Species – Bats

Mature trees often contain cavities, crevices and hollows which are a potential habitat for roosting bats. Bats are afforded protection under Schedule 5 of the Wildlife and Countryside Act 1981 (as amended), as well as under Schedule 2 of the Conservation of Species and Habitats Regulations 2010, and as such causing damage to a bat roost constitutes an offence.

A preliminary ground level appraisal of the wildlife habitat value of each tree was undertaken as part of the arboricultural survey. There were no features suitable to support roosting bats.

Should the presence of a bat roost be suspected whilst undertaking works on any other trees and groups on site, operations must be halted until a licensed bat handler or ecologist can provide advice.

### Protected Species - Birds

Trees are a potential habitat for nesting birds, which (as well as their nests and eggs) are protected under the Wildlife and Countryside Act 1981 (as amended). This makes it an offence to intentionally or recklessly, damage or destroy an active birds nest or any part thereof.

Due to the suitability of the trees within the survey boundary for nesting birds, all tree work should ideally be undertaken outside the bird nesting season (British bird nesting season: primarily March to August inclusive).

Nonetheless, some bird species will nest outside of these months and a detailed inspection of each tree should be undertaken immediately prior to the arboricultural works being undertaken. Should an active nest be found (being built, containing eggs or chicks), then any work likely to affect the nest must be halted and resume only after the nest becomes inactive.

## Appendix 4 Technical Specification

# TECHNICAL RECOMMENDATION



**APPLICATION**  
[11 RUR-CEL]

**Reinforcement of Roads  
with Cellweb**

**PROJECT:**

**PROPOSED DETACHED DWELLING AT 27 CHURCH LANE**

**DESIGNER / SPECIFIER:**

**T J COATES LIMITED**

**Contact:**

**Mr. Paul Bailey**

**PLANNING AUTHORITY:**

**KIRKLEES COUNCIL**

**Reference:**

TR21-3644\_RUR\_CEL\_Driveway for  
New Dwelling at 27 Church Lane

**Version:**

V1

**Location:**

27 Church Lane, Mirfield,  
West Yorkshire, WF14 9HX

**Date:**

26 April 2021

## PROJECT DESCRIPTION

Proposed a new driveway for 27 Church Lane over a tree root protection zone with the use of Cellweb. The project is located at 27 Church Lane, Mirfield, West Yorkshire, WF14 9HX. Cellweb is a no dig tree root protection measure and it is recommended that no excavation be performed without prior approval and guidance from the tree officer.

This document TR21-3644\_V1 provides the preliminary calculation of the reinforced areas over Tree Root protection zone, according to email, questionnaire and information delivered by Mr. Paul Bailey on the 16/04/2021.

### ▪ **Ground conditions:**

- Soil Info: Granular (as per client details).
- CBR: Assumed 1.0% for calculation.
- **Total Area:** 215m<sup>2</sup> (measured from plan)

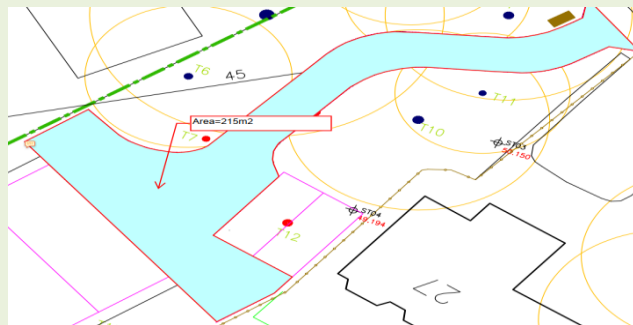

### ▪ **Traffic Information for Driveway:**

- Traffic design: Const. traffic up to 20ton (excavator telehandler and a standard dumper), Occasional fire, emergency vehicles
- Maximum Gross Vehicle Weight GVW = Max <20,000 kg
- Maximum axle load = 80 kN/axle.
- Maximum wheel load = 40 kN/wheel

- **Infill material for Cellweb:**
  - 4mm to 20mm clean angular stone, Type 4/20 due to tree root protection requirement. Specification according to BS7533-13
- **Surface After Construction:**
  - 50mm Loose Gravel: see overfill

## OBJECTIVE

To propose a technical solution of reinforcement using the minimum required thickness of subbase Type 4/20 and Cellweb TRP and non-woven Geotextile Treetex for separation.

Due to tree root protection requirements, the solution has to be a no-dig and no-compaction system to protect tree roots. The Cellweb TRP with subbase Type 4/20 provides a stable structure to distribute the loads and reduce the pressure at the ground level. The system promotes the migration of water and nutrients, maintaining the soil bulk density at levels that are suitable for tree root growth.

## DESIGN METHOD

The methodology used is based on the design methods of reinforcement of unpaved roads proposed by Webster (1981). The first step in the design of a Cellweb reinforced pavement is to consider the ultimate bearing capacity of the pavement system under the greatest wheel load that it will have to support. This is undertaken following the guidance provided by Webster which uses conventional bearing capacity analysis to determine the applied and allowable pressure below the road pavement. The equations were derived for unpaved road design and make no allowance for the surfacing over the Cellweb. They are therefore considered to be conservative when permanent surfacing is placed over the Cellweb reinforced sub-base.

When additional sub-base is required beneath Cellweb the depth of this material may be reduced by placement of surfacing material above. If the thickness of surfacing is equal to or greater than the required sub-base, then the sub-base may be omitted.

## PARAMETERS AND CONSIDERATIONS

In order to perform the calculations, we used the methodology for reinforcement of unpaved roads, not taking account of any permanent surfacing that may be provided.

Standards and Specifications according to application:

- BS5837:2012
- APN 12
- BS7533-13:2009 for infill material

In the following tables, we present the parameters and assumptions used for the preliminary calculation. All parameters need to be verified by the client for final design.

## SOIL PROPERTIES

### SUBGRADE SOIL

Soil Type:	Granular (as per client details)
CBR:	1.0% assumed for calculation
Undrained shear strength $C_u$ :	23 kPa
Internal friction angle, $\phi_u$ :	0 deg
Unit weight, $\gamma$ :	18 kN/m <sup>3</sup>

### FILL MATERIAL: CELLWEB AND SUBBASE

Soil Type:	Clean angular stone
Type BS7533-13:	Type 4/20
Internal friction angle, $\phi'_{pk}$ :	35 deg
Unit weight, $\gamma$ :	18 kN/m <sup>3</sup>
Particle size:	4 mm to 20 mm

## TRAFFIC DESIGN

	<b>Driveway</b>
Type of Traffic:	Const. traffic up to 20ton (excavator telehandler and a standard dumper), Occasional fire, emergency vehicles
Gross Vehicle Weight GVW:	< 20,000 kg
Max Axle load:	80 kN/axle
Wheel load, P:	40 kN/wheel
Tire inflation Pressure, p:	606.06 kPa

## SOLUTION OF DRIVEWAY OVER TREE ROOT PROTECTION AREA

<b>Construction:</b>	<b>Driveway</b>
<b>Surface:</b> (design by others accordingly to the appropriate standard)	50mm Loose gravel see overfill.
<b>Separation: Above overfill and beneath the surface</b>	N/A
<b>Overfill: above Cellweb: clean angular stone Type 4/20</b>	50mm Clean Angular Stone Type 4/20.
<b>Cellweb TRP: fill with 4 to 20mm clean angular stone Type 4/20:</b>	Cellweb TRP: 1 layer of 200mm Cellweb TRP
<b>Subbase: 4 to 20mm clean angular stone Type 4/20</b>	Structural purpose: 30mm clean angular stone type 4/20
	Installation purpose: variable subbase for levelling of foundation if required
<b>Separation: beneath Cellweb or Subbase</b>	1 layer of Geotextile Treetex

**Note: Loose Gravel surface:** Particle sizes, gradation and thickness to be specified by others according to the appropriate specification of the project.

Regular use will cause movement and displacement of granular particles, giving as a result superficial deformation (rutting) and settlement of the surface. Therefore, regular maintenance is very important when using loose gravel surface, including the replacement of gravel to keep the required minimum thickness of the surface.

## CROSS-SECTION OF DRIVEWAY WITH CELLWEB OVER TRP AREA

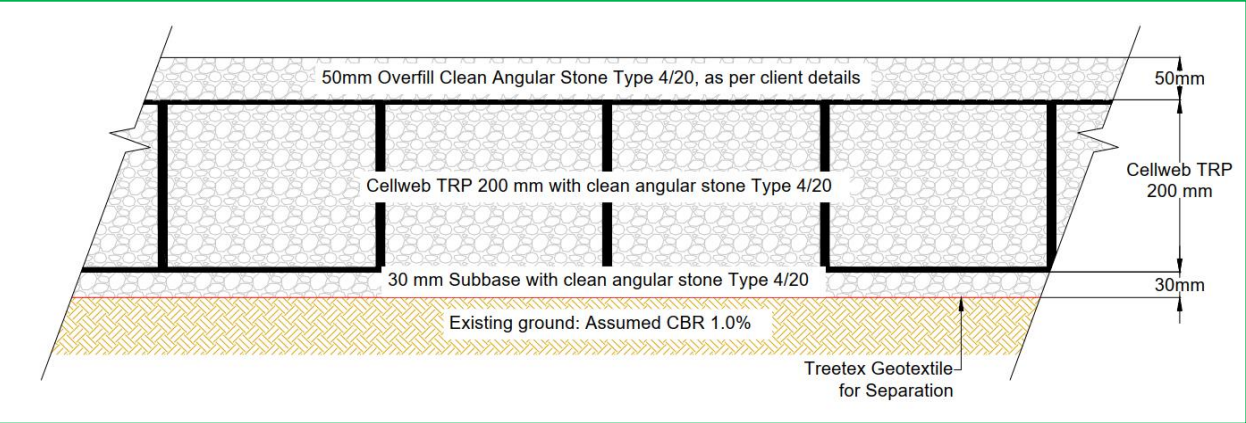

## RECOMMENDATIONS

**Granular Fill:** Clean angular stone Type 4/20. Please refer to BS7533-13:2009 and to the Design Manual for Roads and Bridges (DMRB), Volume 4 Geotechnics and Drainage, Section 1 Earthworks, HA44/91, Volume 7 – IAN 73/06 Design Guidance for road pavement foundations and Manual of Contract Documents for Highway Works (MCHW), Volume 1 Specification for Highway Works for the construction and maintenance of the fill material.

**Soil Properties:** All the properties of the soils have been assumed in order to perform the calculations. It is necessary to check the properties with the actual soil test results and the actual soils at the project site, so as to refine the calculations.

**Traffic information:** The traffic information has been extracted from the information sent by the client and the values have been assumed in order to perform the calculations. It is necessary to check the information with the actual traffic at the project site, so as to refine the calculations.

**Drainage systems:** Appropriate drainage systems need to be advised if applicable by the client/designer prior to final design. If drainage systems are required those needs to be designed and specified by others. Geosynthetics should be advised on the results of the drainage assessment, so it can be taking into account in the layout of the Cellweb System.

**Geotextile for separation:** we recommend the installation of a Non-Woven Geotextile Treetex under the Cellweb or under subbase if installed.

**Geotextile:** Overlapping between adjacent rolls of Geotextile: CBR > 3%: 300mm minimum, CBR between 1% and 3%: 500mm minimum, CBR ≤ 1%: 750mm minimum.

**Herbicide:** According to BS5837:2012 “The use of herbicides in the vicinity of existing trees should be appropriate for the type of vegetation to be killed, and all instructions, warnings and other relevant information from the manufacturers should be strictly observed and followed. Care should be taken to avoid any damaging effects upon existing plants and trees to be retained, species to be introduced, and existing sensitive habitats, particularly those associated with aquatic or drainage features.”

### Loose Gravel surface during construction phase:

Regular use will cause movement and displacement of granular particles, giving as a result superficial deformation (rutting) and settlement of the surface. Therefore, regular maintenance is very important when using loose gravel surface, including the replacement of gravel to keep the required minimum thickness of the surface.

## CONTACT INFORMATION

For further information, please contact our technical department



**Geosynthetics Ltd.**  
Fleming Road  
Harrowbrook Industrial Estate  
Hinckley, Leicestershire LE10 3DU  
Tel : 01455 617139 Fax 01455 617140  
sales@geosyn.co.uk  
www.geosyn.co.uk

### DISCLAIMER

Any calculations produced by us for you are provided for your assistance only and do not constitute any warranty as to fitness for purpose of any of our products in respect of any specific construction. It is your responsibility to determine the suitability of our products within a particular construction.

Our calculations are based entirely on the information provided by you and/or any assumptions made by us in good faith. We shall not be liable to you, whether in contract, tort (including negligence), breach of statutory duty, or otherwise, for any loss arising in consequence of incorrect, inaccurate or incomplete information provided to us by you or arising as a consequence of reasonable assumptions made by us in good faith.

Any advice (including any calculations) that we give to you in any form is provided solely for your own use and we shall not be liable to any third party, whether in contract, tort (including negligence), breach of statutory duty, or otherwise, for any loss arising as a result of or in connection with such advice.

## Appendix 5 Generic Installation Method

# Cellweb® TRP Installation Guide



Step 1: Prepare Surface



Step 2: Lay out Treetex™



Step 3: Lay out Cellweb® TRP

- Cellweb® TRP is a NO DIG tree root protection measure and it is recommended that no excavation be performed without prior approval and guidance from the Local Authority Arboricultural Officer.
- Soil compaction from vehicles, machinery and materials is to be strictly prohibited during construction within Root Protection Areas (RPAs).
- Approval must be obtained from the Local Authority that the design and the method of construction is acceptable.
- Further information is available from the following two documents;
  - British Standard BS5837: 'Trees in Relation to Design, Demolition and Construction' (2012).
  - Arboricultural Advisory and Information Service: Practice note 12 – 'Through the Trees to Development' (APN12).

## Installation Method

### 1. Prepare the Surface

- Remove the surface vegetation using appropriate hand held tools or herbicide (see Note 1).
- Remove any surface rocks, debris and organic material.
- Create a level surface by filling any hollows with clean angular stone or sharp sand.
- Do not level off high spots or compact the soil through rolling.

### 2. Lay out the Treetex™ Non-Woven Geotextile

- Lay out the Treetex™ over the prepared area, overlaying the edges of the required area by 300mm.
- Overlap any joins by 300mm minimum or more, depending on soil structure (see Note 2).

### 3. Lay out the Cellweb® TRP Cellular Confinement System

- Lay out the collapsed Cellweb® TRP on-top of the Treetex™.
- Place one of the supplied J pins into the centre cell at the end of the panel and secure into the ground.

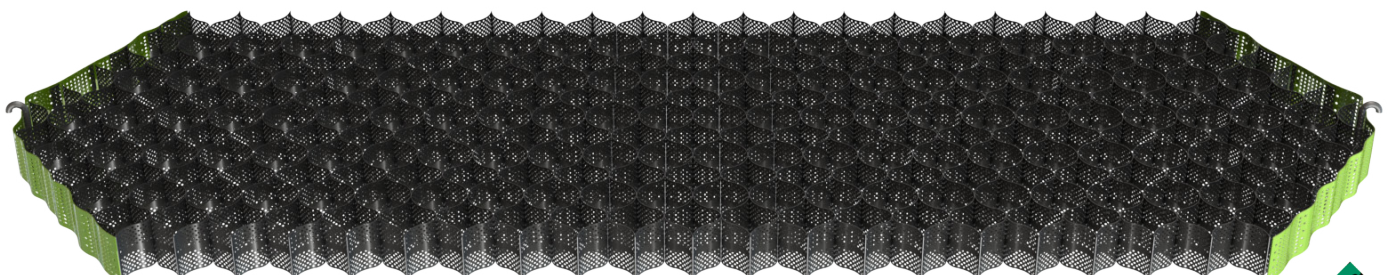

# Cellweb® TRP - Installation Guide



Step 3: Pinning Cellweb® TRP



Step 3: Stapling Cellweb® TRP

- Pull out the Cellweb® TRP to its full 8.1m length and secure its length with another J pin.

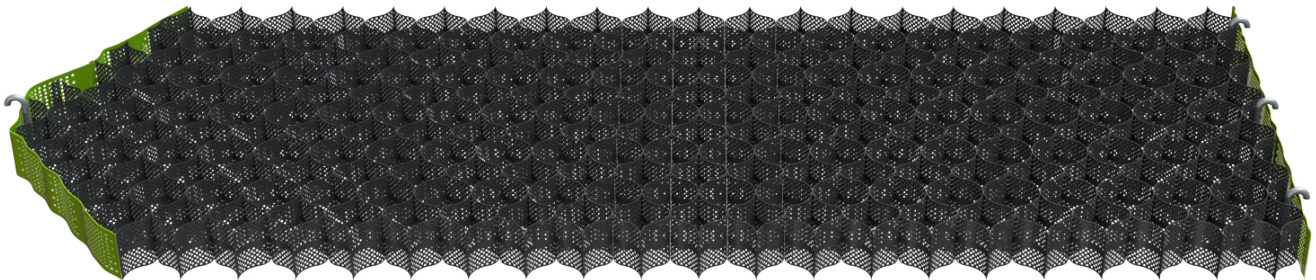

- Now measure its width to 2.56m and secure in each of the corners with the J pins.
- Use 10 pins per panel to create a panel measuring 8.1m x 2.56m.

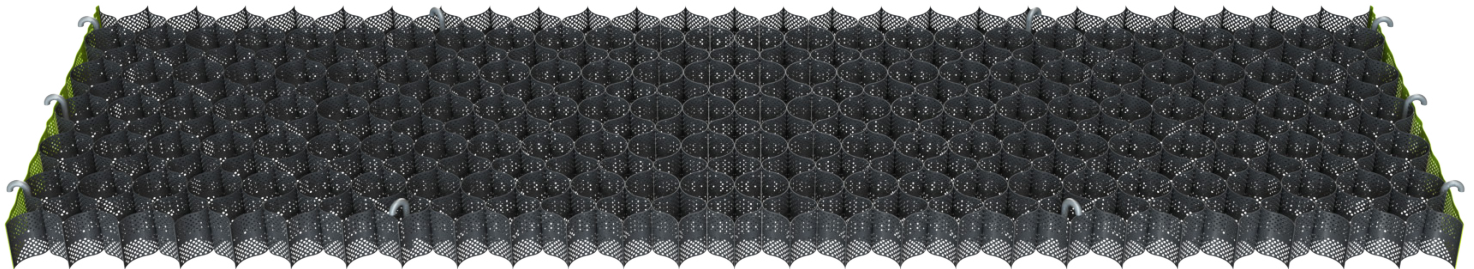

- This will produce a cell size of 259mm x 224mm which is the required cell diameter. Each cell must be fully extended and under tension.
- Staple adjacent panels together at each cell (see Note 3).
- If a curved path or shape is required, this should be cut when the Cellweb® TRP panel is pinned out to 8.1 x 2.56m, ensuring complete cells remain. Do not try to curve or bend the Cellweb® TRP panels into place.
- All cells must be fully opened to the required diameter.

# Cellweb® TRP - Installation Guide



Step 4: Clean Angular Stone



Step 5: Edge Restraints



Step 6: Surface Options

## 4. Infill the Clean Angular Stone

- The infill material must be a clean angular stone, Type 4/20mm or Type 20/40mm (see Note 4).
- Do not use M.O.T type 1 or crushed stone with fines for tree root protection.
- Infill the Cellweb® TRP cells with the clean angular stone, working towards the tree and using the infilled panels as a platform.
- Minimum 25mm overfill of clean angular stone.
- No compaction is required of the infill. Do not use a whacker plate or other means of compaction.

## 5. Edge restraints

- Excavations for kerbs and edgings should be avoided within the RPAs.
- Where edging is required for footpath and light structures, a peg and treated timber board edging is acceptable
- Other options include wooden sleepers, kerb edging constructed on-top of the Cellweb® TRP system, plastic and metal edging etc.

## 6. Surface options

- Surfaces can include block paving, asphalt, loose gravel, grass and gravel retention systems (eg Golpla™), resin bound gravel, concrete etc.
- For Root Protection Areas this surface must be porous.

## NOTES

- 1. Herbicide:** According to BS5837:2012 "The use of herbicides in the vicinity of existing trees should be appropriate for the type of vegetation to be killed, and all instructions, warnings and other relevant information from the manufacturers should be strictly observed and followed. Care should be taken to avoid any damaging effects upon existing plants and trees to be retained, species to be introduced, and existing sensitive habitats, particularly those associated with aquatic or drainage features."
- 2. Geotextile:** We recommend the installation of a Treetex™ under the Cellweb® TRP, or under the sub-base, if installed. The overlapping between adjacent rolls of Geotextile should be: CBR > 3%: 300mm minimum, CBR between 1% and 3%: 500mm minimum. CBR ≤ 1%: 750mm minimum.
- 3. Staples:** Number of staples per join: 200mm: 5 staples. 150mm: 4 staples. 100mm: 3 staples. 75mm: 3 staples.
- 4. Granular Fill:** Open graded sub-base, clean angular stone Type 4/20 or Type 20/40. Please refer to BS7533-13:2009 and to the Design Manual for Roads and Bridges (DMRB), Volume 4 Geotechnics and Drainage, Section 1 Earthworks, HA44/91, Volume 7 – IAN 73/06 Design Guidance for road pavement foundations and Manual of Contract Documents for Highway Works (MCHW), Volume 1 Specification for Highway Works for the construction and maintenance of the fill material.

Produced by:

Date 19<sup>th</sup> May 2021



One World Arboriculture Ltd  
2-4 Southgate, Elland, West Yorkshire, HX5 0BW.

W: [www.oneworldarboriculture.co.uk](http://www.oneworldarboriculture.co.uk)

**Services we offer:**

**Reports**

- ✓ **Development** – Tree Constraints Plans, Arboricultural Impact Assessments, Method Statements and Site Supervision
- ✓ **Tree Condition** – Risk Assessments, Tree Hazard analysis, Tree Health Care
- ✓ **Tree Planting Schemes**
- ✓ **Mortgage**
- ✓ **Insurance**
- ✓ **Subsidence**

**Talks and Tours**

- ✓ **Tree Safety - Your duty as a Tree Owner / Manager**
- ✓ **Tree Identification**
- ✓ **Environmental Education**