

SITE PLAN (1:250)

KEY - Boundary treatment

- ① 1800mm high vertical close boarded timber fence with concrete posts and 300mm concrete gravel boards as required inc 1800mm high matching gate where indicated
- ② 1800mm high feature wall with 1903 mm high brick piers & Timber infill panel
- ③ Existing 950mm high stone dwarf wall (re-built)

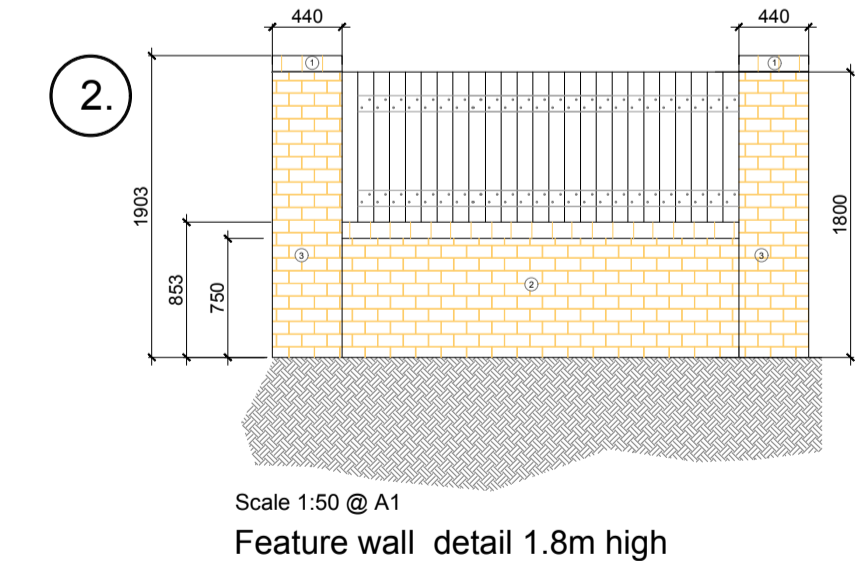
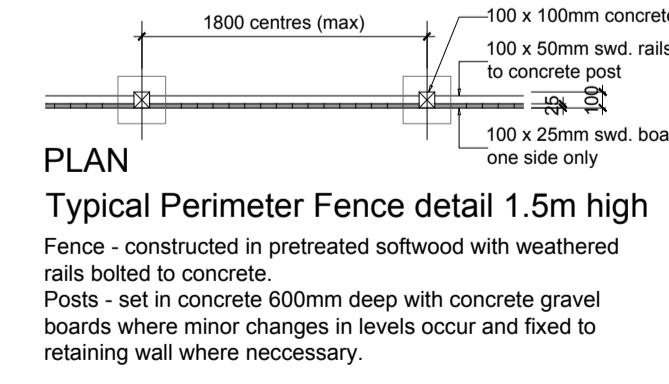
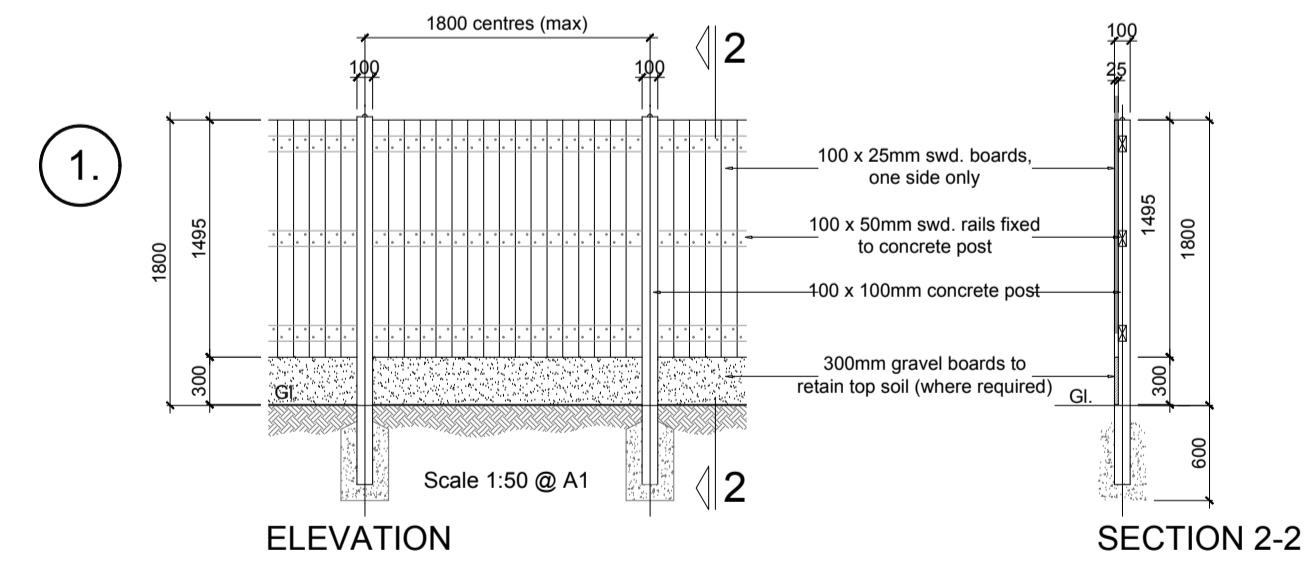

- 1. Stone on edge capping
- 2. 215 mm stone dwarf wall
- 3. 440 mm stone piers
- 4. Foundation to Structural Eng Design
- 5. Close board timber infill panel

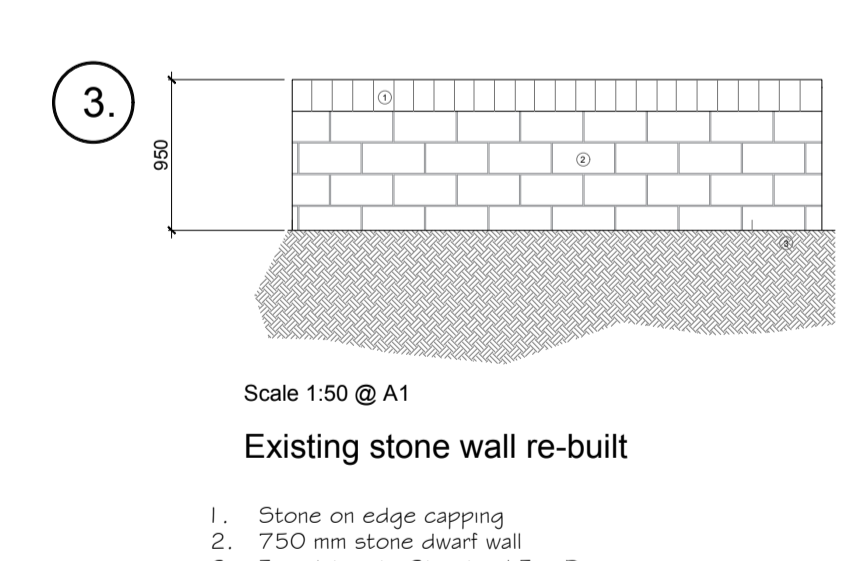

- 1. Stone on edge capping
- 2. 750 mm stone dwarf wall
- 3. Foundation to Structural Eng Design



BELMONT HOUSE
 2 DALTON COURT
 COMMERCIAL ROAD
 DARWEN
 BB3 0DG

project title:
**RESIDENTIAL DEVELOPMENT
 UNION STREET
 HECKMONDWIKE**

drawing title:
**BOUNDARY TREATMENT
 PLAN**

issue stage:

date: 01/07/19 drawn: A.H scale @ A1 1:250/1:50

drawing number: BAK-US-BTP revision: