



## TRANSPORT ASSESSMENT

### LAND OFF RAVENSTHORPE ROAD, DEWSBURY

Client: Miller Homes



**i-Transport**



## **TRANSPORT ASSESSMENT**

**LAND OFF RAVENSTHORPE ROAD, DEWSBURY**

**Client: Miller Homes**

i-Transport LLP  
Park House  
Park Square West  
Leeds  
LS1 2PW  
Tel: 0113 357 1360  
Fax: 0113 357 1361  
[www.i-transport.co.uk](http://www.i-transport.co.uk)

i-Transport Ref: SE/GJ/JO/dc/ITY11390-001A R

Date: 30 November 2016

### **COPYRIGHT**

The contents of this document must not be copied or reproduced in whole or in part without the written consent of i-Transport LLP

## QUALITY MANAGEMENT

<b>Report No.</b>	<b>Comments</b>	<b>Date</b>	<b>Author</b>	<b>Authorised</b>
ITY11390-001 R	Draft	18/11/2016	Jonathan Orton	Greg Jones
ITY11390-001A R	Issue	30/11/2016	Jonathan Orton	Greg Jones

File ref: L:\PROJECTS\11390\ITY Land off Ravensthorpe Road, Dewsbury\Admin\Report and Tech Notes\ITY11390-001A R -  
Transport Assessment.docx

## CONTENTS

SECTION 1	INTRODUCTION .....	1
SECTION 2	TRANSPORT POLICY CONTEXT .....	4
SECTION 3	SUSTAINABLE TRANSPORT PROVISION AND SITE ACCESSIBILITY .....	7
SECTION 4	EXISTING HIGHWAY CONDITIONS.....	13
SECTION 5	DEVELOPMENT PROPOSALS .....	22
SECTION 6	TRAFFIC IMPACT METHODOLOGY.....	25
SECTION 7	DEVELOPMENT TRAFFIC IMPACT ASSESSMENT .....	30
SECTION 8	CUMULATIVE ASSESSMENT .....	36
SECTION 9	CONCLUSIONS .....	45

## FIGURES

FIGURE 1.1	SITE LOCATION PLAN
FIGURE 3.1	KEY FACILITIES PLAN
FIGURE 4.1	2016 SURVEY TRAFFIC FLOWS
FIGURE 6.1	2021 TRAFFIC FLOWS
FIGURE 6.2	COMMITTED DEVELOPMENT DISTRIBUTION
FIGURE 6.3	COMMITTED DEVELOPMENT ASSIGNMENT
FIGURE 6.4	2016 BASE + COMMITTED DEVELOPMENT TRAFFIC FLOWS
FIGURE 6.5	2021 BASE + COMMITTED DEVELOPMENT TRAFFIC FLOWS
FIGURE 6.6	DEVELOPMENT TRAFFIC DISTRIBUTION
FIGURE 6.7	DEVELOPMENT TRAFFIC ASSIGNMENT
FIGURE 6.8	2016 BASE + COMMITTED + DEVELOPMENT TRAFFIC FLOWS
FIGURE 6.9	2021 BASE + COMMITTED + DEVELOPMENT TRAFFIC FLOWS
FIGURE 8.1	LEES HALL ROAD DEVELOPMENT TRAFFIC
FIGURE 8.2	2016 BASE + COMMITTED + CUMULATIVE DEVELOPMENT TRAFFIC FLOWS
FIGURE 8.3	2021 BASE + COMMITTED + CUMULATIVE DEVELOPMENT TRAFFIC FLOWS

## APPENDICES

APPENDIX A	ILLUSTRATIVE MASTERPLAN
APPENDIX B	SCOPING NOTE AND SCOPING RESPONSE
APPENDIX C	BUS MAP AND BUS TIMETABLE INFORMATION
APPENDIX D	PUBLIC RIGHTS OF WAY PLAN
APPENDIX E	CYCLE MAP
APPENDIX F	TRAFFIC, QUEUE AND ATC SURVEY DATA
APPENDIX G	BASE JUNCTION CAPACITY ASSESSMENTS OUTPUTS
APPENDIX H	PERSONAL INJURY ACCIDENT DATA
APPENDIX I	SITE ACCESS ARRANGEMENTS
APPENDIX J	TRICS OUTPUTS
APPENDIX K	CENSUS DATA DISTRIBUTION
APPENDIX L	PRINCIPAL JUNCTION CAPACITY ASSESSMENT OUTPUTS
APPENDIX M	SENSITIVITY TEST JUNCTION CAPACITY ASSESSMENT OUTPUTS
APPENDIX N	CUMULATIVE DEVELOPMENT JUNCTION CAPACITY ASSESSMENT OUTPUTS
APPENDIX O	CUMULATIVE DEVELOPMENT SENSITIVITY TEST JUNCTION CAPACITY ASSESSMENT OUTPUTS

## **SECTION 1 INTRODUCTION**

### **1.1 Background**

1.1.1 i-Transport LLP has been commissioned by Miller Homes to produce a Transport Assessment (TA) in support of an outline planning application for up to 120 residential dwellings on land south of Ravensthorpe Road in Dewsbury. All matters are reserved for future determination with the exception of means of access.

1.1.2 The site is located circa 2.5km to the southwest of Dewsbury town centre and is allocated for residential development in the adopted Kirklees Unitary Development Plan (UDP). An illustrative masterplan has been prepared for the site by Spawforths and is included at **Appendix A**.

1.1.3 Means of access is proposed via the creation of a new simple priority T-junction on Ravensthorpe Road at the western end of the site.

1.1.4 Miller Homes is concurrently submitting a separate outline planning application for further residential development on land identified as Provisional Open Land in the adopted UDP south of Lees Hall Road.

1.1.5 This Transport Assessment (TA) considers the accessibility of the Ravensthorpe Road site by a range of sustainable travel modes and demonstrates that the proposed access arrangements are safe and suitable for the site and can accommodate the forecast traffic levels. The TA concludes that the traffic generated by the development proposals, both in isolation and in combination with the development proposed at Lees Hall Road, would not result in a severe residual impact upon the external highway network.

1.1.6 A separate Framework Travel Plan (i-Transport Reference: ITY11390-002 R) has been produced in support of this application.

### **1.2 Site Location**

1.2.1 The site is located in the Ravensthorpe area of Dewsbury. Figure 1.1 illustrates the site location in the context of the surrounding highway network.

1.2.2 Dewsbury town centre is located approximately 2.5km to the northeast of the site. It provides a range of existing facilities catering for the principal journey purposes and needs of future residents.

### 1.3 Scoping

1.3.1 The scope of this TA has been discussed with Kirklees Council. A scoping email was issued to Highways Development Control officers at Kirklees Council on 12 September 2016 (please refer to **Appendix B**). The scoping email outlined the anticipated vehicular trip generation of the development proposals, proposed trip distribution and assignment parameters and the proposed study area for traffic assessment, as well as a preliminary representation of the proposed site access arrangements.

1.3.2 Kirklees Council issued a scoping response on 22 September 2016. It confirmed that the proposed site access arrangement is acceptable in principle and advised on key assessment parameters including Committed Development to be considered as part of the traffic assessment. The Council's scoping response is also included at **Appendix B**.

### 1.4 Report Structure

1.4.1 The remainder of this TA is structured as follows:-

- Section 2 presents a concise review of the policy context within which the application is submitted;
- Section 3 outlines the sustainable transport provision within the vicinity of the site including walking, cycling and public transport networks, and reviews the accessibility of the site by sustainable modes and its proximity to key facilities and services;
- Section 4 examines existing highway conditions within the vicinity of the site including a description of the surrounding highway network, existing traffic flows, baseline junction capacity assessments and recent personal injury accident data history;
- Section 5 describes the development proposals including the proposed access arrangements;

- Section 6 provides details of the traffic impact methodology, travel movements generated by the proposed residential development and how the forecast traffic levels will be distributed and assigned across the highway network. This section also includes information pertaining to the committed development considered in the assessment;
- Section 7 assesses the traffic impact of the development. This section presents operational assessments at the proposed site access junction and at off-site junctions across the agreed study area;
- Section 8 presents an assessment of the cumulative impacts of the development in combination with residential development at the Lees Hall Road site; and
- Section 9 draws together a summary of the report and presents our conclusions.

## SECTION 2 TRANSPORT POLICY CONTEXT

### 2.1 Introduction

2.1.1 This section briefly considers the policy context within which the application should be determined. A full review of the planning policy context related to the site is set out in the Planning Statement prepared by Spawforths.

### 2.2 National Planning Policy Framework (NPPF)

2.2.1 The specific transport policies of the NPPF are contained within Section 4 of the document. Paragraph 32 sets out the key 'tests' for the consideration of the transport aspects of development, noting that:

**'All developments that generate significant amounts of movement should be supported by a Transport Statement or Transport Assessment. Plans and decisions should take account of whether:**

- **the opportunities for sustainable transport modes have been taken up depending on the nature and location of the site, to reduce the need for major transport infrastructure;**
- **safe and suitable access to the site can be achieved for all people; and**
- **improvements can be undertaken within the transport network that cost effectively limit the significant impacts of the development. Development should only be prevented or refused on transport grounds where the residual cumulative impacts of development are severe.'**

2.2.2 Paragraph 36 notes the importance of Travel Plans, stating:

**'A key tool to facilitate this will be a Travel Plan. All developments which generate significant amounts of movement should be required to produce a Travel Plan.'**

### 2.3 The Development Plan

#### New Local Plan – Publication Draft

2.3.1 Kirklees Council is currently consulting on the soundness of its new Local Plan and an Examination in Public is expected to take place in Summer 2017.

2.3.2 The Council is proposing to allocate a strategic development option, identified within the emerging Local Plan as site H2089 'Land to the South of Ravensthorpe Road, Thornhill Lees, Dewsbury'.

2.3.3 The Publication Draft Local Plan identifies the above site, which encompasses both this application site and that off Lees Hall Road for which outline planning consent is concurrently being sought by Miller Homes, as having a capacity of 4,000 residential dwellings, with 2,310 of these delivered within the plan period.

2.3.4 The Publication Draft Local Plan's vision for Kirklees, which has influenced the proposed site allocations, notes:-

**'People will have access to a range of local facilities including services, health-care and education provision, and adequate infrastructure. Places will be well-connected encouraging sustainable travel including increased opportunities for walking and cycling and improved links to other parts of the Leeds City Region and beyond.'**

2.3.5 Furthermore, Draft Policy DLP20 notes the following regarding sustainable travel:-

**'New development will be located in accordance with the spatial development strategy to ensure the need to travel is reduced and that essential travel needs can be met by forms of sustainable transport other than the private car. The council will support development proposals that can be served by alternative modes of transport such as public transport, cycling and walking and in the case of new residential development is located close to local facilities.'**

**The council will support demand management measures which discourage single occupancy car travel within new development and encourage the use of low emission vehicles to improve areas with low levels of air quality. Proposals should include measures to encourage the use of sustainable travel options, including public transport, the promotion of personal journey planning, walking, cycling, car sharing and electronic communication and home working.'**

**Travel plans will be required for all major planning applications in accordance with current guidance and should set targets and monitoring arrangements to ensure sustainable travel patterns are maintained. Travel plans should include agreed and defined outcomes related to a package of specified measures to be implemented'.**

2.3.6 Thus the Council anticipates the use of sustainable travel modes for significant development allocations/proposals and the supporting policy justification text confirms this is expected to reduce traffic flows.

### Unitary Development Plan (UDP) Saved Policies

- 2.3.7 Until the new Local Plan is deemed sound and has been adopted, the UDP remains the Council's current adopted planning policy. A saved policies document was produced in 2007. The application site forms the western part of Site H10-5, which is allocated for housing. The whole of site H10-5 is some 13.1ha and the Council estimates an indicative capacity of 328 residential units across that area.
- 2.3.8 Therefore, the site is considered suitable for housing by Kirklees Council in both the currently adopted UDP and the emerging 'New Local Plan'.
- 2.3.9 The following saved transport policies are considered relevant to the determination of the application: T10 and T16.
- 2.3.10 Policy T10 notes that new development will not normally be permitted if it will create or materially add to highway safety or environmental problems or where it cannot be served adequately by the existing highway network and by public transport. It states that proposals will be expected to incorporate appropriate highway infrastructure designed to meet relevant safety standards and to complement the appearance of the development.
- 2.3.11 Policy T16 notes that new development should make provision for safe, convenient and pleasant pedestrian routes and safeguard the line of existing public rights of way by integration into the scheme or by diversion where a suitable alternative is available.

## SECTION 3 SUSTAINABLE TRANSPORT PROVISION AND SITE ACCESSIBILITY

### 3.1 Introduction

3.1.1 This section considers the existing sustainable transport provision within the vicinity of the site and appraises the accessibility of the site to a range of key services and facilities.

3.1.2 The Framework Travel Plan which accompanies this application sets out a range of measures designed to encourage sustainable travel patterns to/from and at application site. The Travel Plan will be implemented from the outset of the development to maximise the opportunities to influence travel patterns at the site.

### 3.2 Existing Public Transport Provision

3.2.1 The development site is located to take advantage of existing public transport services that operate in the vicinity of the site. Existing conditions are described below.

#### Bus Services

3.2.2 The closest bus stop to the site is located on Ouzelwell Lane, to the east of the site. This is approximately 700m from the centre of the site, which equates approximately to an 8-minute walk. This stop is served by the number 128 and 130 services, which serve Dewsbury and Wakefield. The stop takes the form of a simple flag; timetable information is displayed.

3.2.3 Table 3.1 summarises the local bus services in close vicinity of the site.

**Table 3.1: Local Bus Services**

Service	Route	Mon - Sat		Sunday	
		Day	Eve	Day	Eve
128 / 130	Wakefield - Dewsbury	Every 60 mins	-	-	-

3.2.4 Bus stops served by the 281/282 and 283 services are located further east on Lees Hall Road. In addition, regular bus services (205, 253, 262, 278 and Max 202/203) are available on A644 Huddersfield Road circa 1km north from the centre of the site. These routes provide services to Dewsbury, Huddersfield, Halifax and Leeds and are summarised below.

**Table 3.2: Additional Bus Services**

Stop Location	Route		Frequency			
			Weekday		Saturday	Sunday
			Daytime	Evening		
Huddersfield Rd- Union St	205	Dewsbury- Mirfield	60	-	60	-
	253	Dewsbury- Bradford Interchange	60	60	60	60
	262	Huddersfield- Dewsbury	30	-	30	60
	278	Halifax- Dewsbury	60	60	60	60
	Max 202/203	Huddersfield- Leeds	20	30	20	30
Lees Hall Rd	128/130	Dewsbury- Wakefield	60	-	60	-
	281/282	Fieldhead Estate - Thornhill	30	30	60	60
	283	Bradford- Thornhill	60	60	60	60

3.2.5 A bus map and bus timetable information is provided in **Appendix C**.

#### Rail Services

3.2.6 The closest railway station to the site is Ravensthorpe Station, which is situated approximately 600m from the centre of the site, equating to a circa 7-8 minute walk (assuming a walk speed of 1.4m/s or c. 5kph) or a 2-3 minute cycle from the site (assuming a cycle speed of c. 15kph). 10. no. uncovered cycle parking stands are provided at the Station.

3.2.7 Ravensthorpe Station provides connections to Leeds and Huddersfield as well as local destinations including Dewsbury, Batley, Morley and Mirfield.

3.2.8 Table 3.2 provides a summary of the rail services from Ravensthorpe Station.

**Table 3.2: Local Rail Services from Ravensthorpe Station**

Route	Mon - Sat			Sunday	
	Morning Peak	Off Peak	Evening	Day	Evening
Huddersfield-Ravensthorpe – Dewsbury – Batley – Morley – Leeds	Every 30 mins	1 per hour	1 per hour	1 every 2 hours	1 every 2 hours
Leeds-Ravensthorpe – Mirfield – Deighton - Huddersfield	1 per hour	1 per hour	Every 30 mins	1 every 2 hours	1 every 2 hours

3.2.9 Dewsbury rail station is located approximately 3km from the site and can be accessed via the 128/130 bus. Dewsbury Station provides connections to Liverpool, Hull, Scarborough and Manchester.

### 3.3 Walking and Cycling

3.3.1 Whilst superseded by the National Planning Policy Framework (NPPF), the transport policies set out in the former PPG13 set out specific guidance related to walking and cycling acceptable distances to local facilities. These distances also accord with the Institution of Highways and Transportation guidance on walking (Providing for Journeys on Foot) and the Department for Transport’s guidance on cycling (LTN 2/08 Cycle Infrastructure Design):

**‘Walking is the most important mode of travel at the local level and offers the greatest potential to replace short car trips, particularly under 2 kilometres’ (PPG13 - Para 74)**

and

**‘Cycling also has potential to substitute for short car trips, particularly those under 5 kilometres, and to form part of a longer journey by public transport’ (PPG13 - Para 77)**

3.3.2 These potential walking and cycling catchments have been used in the consideration of the accessibility of the site set out below.

### Pedestrian Network

- 3.3.3 Footways, ranging from approximately c.1.5m – 2.0m in width, are provided in the vicinity of the site along both sides of Ravensthorpe Road and on surrounding streets. These footways are street lit at regular intervals. There are no formal pedestrian crossing facilities on Ravensthorpe Road in the immediate vicinity of the site.
- 3.3.4 Ravensthorpe Road becomes Calder Road as it crosses the railway to the northwest of the site. The footway on the western side of the railway bridge is narrow but the eastern footway is sufficiently wide for pedestrians to pass one another.
- 3.3.5 A zebra crossing is provided across Lees Hall Road between Brewery Lane and Lees Holm to the northeast of the site.

### Public Rights of Way

- 3.3.6 There are a number of public rights of way (PROW) in the vicinity of the site.
- 3.3.7 To the west of the site, the footway along Ravensthorpe Road provides access to a bridleway, which provides a route adjacent to the railway towards Lady Wood and on towards Dewsbury Golf Course and other open countryside to the south west. A pedestrian bridge is also provided across the railway providing connections towards Mirfield.
- 3.3.8 A footpath is located further along Ravensthorpe Road adjacent to the River Calder providing access towards Dewsbury town centre and the footpath along the Calder and Hebble Navigation Canal. A bridleway is also provided to the east of the site adjacent to Ravenshall School and again providing connections to the countryside to the south west of the site.
- 3.3.9 A plan of the PROW in the vicinity of the site is provided in **Appendix D**.

### Cycling Network

- 3.3.10 National Cycle Route (NCR) 66 is located c.1.5km northeast of the centre of the site. It runs alongside the Calder and Hebble Navigation Canal, providing access to Dewsbury Country Park to the north west.

- 3.3.11 The Spen Valley Greenway uses a disused railway line running near the River Spen to link the towns of Cleckheaton, Dewsbury and Heckmondwike and ultimately links to Bradford.
- 3.3.12 NCR66 also provides a connection to NCR69 at the River Calder, which continues towards Dewsbury town centre.
- 3.3.13 Advisory cycle routes exist along the bridleways noted above and provide access through surrounding countryside (off-road).
- 3.3.14 These cycle routes are presented on the Dewsbury cycle map located in **Appendix E**.

#### 3.4 **Site Accessibility**

- 3.4.1 Figure 3.1 illustrates the key facilities within the vicinity of the site and identifies a 2km walking catchment, within which it is expected that walking (and/or cycling) could reasonably replace short car journeys.
- 3.4.2 The NPPF outlines that sustainable development can be achieved by providing housing with accessible local services that reflect the community's needs. There is a range of key facilities and services within the vicinity of the application site. The location of the nearest of each of the services is outlined in Table 3.4 below, together with details of the respective walking time / distance from the centre of the site. Where facilities are not within walking distance – i.e. beyond 2km - details of public transport connections are presented.

**Table 3.4: Accessibility of Local Services**

Category	Land Use	Name	Location	Distance (walk time)
Retail	Foodstore	Mullaco Supermarket	Slaithwaite Rd	2km (24 mins)
	Convenience	Kang Brothers	Lees Hall Road	750m (9mins)
Education	Primary School	Ravenshall School	Ravensthorpe Rd	550m (7mins)
		Headfield C of E Junior School	Vicarage Rd	1.6km (19 mins)
	Secondary School	Thornhill Community Academy	Valley Drive	3.3km (39 mins)*
Health	GP's	Thornhill Lees Medical Centre	Slaithwaite Rd	970m (12 mins)
	Pharmacy	Brewery Lane Pharmacy	Brewery Lane	1.4km (17 mins)
	Dentists	Thornhill Dental	Edge Lane	970m (12 mins)
Leisure	Various	Honeysuckle Park	Lees Hall Road	1.6km (19 mins)
		Thornhill Lees Community Centre	Brewery Lane	2.4km (29 mins)
Employment	Various	Industrial Estate off Forge Lane	Forge Lane	350-400m (4-5mins)

\* Accessible by Public Transport using bus services on A644 Huddersfield Road

3.4.3 In summary there are a large number of local destinations to the north and east of the site which can be accessed on foot within an acceptable distance. Existing bus stops and services can be used to access destinations further afield.

3.4.4 It is therefore concluded that the site is readily accessible to a large number of facilities and services by sustainable modes of transport.

### 3.5 Framework Travel Plan

3.5.1 A Framework Travel Plan has been prepared in support of the planning application (ref ITY11390-002 R). It builds upon the accessibility of the site through the formulation of Travel plan measures to encourage sustainable travel at the site from the outset of development.

## SECTION 4 EXISTING HIGHWAY CONDITIONS

### 4.1 Local Highway Network

#### Ravensthorpe Road

4.1.1 Ravensthorpe Road is a c.8.0m wide single carriageway road, which provides frontage access to existing residential development along much of its length. At its western end, Ravensthorpe Road also provides access to commercial and industrial premises including a Veolia waste facility. It is street lit at regular intervals and is subject to a 30mph speed limit. Traffic calming features are provided at regular intervals in the form of raised tables and speed cushions. There are no parking restrictions in the vicinity of the site.

4.1.2 Ravensthorpe Road connects to A644 Huddersfield Road via Calder Road to the west, and via Lees Hall Road, Forge Lane, Brewery Lane and the B6117 Slaithwate / Thornhill Road to the north and east.

#### Lees Hall Road

4.1.3 Lees Hall Road is a c.7.3m wide single carriageway road, which provides frontage access to existing residential development along much of its length. It too is street lit at regular intervals and is subject to a 30mph speed limit. Traffic calming features are again provided at regular intervals in the form of raised tables and speed cushions.

#### Forge Lane

4.1.4 Forge Lane connects Lees Hall Road with B6117 Station Road. It is a c.7.3m wide single carriageway road, again subject to a 30mph speed limit and is street lit at regular intervals. Continuous footways are provided on both sides of the carriageway. Forge Lane crosses over the canal and is bridged by the railway line. It provides access to various commercial premises.

### Calder Road

4.1.5 Calder Road is a continuation of Ravensthorpe Road, connecting Ravensthorpe Road to the A644 Huddersfield Road. Calder Road is subject to a 30mph speed limit and is street lit at regular intervals. Calder Road provides access to existing industrial areas on both sides of the carriageway, a small number of terraced housing is directly accessed off Calder Road towards its junction with the A644 Huddersfield Road.

4.1.6 Good quality footways are provided on both sides of the carriageway from the Railway bridge to the signal controlled junction at the A644 Huddersfield Road.

### B6117 Slaithwaite Road / Thornhill Road

4.1.7 The B6117 Slaithwaite Road / Thornhill Road provide a link from Thornhill Edge to the south east of the site to the A644 Huddersfield Road. Both the B6117 Slaithwaite Road and Thornhill Road are subject to 30mph speed limits and are street lit at regular intervals.

4.1.8 Between Thornhill Edge and the River Calder, the B6117 Slaithwaite Road mainly provides access to existing residential dwellings. To the north of the River Calder, Thornhill Road provides access to industrial and employment areas and a small number of existing residential dwellings.

4.1.9 Good quality footways are providing along both the B6117 Slaithwaite Road and Thornhill Road, with a number of pedestrian crossing facilities provided at regular intervals consisting of refuge island and zebra crossings.

## 4.2 **Baseline Survey Data**

4.2.1 A series of traffic surveys has been undertaken by independent specialists to inform the traffic analysis presented in this TA following scoping discussions with the Local Highway Authority. The surveys were undertaken on Tuesday 18 October 2016, during a 'neutral' traffic month as defined by the Design Manual for Roads and Bridges and within National Planning Policy Guidance, and outside of school holidays. No roadworks affected the surveys.

### Junction Turning Counts

4.2.2 The extent of the study area was agreed with Kirklees Council during scoping discussions. The following junctions were surveyed:

- i) Lees Hall Road / Brewery Lane mini-roundabout;
- ii) Lees Hall Road / Ravensthorpe Road / Forge Lane mini roundabout;
- iii) Ingham Road / Slaithwaite Road;
- iv) Forge Lane / Thornhill Road / Station Road double mini-roundabout; and
- v) Huddersfield Road / Calder Road signal-controlled junction.

4.2.3 The resultant peak hours were derived from the surveys as 0800 – 0900 in the AM peak and 1630 – 1730 in the PM peak. The full survey data is presented at **Appendix F**.

4.2.4 The observed 2016 survey traffic flows are shown on Figure 4.1.

#### Queue Surveys

4.2.5 Queue length surveys were undertaken at all junctions identified above and were undertaken at the same time as the junction turning counts. The full queue survey data is included within **Appendix F**.

4.2.6 The queue surveys identify a limited amount of queuing at the Lees Hall Road / Brewery Lane mini-roundabout, Lees Hall Road / Ravensthorpe Road / Forge Lane mini roundabout and the Ingham Road / B6117 Slaithwaite Road junction.

4.2.7 At the A644 Huddersfield Road / Calder Road signal-controlled junction, queues of c. 9 pcus were observed on the Huddersfield Road (east) and Calder Road arms in the AM peak. In the PM peak queues of c. 8 and 15 pcus were observed on the Huddersfield Road (east) and Calder Road arms respectively. However, as this junction provides access to a key route into Dewsbury this is not unexpected.

4.2.8 Queuing was also observed at the Forge Lane / Thornhill Road / Station Road double mini-roundabout junction.

### Automatic Traffic Count

4.2.9 An automatic traffic counter (ATC) was laid on Ravensthorpe Road in the vicinity of the proposed site access for a 7-day week from Tuesday 18 October 2016. The ATC recorded volumetric traffic flow data and vehicle speeds, the latter of which have been used to inform visibility splay requirements from the proposed site access junction. The full ATC data is also provided in **Appendix F**.

### 4.3 **Baseline Capacity Assessments**

4.3.1 Baseline junction capacity assessments have been undertaken at the junctions listed above. The calculation of the percentage impact / number of development trips at each junction is provided in Section 7.

4.3.2 Full details of the baseline junction capacity analyses are set out in **Appendix G**, including both model outputs and junction layout drawings. The results of the baseline assessments are summarised below.

### Lees Hall Road / Brewery Lane

4.3.3 The Lees Hall Road / Brewery Lane junction is a three arm priority controlled mini roundabout, with a pedestrian refuge island on Brewery Lane. The junction has been modelled using ARCADY software and a summary of the 2016 baseline junction capacity analysis is presented in Table 4.1.

**Table 4.1: Lees Hall Road / Brewery Lane 2016 Base Results**

Arm/Movement	AM Peak Hour		PM Peak Hour	
	Max RFC	Max Q (PCUs)	Max RFC	Max Q (PCUs)
Lees Hall Road (east)	0.38	1	0.28	0
Lees Hall Road (west)	0.25	0	0.27	0
Brewery Lane	0.12	0	0.13	0

RFC = Ratio of Flow to Capacity    Max Q = maximum average queue    PCUs = Passenger Car Units

4.3.4 The results show that the junction currently operates within capacity with a nominal amount of queuing observed at the junction, which is in line with the observed queue survey data.

Lees Hall Road / Ravensthorpe Road / Forge Lane

- 4.3.5 The Lees Hall Road / Ravensthorpe Road / Forge Lane junction is also a three arm priority controlled mini roundabout, with a pedestrian refuge island provided on Forge Lane. The junction has again been modelled using ARCADY software.
- 4.3.6 The results of the 2016 baseline junction capacity analysis are summarised in Table 4.2.

**Table 4.2: Lees Hall Road / Ravensthorpe Road / Forge Lane 2016 Base Results**

Arm/Movement	AM Peak Hour		PM Peak Hour	
	Max RFC	Max Q (PCUs)	Max RFC	Max Q (PCUs)
Lees Hall Road	0.53	1	0.36	1
Ravensthorpe Road	0.37	1	0.41	1
Forge Lane	0.35	1	0.42	1

RFC = Ratio of Flow to Capacity    Max Q = maximum average queue    PCUs = Passenger Car Units

- 4.3.7 The results show that the junction currently operates within capacity. Only a nominal amount of queuing is observed at the junction, in line with the observed queue surveys.

Ingham Road / Slaithwaite Road

- 4.3.8 The Ingham Road / Slaithwaite Road junction forms a priority controlled four-arm crossroads arrangement. A right turn ghost island is provided for approximately two vehicles turning into Ingham Road. A pedestrian refuge island is provided on the eastern side of the junction across Slaithwaite Road.
- 4.3.9 The junction has been modelled using the PICADY software and a summary of the 2016 base traffic survey results are presented in Table 4.3 below.

**Table 4.3: Ingham Road / Slaithwaite Road 2016 Base Results**

Arm/Movement	AM Peak Hour		PM Peak Hour	
	Max RFC	Max Q (PCUs)	Max RFC	Max Q (PCUs)
Slaithwaite Road (east)	0.00	0	0.00	0
Ingham Road – Left Turn	0.37	1	0.16	0
Ingham Road – Right Turn	0.71	2	0.54	1
Slaithwaite Road (west)	0.13	0	0.19	0
Hebble Court	0.03	0	0.03	0

RFC = Ratio of Flow to Capacity    Max Q = maximum average queue    PCUs = Passenger Car Units

4.3.10 The results show that the junction currently operates within capacity with a minimal amount of queuing occurring on the Ingham Road arm.

Forge Lane / Thornhill Road / Station Road double mini-roundabout

4.3.11 This junction forms a priority controlled four-arm double mini-roundabout, with the Thornhill Road arm forming a bridge over the River Calder. A zebra crossing is provided on Station Road approximately 50m to the north east of the junction.

4.3.12 The queue surveys contained within Appendix F recorded both spot queues on the minute and maximum queues within the minute. The surveys identify that the average spot queues in both peak hours are generally short, with the exception of the queue on Savile Road during the PM peak hour. Similarly, the average maximum queues are not particularly long either, again with the exception of Savile Road during the PM peak hour. However, the maximum queues recorded in the peak hours are significantly longer than the average (either spot or maximum) in nearly all cases, as demonstrated below:

**Table 4.4: Observed Queues at Forge Lane / Thornhill Road / Station Road double mini-roundabout**

Arm	AM Peak			PM Peak		
	Average Spot Q	Average Maximum Q	Max Q in peak hour	Average Spot Q	Average Maximum Q	Max Q in peak hour
Thornhill Road	3	7	18	6	15	40
B6049 Savile Road	2	5	17	17	31	41
Forge Lane	2	4	14	1	2	9
B6117 Station Road	1	8	34	1	4	22

Source: Queue surveys – Appendix F

4.3.13 The surveys identify some long queues but these generally last only for short periods within the peak hours, as evidenced by comparing the average spot / maximum queues with the absolute maximum queues.

4.3.14 In this context, whilst the junction has been modelled using ARCADY software, the base model summarised below in Table 4.5 does not replicate the observed queues. For example, the modelled queues in the AM peak hour far exceed the observed maximum queue on Thornhill Road, Forge Lane and Station Road. In the PM peak hour the modelled queue on Thornhill Lane far exceeds the observed maximum.

**Table 4.5: Forge Lane / Thornhill Road / Station Road 2016 Base Results**

Arm/Movement	AM Peak Hour		PM Peak Hour	
	Max RFC	Max Q (PCUs)	Max RFC	Max Q (PCUs)
B6117 Station Road	1.20	73	0.80	4
Forge Lane	1.39	57	0.85	5
Thornhill Road	1.57	65	1.39	119
B6409 Savile Road	0.72	3	0.82	4

RFC = Ratio of Flow to Capacity    Max Q = maximum average queue    PCUs = Passenger Car Units

4.3.15 The results show that the junction currently operates over capacity in both peak hours.

A644 Huddersfield Road / Calder Road Signal-controlled junction

4.3.16 The A644 Huddersfield Road / Calder Road three-arm signal-controlled junction forms the eastern part of the Dewsbury gyratory system.

4.3.17 It was agreed during scoping that the A644 Huddersfield Road / Calder Road could be considered in isolation from the remainder of the gyratory.

4.3.18 The junction has been modelled using the LINSIG software with the latest controller specification data supplied from Kirklees Council. Controlled pedestrian crossings are provided across the Huddersfield Road (east) and Calder Road arms. Stage 3 is demand dependent and from video observations the stage is only called three times in the AM peak and 12 times in the PM peak. Therefore, in the AM peak stage 3 has been excluded from the stage sequence and in the PM peak bonus green times have been added to the model to replicate the stage being called once every four cycles. A summary of the 2016 base traffic survey results are presented in Table 4.6.

**Table 4.6: Huddersfield Road / Calder Road 2016 Base Results**

Link	Arm/Movement	AM Peak Hour		PM Peak Hour	
		DoS (%)	MMQ (PCUs)	DoS (%)	MMQ (PCUs)
2/1	Huddersfield Road (East) - Left	71.2%	14	62.6%	11
2/2	Huddersfield Road (East) - Ahead				
3/1	Huddersfield Road (West) - Ahead	54.5%	1	56.2%	7
3/2	Huddersfield Road (West) - Right	69.8%	6	59.5%	5
4/1	Calder Road	72.3%	8	61.8%	6

DoS = Degree of Saturation    MMQ = Mean Maximum Queue    PCUs = Passenger Car Units

4.3.19 The results show that the junction currently operates within capacity. Queuing is experienced on all arms of the junctions. However, the amount of queuing is not considered to be significant and is broadly in line with the observed queue survey data.

#### 4.4 Personal Injury Accident Data

4.4.1 Personal injury accident data has been obtained from Leeds City Council, which is the authority responsible for the collation of such data across the City Region, including for Kirklees District.

4.4.2 Data for the most recently available five-year period (April 2011 – September 2016) has been obtained. Ten accidents have been recorded within the agreed study area during this period. The severity and location of the accidents is summarised in Tables 4.7 and 4.8 below.

**Table 4.7: Personal Injury Accident Data - Junctions**

Junction	Severity			
	Slight	Serious	Fatal	Total
Ravensthorpe Road / Lees Hall Road	1	1	0	2
Lees Hall Road / Forge Lane	3	0	0	3
Lees Hall Road / Brewery Lane	1	0	0	1

Source: Leeds City Council

**Table 4.8: Personal Injury Accident Data - Links**

Junction	Severity			
	Slight	Serious	Fatal	Total
Ravensthorpe Road	2	0	0	2
Lees Hall Road	1	1	0	2

Source: Leeds City Council

4.4.3 Two of the recorded accidents have been categorised as being of 'serious' severity. The other eight accidents are categorised as 'slight'.

4.4.4 One serious accident occurred on Lees Hall Road north-west of its junction with Ravensthorpe Road. The incident involved a van striking a child who had cycled onto the carriageway with the driver unsighted.

- 4.4.5 The second serious accident was recorded at the Ravensthorpe Road / Lees Hall Road junction occurred when a cyclist's rear wheel was clipped by a car causing the cyclist to lose control and fall.
- 4.4.6 The other (slight category) accident at the Ravensthorpe Road / Lees Hall Road involved a taxi performing a u-turn and colliding with the rear of another taxi.
- 4.4.7 Three of the accidents occurred at the Lees Hall Road / Forge Lane junction. Of these, two involved vehicle collisions with cyclists, whilst the third involved a collision between a car and a taxi as a consequence of one of the drivers failing to stop at the give-way line. The recorded data identify the following contributory factors for the accidents involving cyclists: the first notes that the affected cyclist was wearing dark clothing at night-time; the second identifies that the driver of a vehicle failed to look properly and did not notice the cyclist.
- 4.4.8 The slight category accident that occurred at Lees Hall Road / Brewery Lane involved a vehicle colliding with a cyclist as it negotiated the roundabout.
- 4.4.9 Two slight accidents occurred on Ravensthorpe Road. The first accident occurred when a vehicle was struck from the rear while stationary at temporary traffic signals. The second accident occurred when a car clipped a parked vehicle and lost control causing the car to roll onto its roof.
- 4.4.10 The final slight accident occurred on Lees Hall Road, west of its junction with Kimberley Street. It involved a collision between a car and a scooter. The records indicate that the driver of the car failed to look properly.
- 4.4.11 Overall, it is concluded that there is not an inherent road safety problem in the vicinity of the site which would require mitigation by these development proposals. A number of the reported accidents appear to have been caused by driver error. The traffic generated by the proposed development is not expected to have a significant detrimental impact on road safety. The raw data is presented at **Appendix H**.

## SECTION 5 DEVELOPMENT PROPOSALS

### 5.1 Introduction

5.1.1 The development will comprise up to 120 no. residential units, with access from Ravensthorpe Road.

5.1.2 An illustrative masterplan is reproduced at **Appendix A**. A proportion, anticipated to be circa 30%, of the dwellings will be affordable.

5.1.3 The final mix of dwelling types and sizes will be the subject of future reserved matters applications.

### 5.2 Means of Access

5.2.1 Vehicular, pedestrian and cycle access into the site is proposed via the creation of a new priority T-junction with Ravensthorpe Road.

5.2.2 The proposed access arrangements are shown in principle on Drawing ITY11390-GA-002A, included at **Appendix I**. The key elements of the proposed access arrangements can be summarised as follows:-

- Minor arm carriageway width = 7.3m (refer to sub-section 5.3 below).
- 2 x 2.0m wide footways tying into existing footways on Ravensthorpe Road.
- 6m radii at the junction.
- Dropped kerbs and tactile paving incorporated on the minor arm to facilitate safe east/west pedestrian movement.
- Visibility splay requirements in the horizontal plane have been derived using the Stopping Sight Distance (SSD) methodology set out in 'Manual for Streets' (MfS) and taking account of observed 85<sup>th</sup> percentile speeds from the Automatic Traffic Counter installed on Ravensthorpe Road:
  - Eastbound 85<sup>th</sup> percentile speed = 33.8mph
  - Visibility splay to west = 2.4m x 56.1m
  - Westbound 85<sup>th</sup> percentile speed = 28.7mph

- Visibility splay to east = 2.4m x 44.0m
- Visibility in the vertical plane achieves the requisite 0.6m x 2.0m envelope.
- Initial access gradients no steeper than 1:40 for the first 12.0m and 1:20 thereafter with suitable transition curves.
- Maximum gradient of 1:40 for the first 12m and

5.2.3 It is proposed to relocate the existing speed cushions on Ravensthorpe Road adjacent the site access junction circa 17m east of their current position. Doing so enables the introduction of dropped kerbs and tactile paving to provide an uncontrolled pedestrian crossing of Ravensthorpe Lane to serve the desire line to Ravensthorpe Station.

5.2.4 Drawing No. ITY11390-GA-003 - at **Appendix I** - presents swept path analyses of a Refuse Collection Vehicle (RCV) entering and exiting the proposed site access in forward gear.

5.2.5 The site access junction arrangement is capable of being converted at a future date to afford suitable access for a greater quantum of development, should the wider emerging allocation come about through the Local Plan process.

5.2.6 In addition to the main point of access into the site, the illustrative masterplan shows two retained pedestrian and cycle only accesses linking the site to Ravensthorpe Road. These links afford shorter connections to the bus stops on Lees Hall Road and a number of key services on Brewery Lane.

### 5.3 Internal Site Layout

5.3.1 This is an outline planning application and the internal site layout, as shown indicatively on the illustrative masterplan, will be a reserved matter.

5.3.2 The illustrative masterplan shows a spine road running adjacent the northern boundary of the site, with dwellings provided to the south of this. It is envisaged that the spine road within the site will be designed to a width that will not prejudice the potential ability to route bus services through the site in future, should the wider emerging allocation come about through the Local Plan process.

5.3.3 Within the site the illustrative street pattern illustrates a loop arrangement that provides route choice, as well as shared surfaces.

5.3.4 The illustrative site layout arrangements can be achieved in transport planning and highway engineering terms.

#### 5.4 **Refuse Collection**

5.4.1 Details of refuse collection arrangements within the site, including turning heads and locations of any bins stores or collection points will be a reserved matter.

#### 5.5 **Parking**

5.5.1 Car and cycle parking provision are reserved matters.

5.5.2 Parking will be provided in accordance with Kirklees Council's prevailing parking standards for residential developments and taking account of the requirements of the market.

5.5.3 The requirements for secure cycle parking within garages and/or in curtilage storage as appropriate will also be determined as part of Reserved Matters applications.

5.5.4 It is considered that there is ample space within the site to provide the necessary quanta of car and cycle parking.

## SECTION 6 TRAFFIC IMPACT METHODOLOGY

### 6.1 Introduction

6.1.1 This section sets out the traffic impact methodology used to assess the impact of the proposed development, including trip generation, distribution and assignment and assumptions regarding background traffic growth on the network. Details are also provided of the traffic associated with the committed development identified by Kirklees Council during pre-application scoping discussions.

6.1.2 The overall approach adds the development generated traffic to the forecast year base traffic flows. This approach is a worst case as it does not take account of potential future re-assignment of traffic as a result of changes in the demand and supply of transport.

### 6.2 Future Year Growth

6.2.1 The application site forms part of an emerging strategic development option identified within the emerging Local Plan as site H2089 'Land to the South of Ravensthorpe Road, Thornhill Lees, Dewsbury', which has been identified as having capacity to deliver 4,000 residential dwellings, with 2,310 of these delivered within the plan period.

6.2.2 The strategic development option will account for almost all of the future projected traffic growth in the vicinity of the site and will be the subject of detailed assessment (including the potential for re-assignment effects) and technical scrutiny by Kirklees Council in due course. In this context, application of growth to the surveyed 2016 traffic flows is considered unwarranted and the principal assessment presented below does not apply growth to the base traffic position.

6.2.3 Notwithstanding the above, a sensitivity test including background traffic growth has been conducted at the request of Kirklees Council using TEMPro. The sensitivity test assumes an Assessment Year of 2021 (i.e. application submission plus five years).

6.2.4 Kirklees Middle Super Output Area (MSOA) 017, 019, 023 and 024 have been used to establish the growth factors. The following factors have been applied to the 2016 survey data:

- AM Peak – 1.0681

- PM Peak – 1.0680

6.2.5 Figure 6.1 presents the factored 2021 traffic flows.

### 6.3 Committed Development

6.3.1 Kirklees Council has requested that traffic generated by the committed development of 169 no. residential dwellings at Forge Lane (LPA ref: 2013/92657) be included in the traffic assessment.

6.3.2 In the absence of a TA for the committed development at Forge Lane being available for reference, Kirklees Council has provided details of the agreed AM peak hour traffic generation as follows:-

- 24 arrivals; and
- 94 departures.

6.3.3 No information is available in respect of the PM peak hour traffic generation or the distribution and/or assignment of the traffic generated by the committed development.

6.3.4 As such, and for the purposes of the traffic assessment that follows, it has been assumed that the PM peak hour flow is the 'mirror' of the AM peak hour flows – i.e. 94 arrivals and 24 departures.

6.3.5 Traffic generated by the committed development has been distributed using 2011 Census journey to work data. The committed development distribution is shown in Figure 6.2 and the subsequent traffic assignment is shown in Figure 6.3.

6.3.6 The committed development assignment has been applied to the 2016 survey traffic is Figure 4.1 to produce a 2016 Base plus Committed Development scenario in Figure 6.4. The committed development scenario has also been applied to the 2021 Base traffic flows in Figure 6.1 to produce a 2021 Base plus Committed Development scenario in Figure 6.5.

## 6.4 Trip Generation

6.4.1 Multi modal trip generation rates have been derived from the latest version of the Trip Rate Information Computer System (TRICS) database to establish the anticipated trip generation of the proposed development.

6.4.2 The following selection criteria have been applied:-

- Multi-modal trip rates;
- Sites in England, excluding those located in Greater London;
- ‘Houses Privately Owned’ sub-category of the available residential uses;
- Sites between 100-500 dwellings included; and
- Sites located in suburban areas or edge of town locations.

6.4.3 The resultant vehicular trip rates are set out in Table 6.1:

**Table 6.1: Vehicular Trip Rates**

	AM Peak			PM Peak		
	Arr	Dep	2-Way	Arr	Dep	2-Way
Houses Privately Owned	0.122	0.357	0.479	0.311	0.197	0.508

Source: TRICS

6.4.4 The above vehicular trip rates are considered entirely appropriate for use in this assessment for the following reasons:

- i) The TRICS database is a nationally recognised industry leading tool for the derivation of trip rates to inform the assessment of development schemes;
- ii) The selection criteria applied are entirely consistent with the proposed development;
- iii) No adjustment has been made to the trip rates to take account of the affordable housing provision proposed on the site. Affordable housing generally exhibits a lower vehicular trip rate than does private market housing; and

- iv) The demographics of the local area lend themselves to lower levels of trip making including localised trip making, lower levels of car ownership, high bus and walk modal shares etc.

6.5 In this context it is concluded that the trip rates derived above are suitable for use in the assessment which follows.

6.5.1 The full TRICS outputs are included in **Appendix J**.

6.5.2 The anticipated traffic generation of the proposed development is summarised in Table 6.2:

**Table 6.2: Proposed Development – Traffic Generation**

	AM Peak			PM Peak		
	Arr	Dep	2-Way	Arr	Dep	2-Way
Vehicular Trip Rate	0.122	0.357	0.479	0.311	0.197	0.508
Generated trips (120 dwellings)	15	43	57	37	24	61

Source: TRICS

6.5.3 The development is therefore predicted to generate circa 60 two-way vehicle trips in either peak hour.

## 6.6 Trip Distribution and Assignment

### Trip Distribution

6.6.1 Traffic movements generated by the proposed development have been distributed across the agreed study area using 2011 Census travel to work data.

6.6.2 Data from origin Middle Super Output Areas (MSOAs) in Dewsbury close to the site were selected with destinations at local authority level. The overall distribution proportions at local authority level are as follows:-

**Table 6.3: Overall Journey to Work Trip Distribution**

Local Authority / Area	Percentage Proportion
Leeds	15.38%
Wakefield	11.38%
Bradford	4.95%
Calderdale	2.97%
Kirklees	59.79%
Other local authority areas	5.54%

Source: 2011 Census Data

- 6.6.3 The table shows that the majority of people (59.79%) travel to work within Kirklees and therefore the proportion of trips to and from this area have been further disaggregated into the respective Kirklees MSOAs to derive a more accurate distribution of trips made locally to the site.
- 6.6.4 The distribution of development generated trips is shown on Figure 6.6. The distribution only considers work journeys, evidenced by the Census. Consideration of other journey purposes would result in a changed distribution, reducing trips on the A644 Huddersfield Road to the west.
- 6.6.5 A full breakdown of the Census Data distribution is provided within **Appendix K**.
- 6.6.6 Trips were then assigned to destinations based on the fastest route derived from the current version of Google Maps.
- 6.6.7 The traffic flows generated by the proposed development are shown on Figure 6.7.
- 6.6.8 The proposed development flows have been applied to both the 2016 Base plus Committed Development (Figure 6.4) and 2021 Base plus Committed Development (Figure 6.5) scenarios to produce a 2016 Base plus Committed Development plus Proposed Development and a 2021 Base plus Committed Development plus Proposed Development scenario in Figure 6.8 and 6.9 respectively.

## **SECTION 7 DEVELOPMENT TRAFFIC IMPACT ASSESSMENT**

### **7.1 Introduction**

7.1.1 This section presents an assessment of the traffic impacts associated with the proposed development. It considers the change in traffic flows at junctions within the agreed study area with the proposed development in place. Junction capacity assessments are presented in those instances where the development is anticipated to result in either an increase in traffic of +5% of the total flows at the junction, or where it is anticipated to add more than 30 two-way trips in either peak hour.

7.1.2 A sensitivity test is also presented to include TEMPro background traffic projections.

7.1.3 The next section presents an assessment of the cumulative impact of the proposed development in combination with Miller Homes' proposed development at Land off Lees Hall Road.

### **7.2 Development Traffic Impact – Principal Assessment**

7.2.1 Table 7.1 presents a summary of the percentage impact of the development at each of the junctions within the study area.

7.2.2 This appraisal takes account of the percentage impact based upon existing traffic levels and the committed development outlined by Kirklees Council in the previous section.

**Table 7.1: Percentage Impact and number of two-way development trips**

	AM Peak Hour			PM Peak Hour		
	2016 Surveyed Flow + Committed Development *	Development Traffic	% Impact	2016 Surveyed Flow + Committed Development *	Development Traffic	% Impact
Lees Hall Road / Brewery Lane	656	11	1.7%	595	11	1.8%
Ingham Road / Slaithwaite Road	1766	8	0.5%	1732	5	0.3%
Lees Hall Road / Forge Lane / Ravensthorpe Road	1082	25	2.3%	1061	27	2.5%
Forge Lane / Station Road /Thornhill Road	2337	13	0.6%	2275	14	0.6%
Huddersfield Road / Calder Road	2614	41	1.6%	2333	39	1.7%

\* Total junction peak hour flow

7.2.3 From the above table, and based on the criteria identified above, it is concluded that the impact of the proposed development should be assessed in detail at the following junctions:

- Ravensthorpe Road / Proposed Site Access; and
- Huddersfield Road / Calder Road Signal Junction.

7.2.4 Operational assessment outputs for the principal assessment are included at **Appendix L**.

Ravensthorpe Road / Proposed Site Access

7.2.5 The proposed site access junction has been assessed using PICADY software. Table 7.2 presents the results of the '2016 Base plus Committed Development plus Proposed Development' traffic scenario:

**Table 7.2: Site Access / Ravensthorpe Road PICADY Results**

Arm/Movement	AM Peak Hour		PM Peak Hour	
	Max RFC	Max Q (PCUs)	Max RFC	Max Q (PCUs)
Site Access	0.11	0	0.06	0
Ravensthorpe Road – Right Turn	0.02	0	0.05	0

RFC = Ratio of Flow to Capacity    Max Q = maximum average queue    PCUs = Passenger Car Units

7.2.6 The assessment demonstrates that the proposed site access will operate within capacity and without discernible queuing.

Huddersfield Road / Calder Road Signal Junction

7.2.7 The baseline analysis presented in Section 3 demonstrates that the Huddersfield Road / Calder Road signal controlled junction currently operates within capacity with some queuing occurring at the junction.

7.2.8 Table 7.3 presents a summary of the junction capacity assessment results for the following scenarios:

- 2016 Base plus Committed Development; and
- 2016 Base plus Committed Development plus Proposed Development.

**Table 7.3: Huddersfield Road / Calder Road Results**

Link	Arm/Movement	2016 Base + Committed				2016 Base + Com + Dev			
		AM Peak Hour		PM Peak Hour		AM Peak Hour		PM Peak Hour	
		DoS (%)	MMQ (PCUs)	DoS (%)	MMQ (PCUs)	DoS (%)	MMQ (PCUs)	DoS (%)	MMQ (PCUs)
2/1	Huddersfield Road (East) - Left								
2/2	Huddersfield Road (East) - Ahead	73.9%	15	64.8%	12	75.6%	16	65.3%	12
3/1	Huddersfield Road (West) - Ahead	54.5%	1	56.2%	7	54.9%	1	64.6%	9
3/2	Huddersfield Road (West) - Right	64.4%	6	61.6%	6	62.2%	6	65.1%	6
4/1	Calder Road	71.7%	8	57.2%	6	73.1%	9	59.9%	6

DoS = Degree of Saturation      MMQ = Mean Maximum Queue      PCUs = Passenger Car Units

7.2.9 The results show that the Huddersfield Road / Calder Road signal controlled junction will continue to operate within capacity with the addition of committed development and the proposed development. A maximum queue increase of 2 pcu is experienced on Huddersfield Road (west) in the PM peak, with the additional proposed development traffic.

### 7.3 Development Traffic Impact – Sensitivity Test

7.3.1 The junction capacity assessments have been re-run with theoretical background traffic growth to a future Assessment Year of 2021 included.

7.3.2 Operational assessment outputs for the sensitivity test are included at **Appendix M**.

#### Ravensthorpe Road / Proposed Site Access

7.3.3 Table 7.4 presents the results of the ‘2021 Future Base plus Committed Development plus Proposed Development’ sensitivity test traffic scenario at the proposed site access:

**Table 7.4: Site Access / Ravensthorpe Road PICADY - Sensitivity Test Results**

Arm/Movement	AM Peak Hour		PM Peak Hour	
	Max RFC	Max Q (PCUs)	Max RFC	Max Q (PCUs)
Site Access	0.12	0	0.06	0
Ravensthorpe Road – Right Turn	0.02	0	0.05	0

RFC = Ratio of Flow to Capacity    Max Q = maximum average queue    PCUs = Passenger Car Units

7.3.4 The results show that the junction continues to operate well within capacity with no discernible queuing occurring at the junction.

7.3.5 It is concluded that the proposed site access arrangements are suitable.

#### Huddersfield Road / Calder Road Signal Junction

7.3.6 Table 7.5 presents the results of the '2021 Future Base plus Committed Development plus Proposed Development' sensitivity test traffic scenario at the Huddersfield Road / Calder Road signal junction:

**Table 7.5: Huddersfield Road / Calder Road – Sensitivity Test Results**

Link	Arm/Movement	2021 Base + Committed				2021 Base + Com + Dev			
		AM Peak Hour		PM Peak Hour		AM Peak Hour		PM Peak Hour	
		DoS (%)	MMQ (PCUs)	DoS (%)	MMQ (PCUs)	DoS (%)	MMQ (PCUs)	DoS (%)	MMQ (PCUs)
2/1	Huddersfield Road (East) - Left	78.9%	18	69.2%	13	80.7%	19	69.7%	13
2/2	Huddersfield Road (East) - Ahead								
3/1	Huddersfield Road (West) - Ahead	58.2%	1	60.0%	8	58.6%	1	60.3%	8
3/2	Huddersfield Road (West) - Right	68.4%	7	65.4%	6	66.3%	7	68.7%	7
4/1	Calder Road	76.3%	9	60.9%	7	77.2%	10	63.6%	7

DoS = Degree of Saturation    MMQ = Mean Maximum Queue    PCUs = Passenger Car Units

7.3.7 The results demonstrate that the addition of theoretical background traffic growth is not material to the operation of the junction which will continue to operate within capacity. The impact of the development does not have a material impact on the queuing at the junction, with a maximum increase in queuing of one pcu.

#### 7.4 **Summary**

- 7.4.1 In summary, the traffic flows associated with the proposed development are low and do not have a material impact on the surrounding highway network. This has been demonstrated through a proportional impact assessment and junction capacity testing.
- 7.4.2 The proposed new site access junction has been demonstrated to comfortably accommodate the proposed development traffic.
- 7.4.3 It is therefore concluded that the traffic flows generated by the proposed development will not have a severe impact in the context of the NPPF test.

## SECTION 8 CUMULATIVE ASSESSMENT

### 8.1 Introduction

8.1.1 Whilst this planning application relates to Miller Homes' development proposals at Land off Ravensthorpe Road in isolation, this section presents an assessment of the cumulative impact of the proposed development in combination with Miller Homes' other proposed development at Land off Lees Hall Road.

### 8.2 Cumulative Development Vehicular Trip Generation

8.2.1 The same vehicular trip rates as presented in Section 6 have been applied to the proposed development at Land off Lees Hall Road, which also seeks to bring forward up to 120 dwellings in outline.

8.2.2 Table 8.1 presents the cumulative trip generation of the two Miller Homes sites:

**Table 8.1: Cumulative Assessment Trip Generation**

	AM Peak			PM Peak		
	Arr	Dep	2-Way	Arr	Dep	2-Way
Vehicular Trip Rate	0.122	0.357	0.479	0.311	0.197	0.508
Land off Ravensthorpe Road (120 dwellings)	15	43	57	37	24	61
Land off Lees Hall Road (120 dwellings)	15	43	57	37	24	61
<b>Cumulative Proposed Development (240 dwellings)</b>	<b>30</b>	<b>86</b>	<b>114</b>	<b>74</b>	<b>48</b>	<b>122</b>

Source: TRICS

8.2.3 Traffic associated with the proposed development at Land off Lees Hall Road has been distributed across the agreed study area using the same distribution pattern as presented in this report. The resultant development generated traffic flows for the Lees Hall Road site are presented in Figure 8.1.

8.2.4 These flows have then been added to the '2016 Base plus Committed Development plus Proposed Development' flows (Figure 6.8) to provide '2016 Base plus Committed Development plus Cumulative Assessment flows' (Figure 8.2).

8.2.5 These flows have also been added to the '2021 Base plus Committed Development plus Proposed Development flows' (Figure 6.9) to provide '2021 Base plus Committed Development plus Cumulative Assessment flows' (Figure 8.3).

### 8.3 Cumulative Development Traffic Impact

8.3.1 Table 8.2 summarises the cumulative impacts of the two Miller Homes' sites at each of the junctions within the study area.

**Table 8.2: Percentage Impact and number of two-way development trips**

	AM Peak Hour			PM Peak Hour		
	2016 Surveyed Flow + Committed Development *	Cumulative Development Traffic	% Impact	2016 Surveyed Flow + Committed Development *	Cumulative Development Traffic	% Impact
Lees Hall Road / Brewery Lane	656	57	8.7%	595	61	10.3%
Ingham Road / Slaithwaite Road	1766	17	1.0%	1732	10	0.6%
Lees Hall Road / Forge Lane / Ravensthorpe Road	1082	46	4.3%	1061	49	4.6%
Forge Lane / Station Road / Thornhill Road	2337	38	1.6%	2275	40	1.8%
Huddersfield Road / Calder Road	2614	62	2.4%	2333	61	2.6%

\* Total junction peak hour flow

8.3.2 In combination, the two proposed Miller Homes schemes increase traffic flows at each of the off-site junctions within the study area by more than 30 two-way trips in the peak hours, with the exception of the Ingham Road / Salithwaite Road junction. As such, operational assessments have been conducted for each of the junctions except the Ingham Road / Salithwaite Road junction to confirm their performance in the following scenarios:

- 2016 Base plus Committed Development; and

- 2016 Base plus Committed Development plus Cumulative Development (240 dwellings).

8.3.3 Operational assessment outputs for the cumulative assessment are included at **Appendix N**.

Ravensthorpe Road / Proposed Site Access

8.3.4 Table 8.3 presents the results of the ‘2016 Base plus Committed Development plus Cumulative Proposed Development’ traffic scenario at the proposed site access junction:

**Table 8.3: Site Access / Ravensthorpe PICADY - Cumulative Assessment**

Arm/Movement	AM Peak Hour		PM Peak Hour	
	Max RFC	Max Q (PCUs)	Max RFC	Max Q (PCUs)
Site Access	0.11	0	0.06	0
Ravensthorpe Road – Right Turn	0.02	0	0.05	0

RFC = Ratio of Flow to Capacity    Max Q = maximum average queue    PCUs = Passenger Car Units

8.3.5 The results show that the addition of traffic generated by the proposed development at Land off Lees Hall Road does not materially affect the operation of the proposed site access junction.

Lees Hall Road / Brewery Lane Roundabout

8.3.6 Table 8.4 summarises the results of the ‘2016 Base plus Committed Development plus Cumulative Proposed Development’ traffic scenario at the Lees Hall Road / Brewery Lane roundabout.

**Table 8.4: Lees Hall Road / Brewery Lane ARCADY - Cumulative Assessment**

Arm/Movement	2016 Base + Committed				2016 Base + Committed + Cumulative Development			
	AM Peak Hour		PM Peak Hour		AM Peak Hour		PM Peak Hour	
	Max RFC	Max Q (PCUs)	Max RFC	Max Q (PCUs)	Max RFC	Max Q (PCUs)	Max RFC	Max Q (PCUs)
Lees Hall Road (east)	0.38	1	0.29	0	0.42	1	0.32	1
Lees Hall Road (west)	0.26	0	0.27	0	0.28	0	0.29	0
Brewery Lane	0.12	0	0.14	0	0.13	0	0.16	0

8.3.7 The Lees Hall Road / Brewery Lane roundabout will continue to operate within capacity with the addition of the cumulative development traffic.

Lees Hall Road / Ravensthorpe Road / Forge Lane

8.3.8 The baseline assessment presented in Section 4 demonstrates that the Lees Hall Road / Ravensthorpe Road / Forge Lane roundabout currently operates within capacity.

8.3.9 Table 8.5 summarises the results of the cumulative development test.

**Table 8.5: Lees Hall Road / Ravensthorpe Road / Forge Lane ARCADY - Cumulative Assessment**

Arm/Movement	2016 Base + Committed				2016 Base + Com + Cumulative Development			
	AM Peak Hour		PM Peak Hour		AM Peak Hour		PM Peak Hour	
	Max RFC	Max Q (PCUs)	Max RFC	Max Q (PCUs)	Max RFC	Max Q (PCUs)	Max RFC	Max Q (PCUs)
Lees Hall Road	0.55	1	0.37	1	0.58	1	0.40	1
Ravensthorpe Road	0.38	1	0.45	1	0.41	1	0.48	1
Forge Lane	0.40	1	0.44	1	0.41	1	0.45	1

RFC = Ratio of Flow to Capacity      Max Q = maximum average queue      PCUs = Passenger Car Units

8.3.10 The results show that the junction will continue to operate within capacity with minimal queuing. It is therefore concluded that this junction can accommodate the proposed cumulative development traffic.

Forge Lane / Thornhill Road / Station Road

8.3.11 The baseline assessment presented in Section 4 demonstrates that the junction operates over capacity. Nevertheless, the model has been used to assess the incremental impacts of the development proposals. It should however be noted that when a junction is shown to be operating over capacity the impacts of marginal changes in traffic flows (i.e. as a result of development generated traffic) will be worse than will occur in practice.

8.3.12 Table 8.6 summarises the results of the cumulative development test.

**Table 8.6: Forge Lane / Thornhill Road / Station Road ARCADY - Cumulative Assessment**

Arm/Movement	2016 Base + Committed				2016 Base + Com + Cumulative Development			
	AM Peak Hour		PM Peak Hour		AM Peak Hour		PM Peak Hour	
	Max RFC	Max Q (PCUs)	Max RFC	Max Q (PCUs)	Max RFC	Max Q (PCUs)	Max RFC	Max Q (PCUs)
B6117 Station Road	1.21	79	0.83	4	1.23	89	0.84	5
Forge Lane	1.54	93	0.87	5	1.57	103	0.89	6
Thornhill Road	1.55	65	1.46	148	1.54	66	1.50	164
B6409 Station Road	0.73	3	0.83	5	0.73	3	1.84	5

RFC = Ratio of Flow to Capacity      Max Q = maximum average queue      PCUs = Passenger Car Units

8.3.13 The results show that the addition of the committed development traffic results worsens the operation of the junction.

8.3.14 The impact of the cumulative development traffic at the junction, when compared to a situation already accepted by the Local Highway Authority, is not considered to be severe.

Huddersfield Road / Calder Road

8.3.15 Table 8.7 summarises the results of the '2016 Base plus Committed Development plus Cumulative Proposed Development' traffic scenario at the Huddersfield Road / Calder Road signal controlled junction.

**Table 8.7: Huddersfield Road / Calder Road Results – Cumulative Assessment**

Link	Arm/Movement	2016 Base + Committed				2016 Base + Com + Cumulative Development			
		AM Peak Hour		PM Peak Hour		AM Peak Hour		PM Peak Hour	
		DoS (%)	MMQ (PCUs)	DoS (%)	MMQ (PCUs)	DoS (%)	MMQ (PCUs)	DoS (%)	MMQ (PCUs)
2/1	Huddersfield Road (East) - Left								
2/2	Huddersfield Road (East) - Ahead	73.9%	15	64.8%	12	75.6%	16	66.5%	12
3/1	Huddersfield Road (West) - Ahead	54.5%	1	56.2%	7	54.9%	1	56.5%	7
3/2	Huddersfield Road (West) - Right	64.4%	6	61.6%	6	63.6%	6	65.1%	6
4/1	Calder Road	71.7%	8	57.2%	6	76.0%	10	58.7%	7

DoS = Degree of Saturation      MMQ = Mean Maximum Queue      PCUs = Passenger Car Units

8.3.16 The results show that the junction will continue to operate within capacity with the cumulative development with minimal increases to the queuing at the junction. The greatest increase in queuing is on the Calder Road arm in the AM peak where the queue increases by 2 pcus.

#### 8.4 Development Traffic Impact – Sensitivity Test

8.4.1 Again, and on a without prejudice basis, a sensitivity test has also been conducted applying background traffic growth to a future assessment year of 2021. The cumulative junction capacity assessments have been re-run with theoretical background traffic growth and a summary of the results are presented below.

8.4.2 Operational assessment outputs for the cumulative development sensitivity test are included at **Appendix O**.

#### Ravensthorpe Road / Proposed Site Access

8.4.3 Table 8.8 presents the results of the ‘2021 Future Base plus Committed Development plus Cumulative Development’ sensitivity test traffic scenario at the proposed site access:

**Table 8.8: Site Access / Ravensthorpe Road PICADY - Sensitivity Test Results**

Arm/Movement	AM Peak Hour		PM Peak Hour	
	Max RFC	Max Q (PCUs)	Max RFC	Max Q (PCUs)
Site Access	0.12	0	0.06	0
Ravensthorpe Road – Right Turn	0.02	0	0.05	0

RFC = Ratio of Flow to Capacity    Max Q = maximum average queue    PCUs = Passenger Car Units

8.4.4 The results show that the junction continues to operate well within capacity with no discernible queuing occurring at the junction, with the Ravensthorpe Road development traffic and the additional theoretical background traffic growth.

Lees Hall Road / Brewery Lane Roundabout

8.4.5 Table 8.9 presents the results of the ‘2021 Future Base plus Committed Development plus Cumulative Development’ sensitivity test traffic scenario at the Lees Hall Road / Brewery Lane mini-roundabout:

**Table 8.9: Lees Hall Road / Brewery Lane ARCADY Sensitivity Test Results**

Arm/Movement	2021 Base + Committed				2021 Base + Com + Cumulative Development			
	AM Peak Hour		PM Peak Hour		AM Peak Hour		PM Peak Hour	
	Max RFC	Max Q (PCUs)	Max RFC	Max Q (PCUs)	Max RFC	Max Q (PCUs)	Max RFC	Max Q (PCUs)
Lees Hall Road (east)	0.41	1	0.31	1	0.45	1	0.34	1
Lees Hall Road (west)	0.28	0	0.29	0	0.30	0	0.31	1
Brewery Lane	0.13	0	0.14	0	0.14	0	0.17	0

RFC = Ratio of Flow to Capacity    Max Q = maximum average queue    PCUs = Passenger Car Units

8.4.6 The results demonstrate that the addition of theoretical background traffic growth is not material to the operation of the junction which will continue to operate within capacity and without a noticeable increase in queuing.

Lees Hall Road / Ravensthorpe Road / Forge Lane

8.4.7 Table 8.10 presents the results of the ‘2021 Future Base plus Committed Development plus Cumulative Development’ sensitivity test traffic scenario at the Lees Hall Road / Ravensthorpe Road / Forge Lane mini-roundabout:

**Table 8.10: Lees Hall Road / Ravensthorpe Road / Forge Lane ARCADY – Sensitivity Test Results**

Arm/Movement	2021 Base + Committed				2021 Base + Com + Cumulative Development			
	AM Peak Hour		PM Peak Hour		AM Peak Hour		PM Peak Hour	
	Max RFC	Max Q (PCUs)	Max RFC	Max Q (PCUs)	Max RFC	Max Q (PCUs)	Max RFC	Max Q (PCUs)
Lees Hall Road	0.60	2	0.40	1	0.63	2	0.43	1
Ravensthorpe Road	0.41	1	0.48	1	0.44	1	0.51	1
Forge Lane	0.43	1	0.47	1	0.44	1	0.49	1

RFC = Ratio of Flow to Capacity      Max Q = maximum average queue      PCUs = Passenger Car Units

8.4.8 The results show that the junction will continue to operate within capacity with minimal queuing. It is therefore concluded that this junction can accommodate the proposed cumulative development traffic and additional theoretical background traffic growth.

Forge Lane / Thornhill Road / Station Road

8.4.9 Table 8.11 presents the results of the ‘2021 Future Base plus Committed Development plus Cumulative Development’ sensitivity test traffic scenario at the / Forge Lane / Thornhill Road / Station Road double mini-roundabout. Again, it should be noted that when a junction is shown to be operating over capacity the impacts of marginal changes in traffic flows (i.e. as a result of development generated traffic) will be worse than will occur in practice.

**Table 8.11: Forge Lane / Thornhill Road / Station Road ARCADY Sensitivity Test Results**

Arm/Movement	2021 Base + Committed				2021 Base + Com + Cumulative Development			
	AM Peak Hour		PM Peak Hour		AM Peak Hour		PM Peak Hour	
	Max RFC	Max Q (PCUs)	Max RFC	Max Q (PCUs)	Max RFC	Max Q (PCUs)	Max RFC	Max Q (PCUs)
B6117 Station Road	1.32	127	0.89	6	1.34	139	0.90	7
Forge Lane	1.61	113	0.99	12	1.66	122	1.01	14
Thornhill Road	1.66	82	1.62	206	1.65	84	1.66	222
B6409 Station Road	0.78	4	0.87	6	0.78	4	0.88	6

RFC = Ratio of Flow to Capacity      Max Q = maximum average queue      PCUs = Passenger Car Units

8.4.10 The results show that the addition of the theoretical background traffic growth further worsens the operation of the junction. i-Transport does not consider the future year queues and delays to be realistic. However, the difference between the 'with development' and 'without development' scenarios is not material and it is concluded that the development proposals will not result in a severe impact at the junction.

Huddersfield Road / Calder Road

8.4.11 Table 8.112 presents the results of the '2021 Future Base plus Committed Development plus Cumulative Development' sensitivity test traffic scenario at the Huddersfield Road / Calder Road signal controlled junction:

**Table 8.12: Huddersfield Road / Calder Road Results – Sensitivity Test**

Link	Arm/Movement	2021 Base + Committed				2021 Base + Com + Dev			
		AM Peak Hour		PM Peak Hour		AM Peak Hour		PM Peak Hour	
		DoS (%)	MMQ (PCUs)	DoS (%)	MMQ (PCUs)	DoS (%)	MMQ (PCUs)	DoS (%)	MMQ (PCUs)
2/1	Huddersfield Road (East) - Left	78.9%	18	69.2%	13	80.7%	19	70.9%	14
2/2	Huddersfield Road (East) - Ahead								
3/1	Huddersfield Road (West) - Ahead	58.2%	1	60.0%	8	58.6%	1	60.3%	8
3/2	Huddersfield Road (West) - Right	68.4%	7	65.4%	6	67.5%	7	68.4%	7
4/1	Calder Road	76.3%	9	60.9%	7	80.2%	10	62.2%	7

DoS = Degree of Saturation      MMQ = Mean Maximum Queue      PCUs = Passenger Car Units

8.4.12 The results show that the junction continues to operate within capacity in the sensitivity test scenario, with the cumulative development traffic. The addition of the cumulative development traffic results in minimal increases in queuing at the junction, with the greatest queue increase being a single pcu.

---

**SECTION 9 CONCLUSIONS**

- 9.1 This Transport Assessment has considered the transportation aspects of the proposed residential development at Land off Ravensthorpe Road in the Ravensthorpe area of Dewsbury. The site will deliver up to 120 residential dwellings and a proportion of the units will be affordable.
- 9.2 The adopted Unitary Development Plan allocates the site for housing (as part of allocation H10-5). Kirklees Council is now proposing to allocate a strategic development option, identified within the emerging Local Plan as site H2089 'Land to the South of Ravensthorpe Road, Thornhill Lees, Dewsbury'. The site is therefore considered suitable for housing by Kirklees Council in both the currently adopted UDP and the emerging 'New Local Plan'.
- 9.3 The traffic flows generated by the site will represent a small proportion of the existing traffic in the area. Analysis of the capacity of the adjacent highway network has demonstrated that the trip generation of the proposed residential development will not have a material or severe impact on the operational performance of the surrounding highway network.
- 9.4 The development is proposed to be accessed via the creation of a new priority junction on Ravensthorpe Road. The proposed access has been designed to a feasibility level of detail, cognisant of prevailing design guidance. Suitable crossing facilities are incorporated into the design. Swept path analyses have been undertaken to demonstrate the proposed access can accommodate a Refuse Collection Vehicle and operational assessments demonstrate that the site access junction will operate satisfactorily. The proposed site access arrangements are, therefore, considered fit-for-purpose.
- 9.5 Collision data in the vicinity of the site has been analysed and it is concluded that there is no inherent road safety issue that would preclude the proposed site access, or the development, coming forward.
- 9.6 A range of key facilities and services, including employment, retail, health and education uses, are accessible from the site. Many of these can be accessed locally and are within walking distance of the site. Other key destinations are accessible via bus services operating in the area, or by rail services from Ravensthorpe Station.

9.7 It is therefore concluded that the site is a suitable location for the development proposed, it can be accessed satisfactorily, traffic impacts will not be severe and it is accessible by sustainable modes. There are therefore no overriding highways or transport reasons why planning permission for residential development on the site should not be granted.

## FIGURES

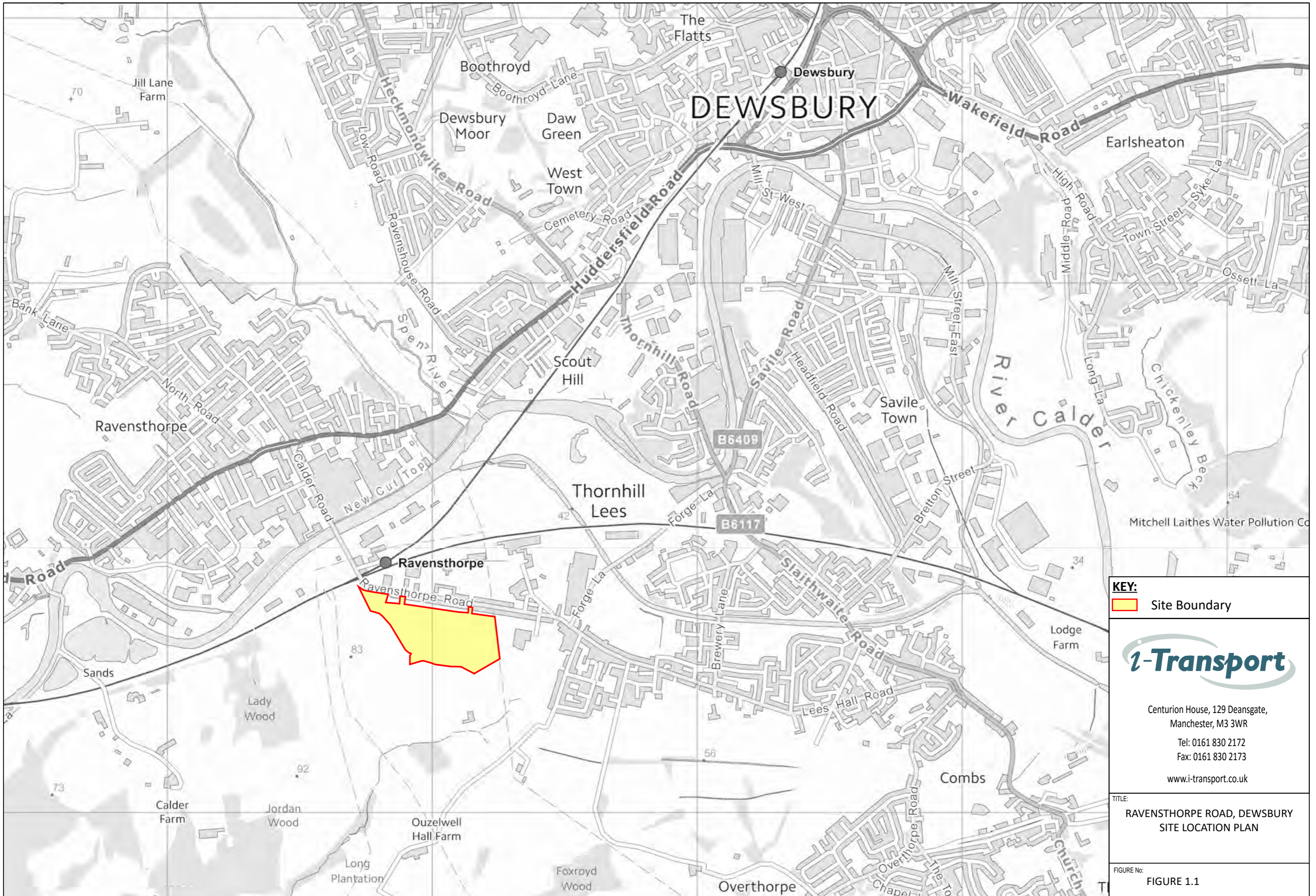

**KEY:**  
 Site Boundary

**i-Transport**

Centurion House, 129 Deansgate,  
 Manchester, M3 3WR  
 Tel: 0161 830 2172  
 Fax: 0161 830 2173  
[www.i-transport.co.uk](http://www.i-transport.co.uk)

TITLE:  
**RAVENSTHORPE ROAD, DEWSBURY  
 SITE LOCATION PLAN**

FIGURE No:  
**FIGURE 1.1**

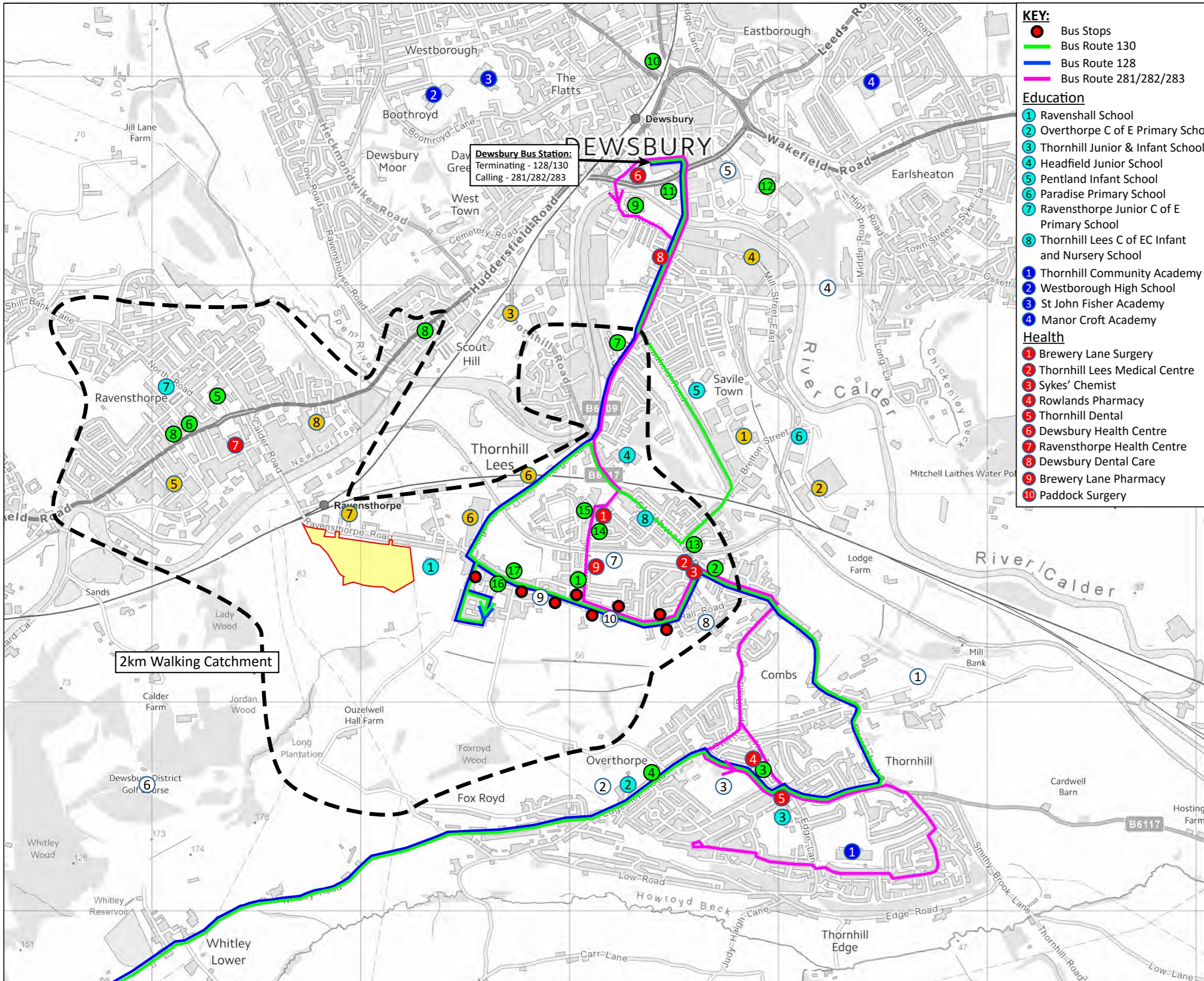

- KEY:**
- Bus Stops
  - Bus Route 130
  - Bus Route 128
  - Bus Route 281/282/283
- Education**
- 1 Ravenshall School
  - 2 Overthorpe C of E Primary School
  - 3 Thornhill Junior & Infant School
  - 4 Headfield Junior School
  - 5 Pentland Infant School
  - 6 Paradise Primary School
  - 7 Ravensthorpe Junior C of E Primary School
  - 8 Thornhill Lees C of EC Infant and Nursery School
  - 9 Thornhill Community Academy
  - 10 Westborough High School
  - 11 St John Fisher Academy
  - 12 Manor Croft Academy
- Health**
- 1 Brewery Lane Surgery
  - 2 Thornhill Lees Medical Centre
  - 3 Sykes' Chemist
  - 4 Rowlands Pharmacy
  - 5 Thornhill Dental
  - 6 Dewsbury Health Centre
  - 7 Ravensthorpe Health Centre
  - 8 Dewsbury Dental Care
  - 9 Brewery Lane Pharmacy
  - 10 Paddock Surgery

- Leisure**
- 1 Thornhill Cricket & Bowling Club
  - 2 Overthorpe Sports Club
  - 3 Overthorpe Park
  - 4 Dewsbury United Cricket Club
  - 5 Dewsbury Sports Centre
  - 6 Dewsbury District Golf Club
  - 7 Thornhill Lees Community Centre
  - 8 Honeysuckle Park
  - 9 Morton House Club & Institute
  - 10 Thornhill Lees Village Hall

- Retail**
- 1 The Bakery
  - 2 Mullaco Supermarket
  - 3 Co-operative Food
  - 4 Edge Top Post Office
  - 5 Ravensthorpe Retail Park
  - 6 Ravensthorpe Post Office
  - 7 Nisa Local
  - 8 Shops on A644
  - 9 Asda
  - 10 Lidl
  - 11 B&Q & Farmfoods
  - 12 Retail Park of Link Road - Sainsburys
  - 13 Shops on B6117
  - 14 Thornhill Lees Post Office
  - 15 Shops on Brewery Lane
  - 16 Kang Brothers Off Licence
  - 17 Arnie's Fish and Chip Shop

- Employment**
- 1 Bretfield Court Industrial Estate
  - 2 Bretton Park Industrial Park
  - 3 Industrial Estates off Thornhill Road
  - 4 Industrial Park off Mill Street East
  - 5 Ravensthorpe & Low Mills Industrial Estate
  - 6 Industrial Estates off Forge Lane
  - 7 Industrial Estates off Ravensthorpe Road
  - 8 Industrial Estate off Huddersfield Road

**i-Transport**

Centurion House, 129 Deansgate,  
Manchester, M3 3WR

Tel: 0161 830 2172  
Fax: 0161 830 2173

[www.i-transport.co.uk](http://www.i-transport.co.uk)

TITLE:  
**RAVENSTHORPE ROAD, DEWSBURY  
KEY FACILITIES PLAN**

FIGURE No:  
**FIGURE 3.1**



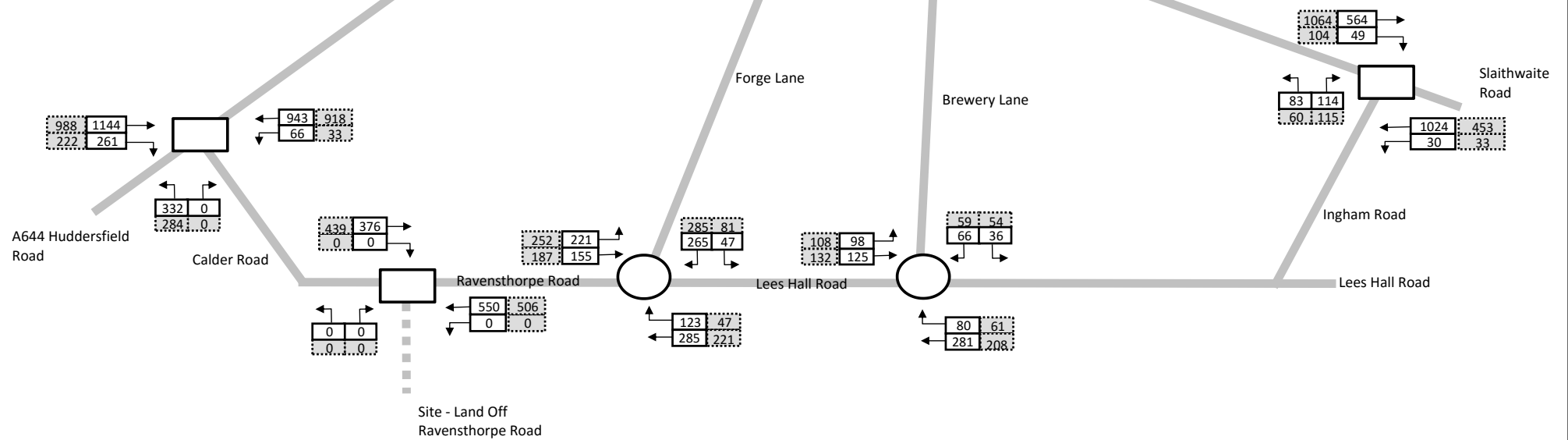
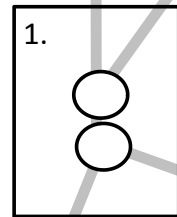
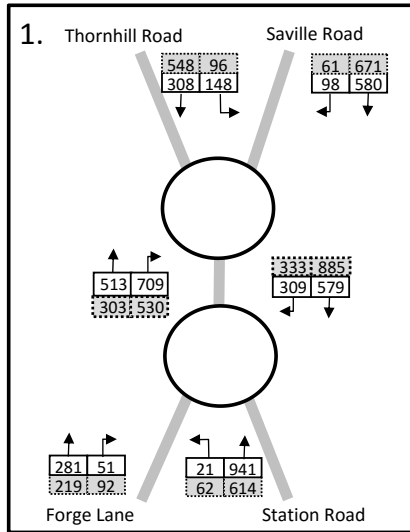

**2016 - 2021 Growth Factors**

AM Peak - 1.0681  
PM Peak - 1.0680

**Key:**

 AM Peak  
 PM Peak

	Park House, Park Square, Leeds LS1 2PW Tel: 0113 3571360 www.i-transport.co.uk
<p align="center">FIGURE 6.1</p>	
<p align="center">Land off Ravensthorpe Road, Dewsbury 2021 Future Year Base</p>	
<p align="right">Note: Traffic flows shown in PCUs</p>	

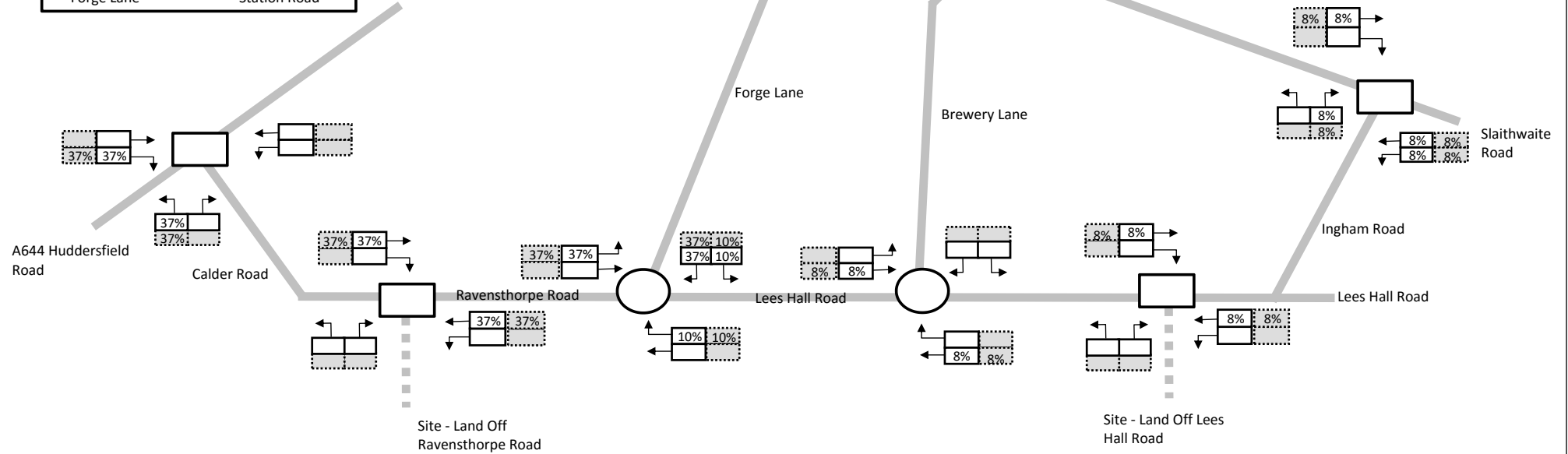
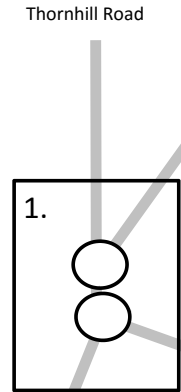
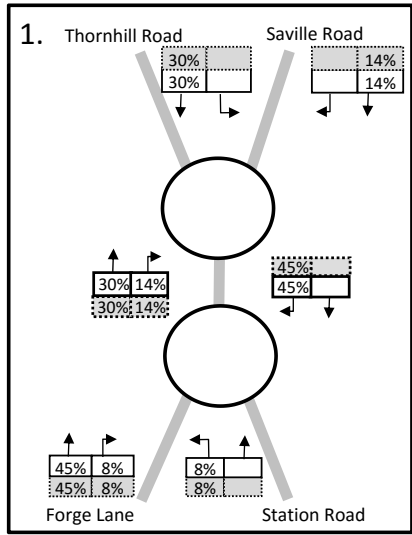

	Park House, Park Square, Leeds LS1 2PW Tel: 0113 3571360 www.i-transport.co.uk
--	---

**FIGURE 6.2**

**Land off Lees Hall Road & Ravensthorpe Road,  
Dewsbury  
Committed Development Distribution**

Note: Traffic flows shown in PCUs

**Key:**

	AM Peak
	PM Peak

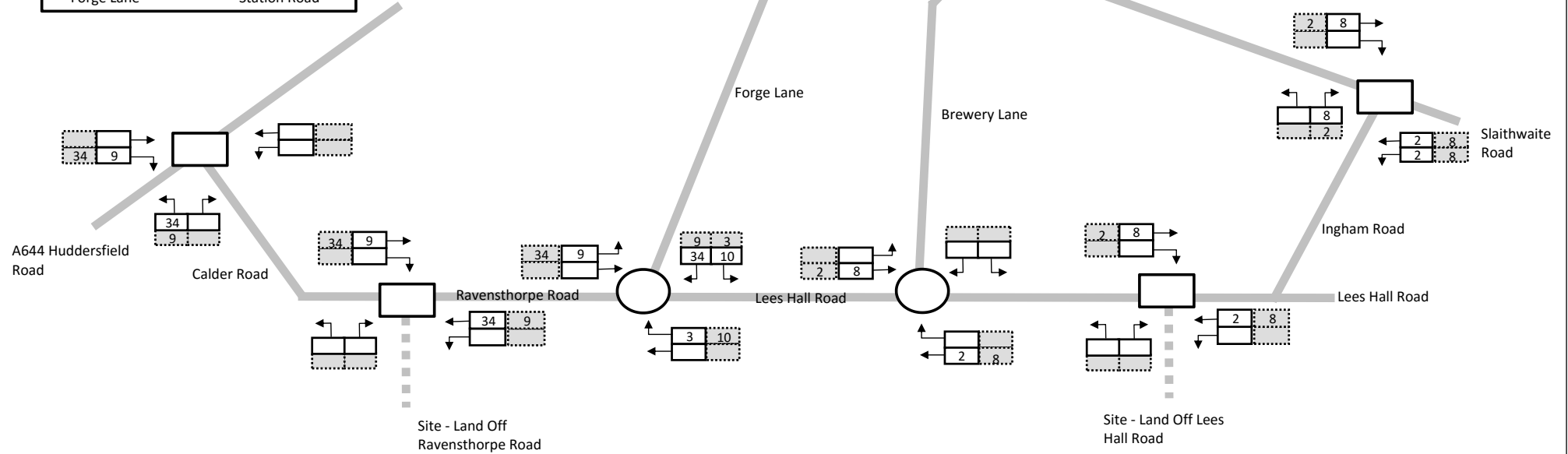
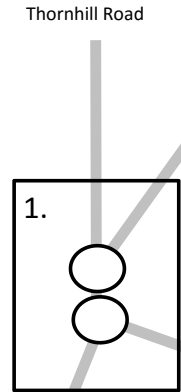
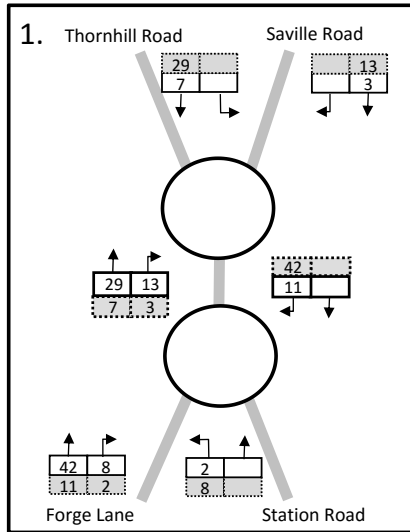

	Park House, Park Square, Leeds LS1 2PW Tel: 0113 3571360 www.1-transport.co.uk
--	---

FIGURE 6.3

Land off Lees Hall Road & Ravensthorpe Road,  
 Dewsbury  
 Committed Development Assignment

**Key:**

	AM Peak
	PM Peak

Note: Traffic flows shown in PCUs



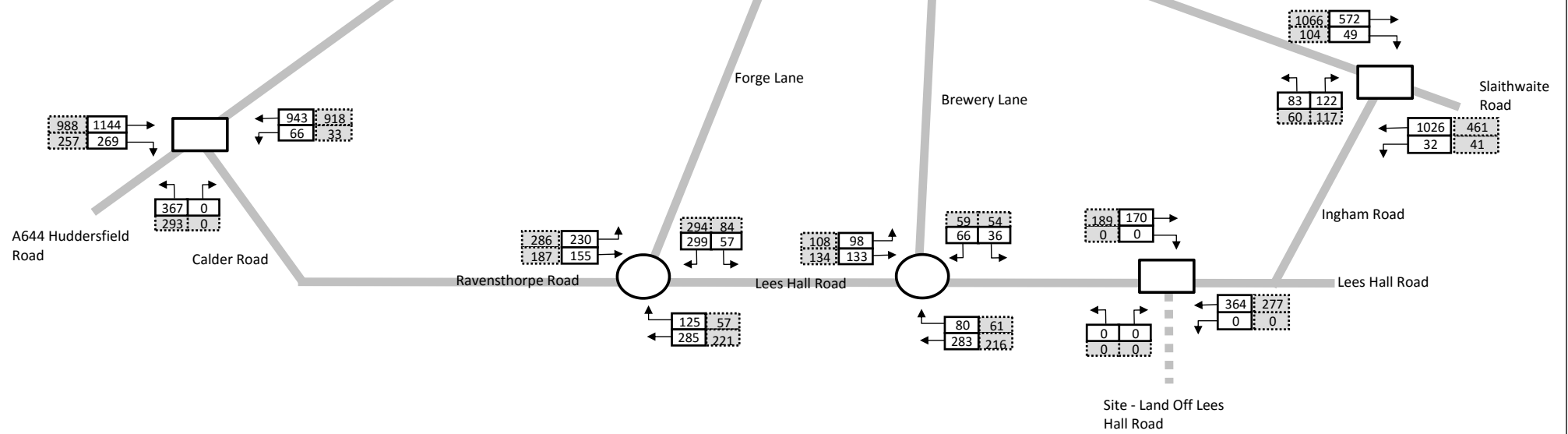
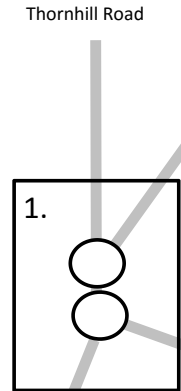
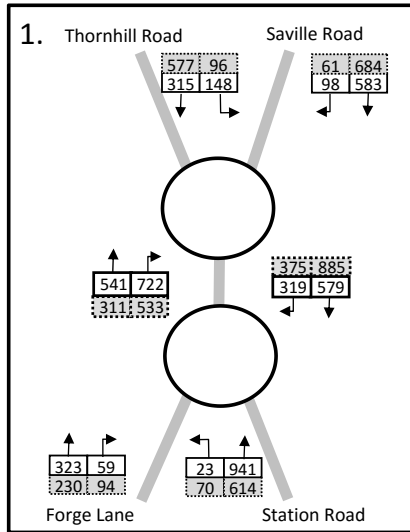

**Key:**

	AM Peak
	PM Peak

	Park House, Park Square, Leeds LS1 2PW Tel: 0113 3573360 www.i-transport.co.uk
--	---

**FIGURE 6.5**

Land off Ravensthorpe Road,  
Dewsbury  
2021 Base + Committed Development

Note: Traffic flows shown in PCUs

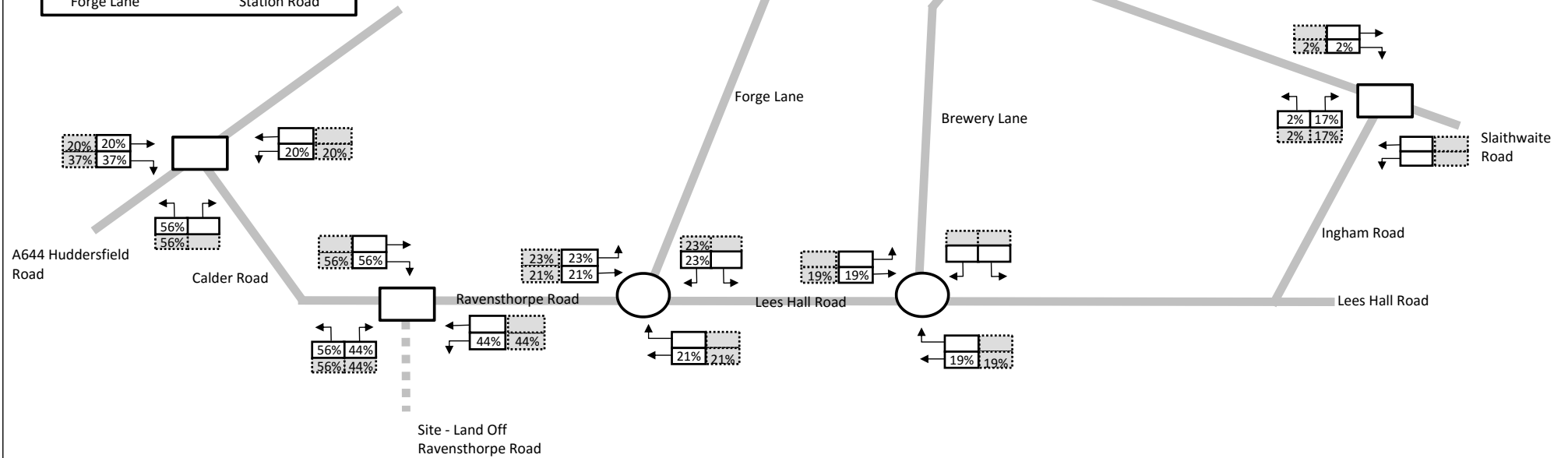
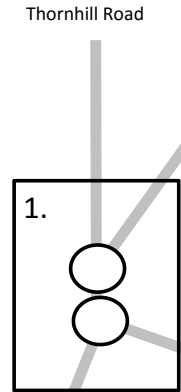
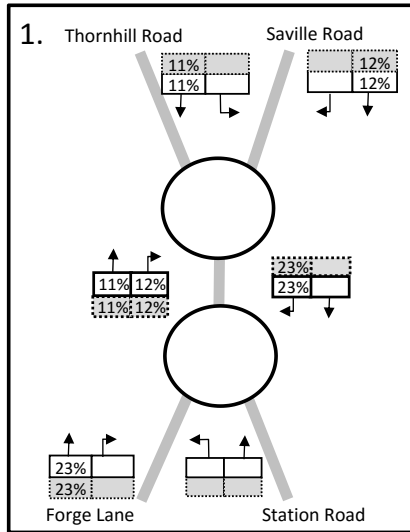

**Key:**

	AM Peak
	PM Peak

	Park House, Park Square, Leeds LS1 2PW Tel: 0113 3571360 www.i-transport.co.uk
--	---

FIGURE 6.6

Land off Ravensthorpe Road,  
Dewsbury  
Development Traffic Distribution

Note: Traffic flows shown in PCUs

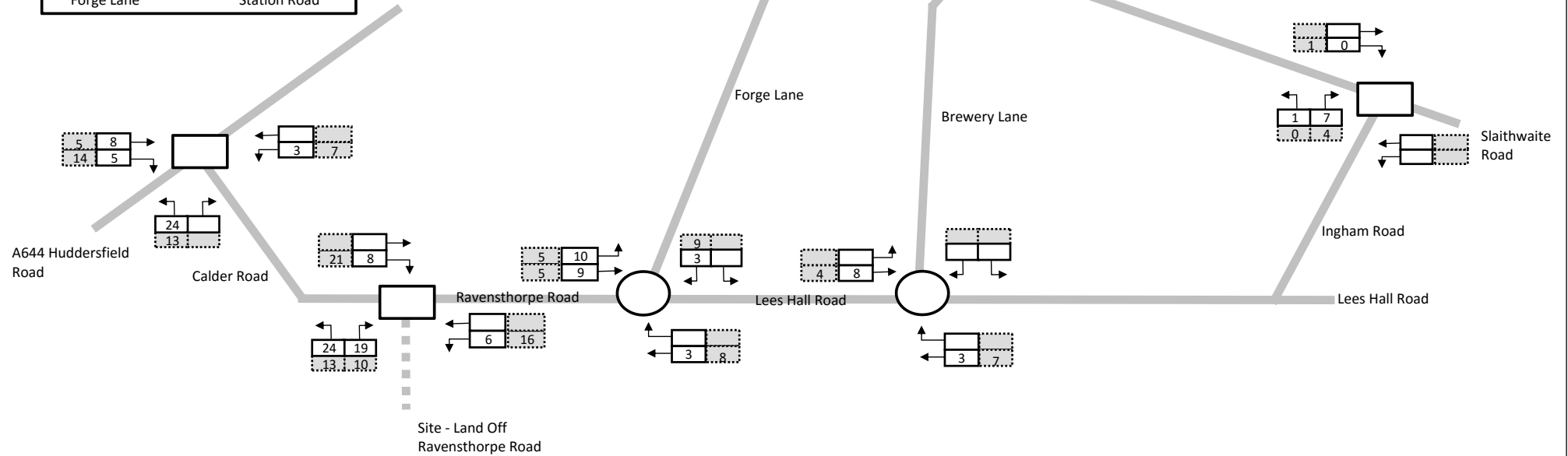
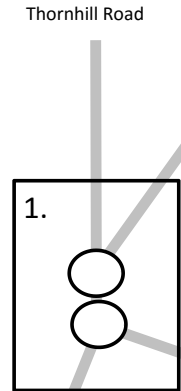
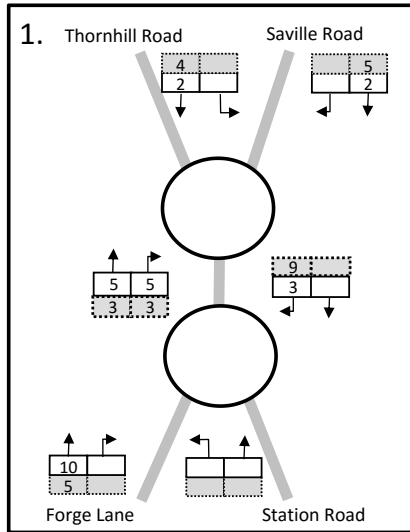

**Key:**

	AM Peak
	PM Peak

	Park House, Park Square, Leeds LS1 2PW Tel: 0113 3571360 www.1-transport.co.uk
--	---

**FIGURE 6.7**

Land off Ravensthorpe Road,  
Dewsbury  
Development Traffic Assignment

Note: Traffic flows shown in PCUs



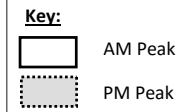
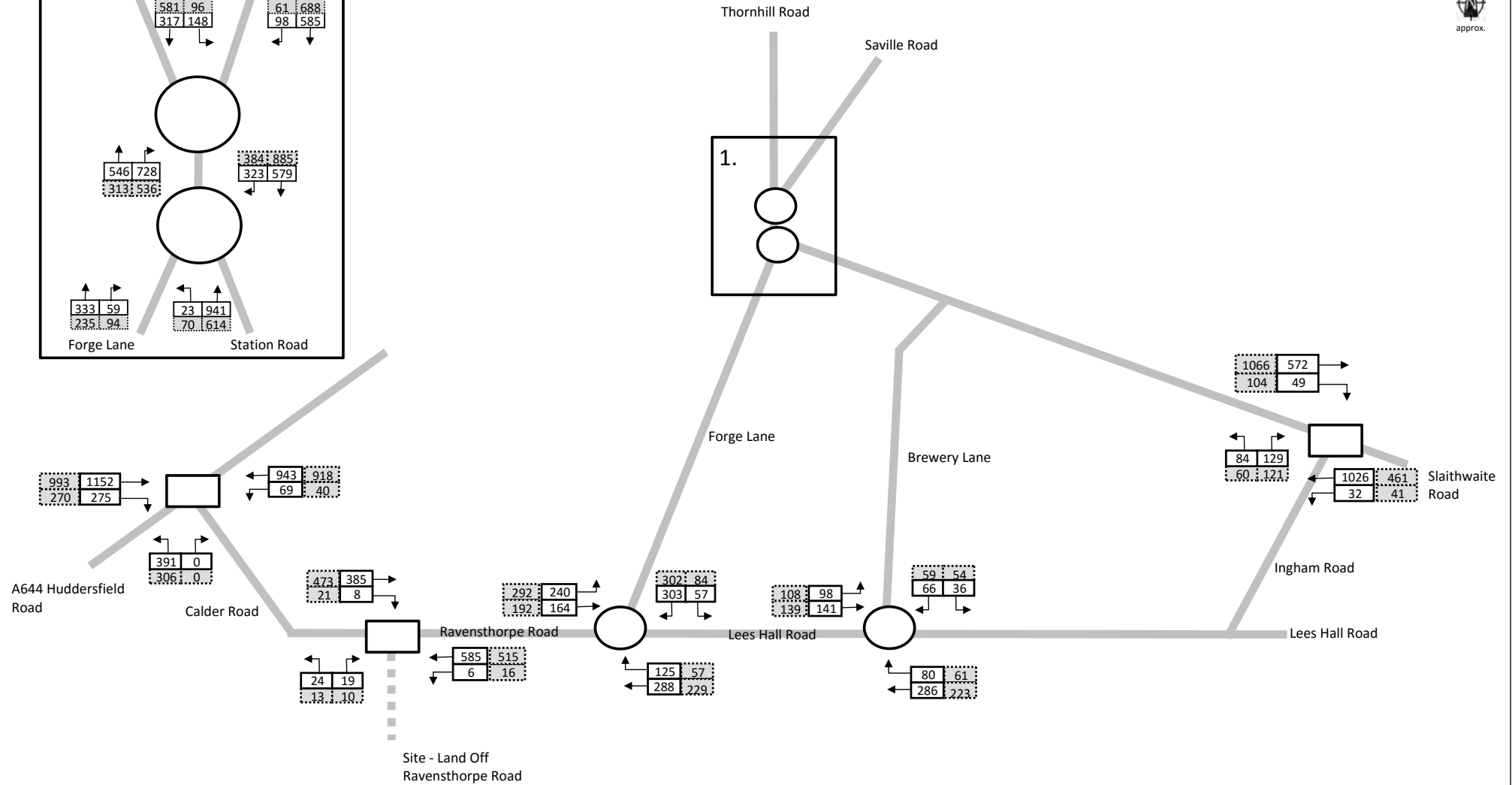
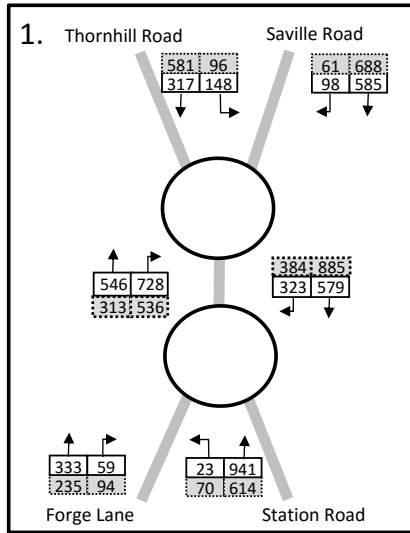

	Park House, Park Square, Leeds LS1 2PW Tel: 0113 3571360 www.i-transport.co.uk
--	---

FIGURE 6.9

Land off Ravensthorpe Road,  
Dewsbury  
2021 Base + Committed + Development

Note: Traffic flows shown in PCUs

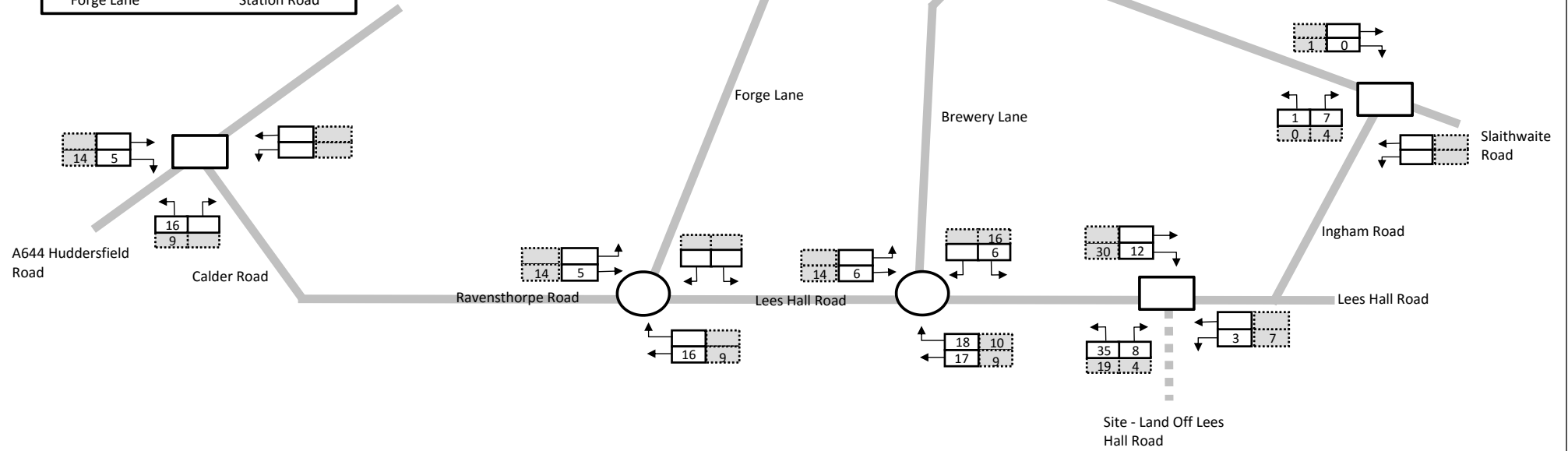
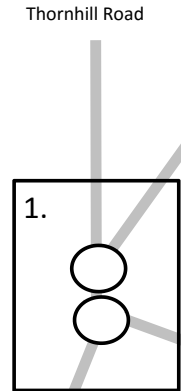
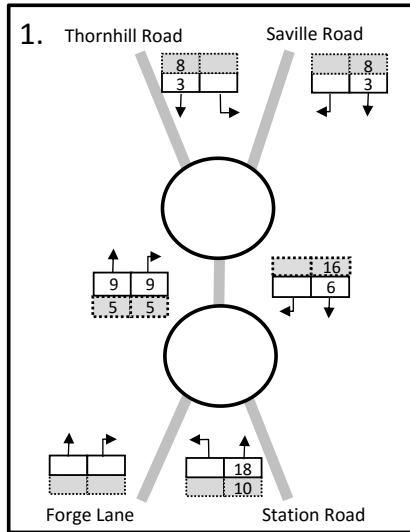

	Park House, Park Square, Leeds LS1 2PW Tel: 0113 3571360 www.1-transport.co.uk
--	---

FIGURE 8.1

Land off Lees Hall Road,  
 Dewsbury  
 Development Traffic Assignment

**Key:**

	AM Peak
	PM Peak

Note: Traffic flows shown in PCUs

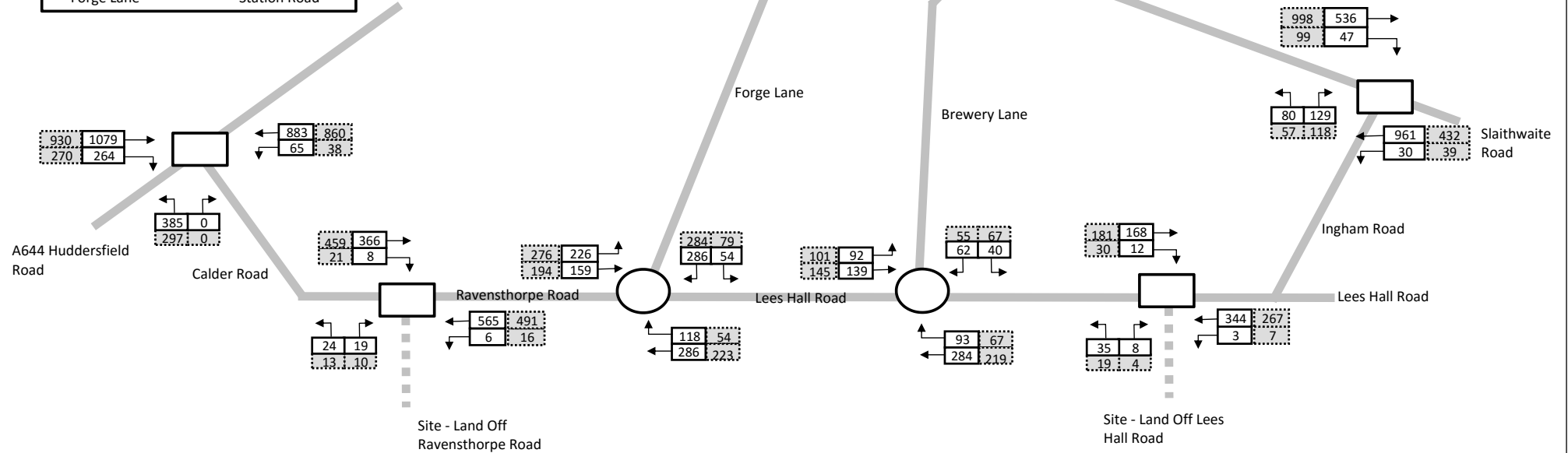
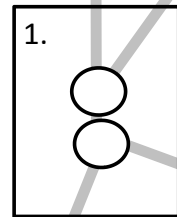
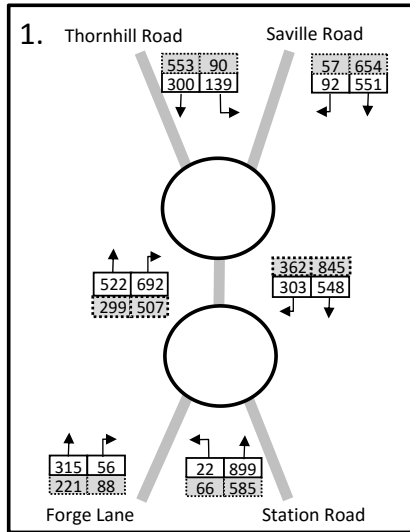

	Park House, Park Square, Leeds LS1 2PW Tel: 0113 3571360 www.i-transport.co.uk
--	---

FIGURE 8.2

Land off Lees Hall Road & Ravensthorpe Road,  
 Dewsbury  
 Base + Committed + Cumulative Development

**Key:**

	AM Peak
	PM Peak

Note: Traffic flows shown in PCUs

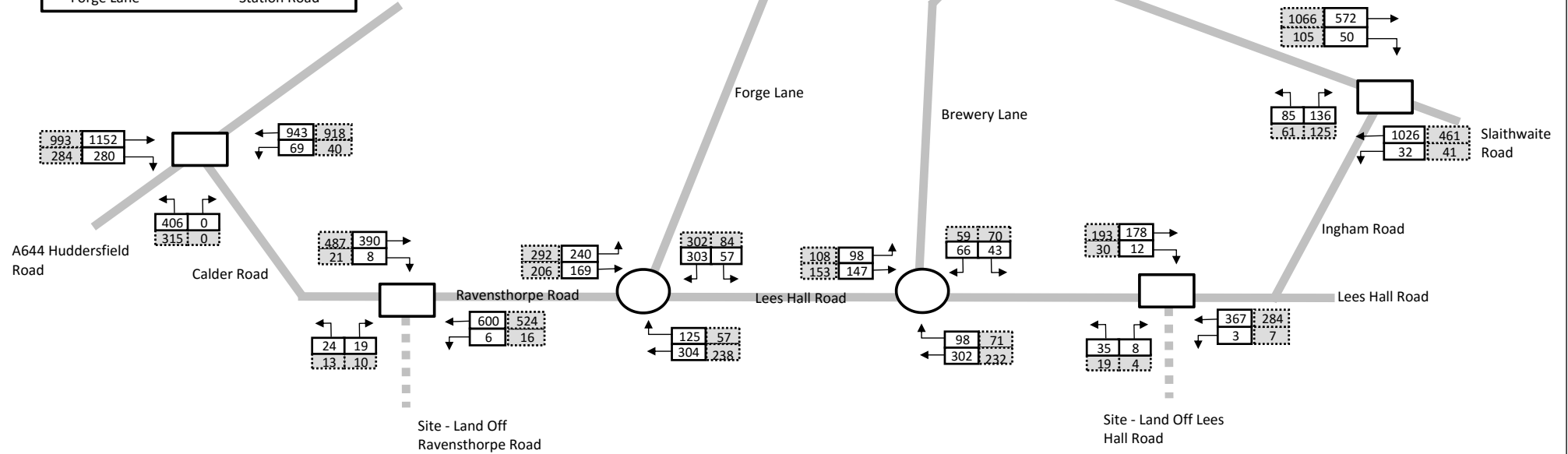
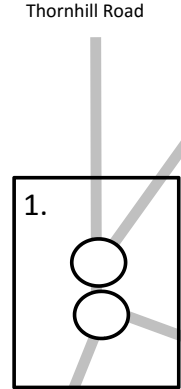
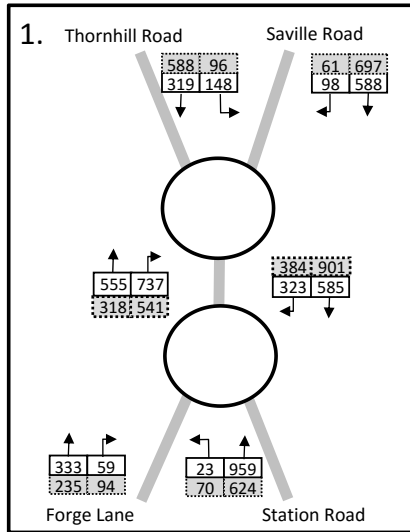

**Key:**

	AM Peak
	PM Peak

	Park House, Park Square, Leeds LS1 2PW Tel: 0113 3571360 www.i-transport.co.uk
--	---

**FIGURE 8.3**

Land off Lees Hall Road & Ravensthorpe Road,  
Dewsbury  
2021 Base + Committed + Cumulative Development

Note: Traffic flows shown in PCUs